

# Air conditioner

---

## Installation manual

AC\*\*\*BNJPKG

---

- Thank you for purchasing this Samsung air conditioner.
- Before operating this unit, please read this Installation manual carefully and retain it for future reference.



**SAMSUNG**

# Contents

---

<b>Safety Information</b>	<b>3</b>
Safety Information	3
<b>Installation Procedure</b>	<b>6</b>
Installation Procedure	6
Step 1 Checking and preparing accessories	6
Step 2 Choosing the installation location	6
Step 3 Installing the indoor unit	9
Step 4 Purging inert gas from the indoor unit	10
Step 5 Connecting the assembly pipes to the refrigerant pipes	10
Step 6 Cutting and flaring the pipes	11
Step 7 Performing the gas leak test	12
Step 8 Insulating the refrigerant pipes	12
Step 9 Installing the drain hose and drain pipe	13
Step 10 Optional : Half concealed Installation	14
Step 11 Connecting the power and communication cables	14
Step 12 Optional: Extending the power cable	15
Step 13 Optional : Setting the Emergency Temperature Output (ETO) function	17
Step 14 Optional : Connecting the External control (MIM-B14), Wired Remote Control and External Floating switch	19
Step 15 Setting indoor unit addresses and installation options	20
<b>Appendix</b>	<b>28</b>
Troubleshooting	28

# Safety Information

## **WARNING: Read This Manual**

- Read and follow all safety information and instructions before installation, use, or maintenance of this appliance. Incorrect installation, use, or maintenance of this appliance can result in death, serious injury, or property damage. Keep these instructions with this appliance. This manual is subject to change. For the latest version, visit [www.samsung.com](http://www.samsung.com).

## Notices and notes

To make you aware of safety messages and highlighted information, we use the following notices and notes throughout this manual:

### **WARNING**

Hazards or unsafe practices that may result in severe personal injury or death.

### **CAUTION**

Hazards or unsafe practices that may result in minor personal injury or property damage.

### **IMPORTANT**

Information of special interest

### **NOTE**

Supplementary information that may be useful



**WARNING: Low burning velocity material**  
(This appliance is filled with R-32.)



The user and installer guides should be read carefully.



The user and installer guides should be read carefully.



The service guide should be read carefully.

### **WARNING**

The installation and testing of this appliance must be performed by a qualified technician.

- The instructions in this manual are not intended as a substitute for proper training or adequate experience in the safe installation of the appliance.

Always install the air conditioner in compliance with current local, state, and federal safety standards.

# Safety Information

## General information

### WARNING

- Carefully read the content of this manual before installing the air conditioner and store the manual in a safe place in order to be able to use it as reference after installation.
- For maximum safety, installers should always carefully read the following warnings.
- Store the operation and installation manual in a safe location and remember to hand it over to the new owner if the air conditioner is sold or transferred.
- This manual explains how to install an indoor unit with a split system with two SAMSUNG units. The use of other types of units with different control systems may damage the units and invalidate the warranty. The manufacturer shall not be responsible for damages arising from the use of non compliant units.
- The manufacturer shall not be responsible for damage originating from unauthorized changes or the improper connection of electric and requirements set forth in the "Operating Limits" table, included in the manual, shall immediately invalidate the warranty.
- The air conditioner should be used only for the applications for which it has been designed: the indoor unit is not suitable to be installed in areas used for laundry.
- Do not use the units if damaged. If problems occur, switch the unit off and disconnect it from the power supply.
- In order to prevent electric shocks, fires or injuries, always stop the unit, disable the protection switch and contact SAMSUNG's technical support if the unit produces smoke, if the power cable is hot or damaged or if the unit is very noisy.
- Always remember to inspect the unit, electric connections, refrigerant tubes and protections regularly. These operations should be performed by qualified personnel only.
- The unit contains moving parts, which should always be kept out of the reach of children.
- Do not attempt to repair, move, alter or reinstall the unit. If performed by unauthorized personnel, these operations may cause electric shocks or fires.
- Do not place containers with liquids or other objects on the unit.

- All the materials used for the manufacture and packaging of the air conditioner are recyclable.
- The packing material and exhaust batteries of the remote controller(optional) must be disposed of in accordance with current laws.
- The air conditioner contains a refrigerant that has to be disposed of as special waste. At the end of its life cycle, the air conditioner must be disposed of in authorised centres or returned to the retailer so that it can be disposed of correctly and safely.
- Wear protective equipment (such as safety gloves, goggles, and headgear) during installation and maintenance works. Installation/repair technicians may be injured if protective equipment is not properly equipped.
- Do not use means to accelerate the defrost operation or to clean, other than those recommended by Samsung.
- Do not pierce or burn.
- Be aware that refrigerants may not contain an odour.

## Installing the unit

### WARNING

**IMPORTANT: When installing the unit, always remember to connect first the refrigerant tubes, then the electrical lines.**

- Always disassemble the electric lines before the refrigerant tubes.
- Upon receipt, inspect the product to verify that it has not been damaged during transport. If the product appears damaged, DO NOT INSTALL it and immediately report the damage to the carrier or retailer (if the installer or the authorized technician has collected the material from the retailer.)
- After completing the installation, always carry out a functional test and provide the instructions on how to operate the air conditioner to the user.
- Do not use the air conditioner in environments with hazardous substances or close to equipment that release free flames to avoid the occurrence of fires, explosions or injuries.
- Do not install the product in a place where thermohygrostat is needed (such as server room, machinery room, computer room, etc.) Those places do not provide guaranteed operation condition of the product therefore performance can be poor in these places.



- Do not install the product in a ship or a vehicle (such as a campervan). Salt, vibration or other environmental factor may cause the product malfunction, electric shock or fire.
- Our units should be installed in compliance with the spaces shown in the installation manual, to ensure accessibility from both sides and allow repairs or maintenance operations to be carried out. The unit's components should be accessible and easy to disassemble without endangering people and objects. For this reason, when provisions of the installation manual are not complied with, the cost required to access and repair the units (in SAFETY CONDITIONS, as set out in prevailing regulations) with harnesses, ladders, scaffolding or any other elevation system will NOT be considered part of the warranty and will be charged to the end customer.
- Auxiliary devices which may be a potential ignition source shall not be installed in the duct work.
- Be sure not to perform power cable modification, extension wiring, and multiple wire connection.
  - It may cause electric shock or fire due to poor connection, poor insulation, or current limit override.
  - When extension wiring is required due to power line damage, refer to "**Step 12 Optional: Extending the power cable**" in the installation manual.

## CAUTION

**Make sure that you earth the cables.**

- Do not connect the earth wire to the gas pipe, water pipe, lighting rod or telephone wire. If earthing is not complete, electric shock or fire may occur.

**Install the circuit breaker.**

- If the circuit breaker is not installed, electric shock or fire may occur.

**Make sure that the condensed water dripping from the drain hose runs out properly and safely.**

**Install the power cable and communication cable of the indoor and outdoor unit at least 1m away from the electric appliance.**

**Install the indoor unit away from lighting apparatus using the ballast.**

- If you use the wireless remote control, reception error may occur due to the ballast of the lighting apparatus.

**Do not use the indoor unit for preservation of food items, plants, equipment, and art works. This may cause deterioration of their quality.**

**Do not install the indoor unit if it has any drainage problem.**

## Power supply line, fuse or circuit breaker







### WARNING

- Always make sure that the power supply is compliant with current safety standards. Always install the air conditioner in compliance with current local safety standards.
- Always verify that a suitable grounding connection is available.
- Verify that the voltage and frequency of the power supply comply with the specifications and that the installed power is sufficient to ensure the operation of any other domestic appliance connected to the same electric lines.
- Always verify that the cut-off and protection switches are suitably dimensioned.
- Verify that the air conditioner is connected to the power supply in accordance with the instructions provided in the wiring diagram included in the manual.
- Always verify that electric connections (cable entry, section of leads, protections...) are compliant with the electric specifications and with the instructions provided in the wiring scheme. Always verify that all connections comply with the standards applicable to the installation of air conditioners.
- Devices disconnected from the power supply should be completely disconnected in the condition of overvoltage category.

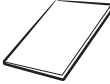
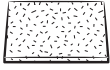
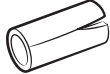
# Installation Procedure

## Step 1 Checking and preparing accessories

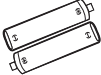
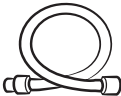
The following accessories are supplied with the indoor unit. The type and quantity may differ, depending on the specifications.

User manual (1) 	Installation manual (1) 
Insulation Install Outlet (1) 	Insulation Install SVC (1) 
Bracket Hanger (1) 	Cable-tie (8) 
Wireless remote control (1) 	Battery (2) 
Drain Hose (1) 	M4x16 tapped screw(2) 
Remote Control Holder (1) 	

## Step 2 Choosing the installation location

### Installation location requirements

- There must be no obstacles near the air inlet and outlet.
- Install the indoor unit on a ceiling that can support its weight.
- Maintain sufficient clearance around the indoor unit.
- Before installing the indoor unit, be sure to check whether the chosen location is well-drained.
- The indoor unit must be installed such that it is beyond public access and is not touchable by users.
- Rigid wall without vibration.
- Where it is not exposed to direct sunshine.
- Where the air filter can be removed and cleaned easily.

### WARNING

- If appliances contain R-32 refrigerant, then the floor area of the room in which the appliances are installed, operated and stored must be larger than the minimum floor area defined in table below A (m<sup>2</sup>).

Minimum required room area (A, m <sup>2</sup> )	
m (kg)	Ceiling-mounted type
≤ 1.842	No requirement
1.843	3.64
1.9	3.75
2.0	3.95
2.2	4.34
2.4	4.74
2.6	5.13
2.8	5.53
3.0	5.92
3.2	6.48
3.4	7.32
3.6	8.20
3.8	9.14
4.0	10.1

4,2	11,2
4,4	12,3
4,6	13,4
4,8	14,6
5,0	15,8
5,2	17,1
5,4	18,6
5,6	20,0
5,8	21,5
6,0	23,0

- m : Total refrigerant charge in the system
- A : Minimum required room area
- IMPORTANT: it's mandatory to consider either the table 1 or taking into consideration the local law regarding the minimum living space of the premises.
- Minimum installation height of indoor unit is 0,6 m for floor mounted, 1,8 m for wall, 2,2 m for ceiling.

### Do not install the air conditioner in following places.

- Place where there is mineral oil or arsenic acid. Resin parts flame and the accessories may drop or water may leak. The capacity of the heat exchanger may reduce or the air conditioner may be out of order.
- A place with aromatic diffusers, aromatherapy, scented candles or perfumes as the chemicals may react to the product's materials and may result in system failure or refrigerant leaks.
- The place where corrosive gas such as sulphuric acid gas generates from the vent pipe or air outlet.
- The copper pipe or connection pipe may corrode and refrigerant may leak.
- The place where there is a machine that generates electromagnetic waves. The air conditioner may not operate normally due to control system.
- The place where there is a danger of existing combustible gas, carbon fibre or flammable dust.
- The place where thinner or gasoline is handled. Gas may leak and it may cause fire.

### Indoor unit installation requirement

- This unit has to be installed as floor type only.
- There must be no obstacles near the air inlet and outlet.
- Select a convenient location that permits the air to reach every corner of the area to be cooled.
- Pre-plan for easy and short routing of the refrigerant tubing and wiring to the outdoor unit.
- There should be no flammable gas, alkaline, substances present in the air.
- Maintain sufficient clearance around the indoor unit.
- Make sure that the water dripping from the drain hose runs away correctly and safely.
- Do not install the unit where it will be exposed to direct sunlight.

### CAUTION

- Our units should be installed in compliance with the spaces shown in the installation manual, to ensure accessibility from both sides and allow repairs or maintenance operations to be carried out. The unit's components should be accessible and easy to disassemble without endangering people and objects.
- For this reason, when provisions of the installation manual are not complied with, the cost required to access and repair the units (in SAFETY CONDITIONS, as set out in prevailing regulations) with harnesses, ladders, scaffolding or any other elevation system will NOT be considered part of the warranty and will be charged to the end customer.

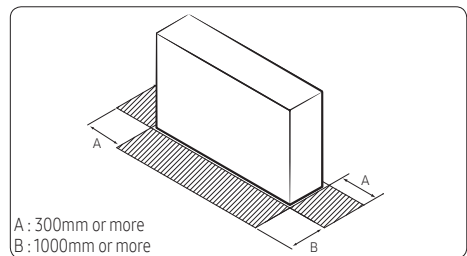

# Installation Procedure

## Indoor unit dimensions

AC026BNJPKG,AC035BNJPKG

(Unit: mm)

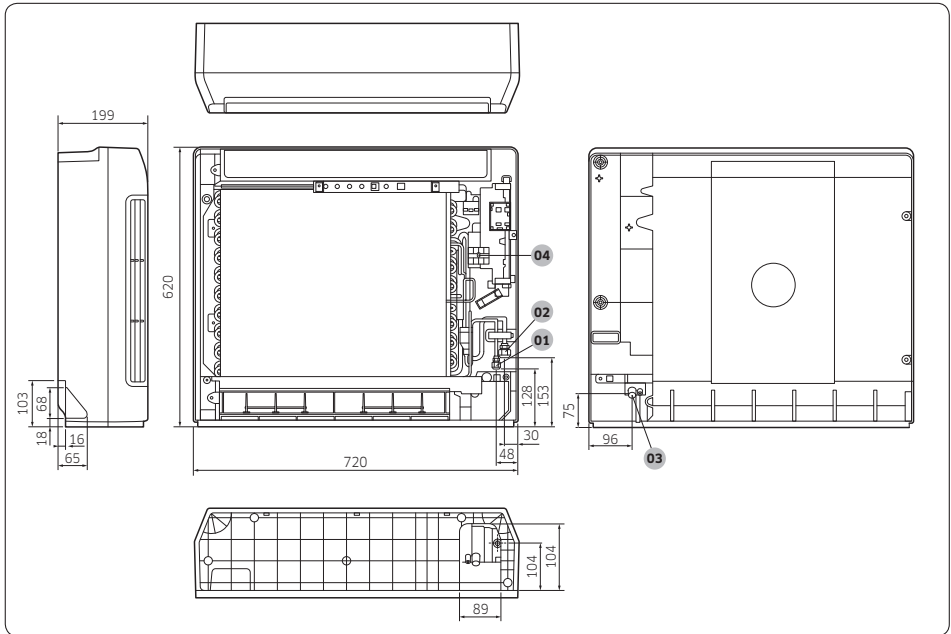

No.	Name	Description
01	Liquid pipe connection	Ø6.35 (1/4")
02	Gas pipe connection	Ø9.52 (3/8")
03	Drainpipe connection	ID : Ø12 ; OD : Ø18
04	Power supply connection	0.75~1.5mm <sup>2</sup> , 3wires

- Length of pipes and difference in height: see the outdoor unit installation manual
- Vacuum and refrigerant charge: see the outdoor unit installation manual

### Step 3 Installing the unit

- 1 When you install the indoor with side-pipe connection, please make space more than 300mm from the wall.

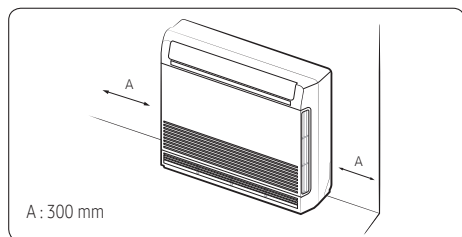

- 2 When you install the indoor at the inclined floor, please lean the set toward the drain hose and pipe connection to prevent water overflowing.

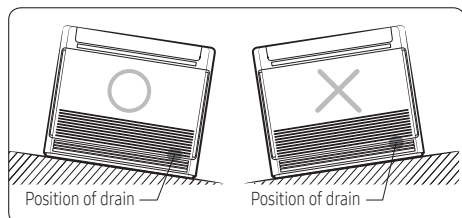

- 3 Please remove packaging materials when installing the unit. (\*\*026/35\*\*\*\*\*: 6 Items / \*\*052\*\*\*\*\*: 7 Items)

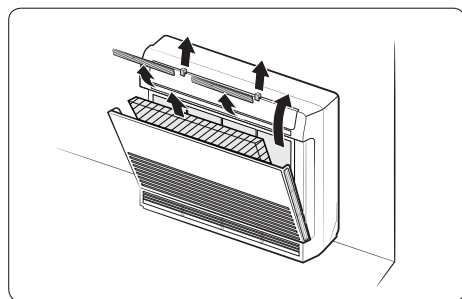

- 4 The body front should be opened to connect pipes. Remove the 4 screws on the front of the unit and then pull the lower section of the unit out as shown below.

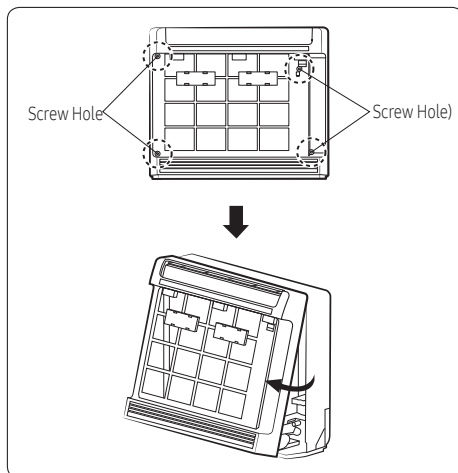

- 5 Make a hole in the wall.

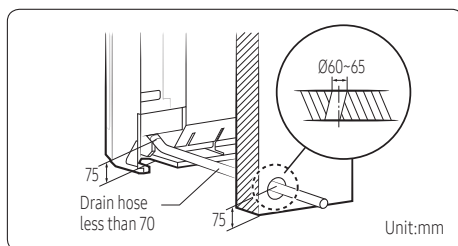

- 6 Refrigerant and drain pipes and cables should go through the hole located at the on the back of the unit at the bottom.

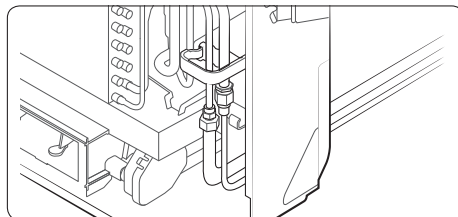

# Installation Procedure

7 Hanging the indoor unit on the Bracket Hanger, then fix the Indoor Unit by using 4 Screws.

- Case 1. Installing on the floor: You must secure the unit to the wall using 4 screws to ensure that the unit does not fall.
- Case 2. Hanging on the wall : Follow the installation guide supplied in the accessory part.
  - Screw positions are specified on the installation guide.

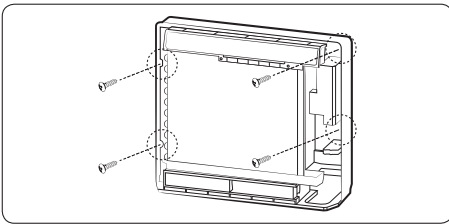

## Step 4 Purging inert gas from the indoor unit

From factory the unit is supplied and set with a pre-charge of nitrogen gas (inert gas). Therefore, all inert gas must be purged before connecting the assembly piping.

Unscrew the pinch pipe at the end of each refrigerant pipe.

- Result: All inert gas escapes from the indoor unit.

### NOTE

To prevent dirt or foreign objects from getting into the pipes during installation, do NOT remove the pinch pipe completely until you are ready to connect the piping.

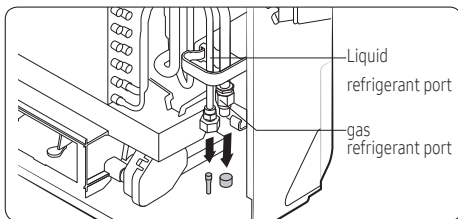

The designs and shape are subject to change according to the model.

## Step 5 Connecting the assembly pipes to the refrigerant pipes

There are two refrigerant pipes of different diameters :

- A smaller one for the liquid refrigerant.
- A larger one for the gas refrigerant. The inside of copper pipe must be clean and has no dust.

1 Remove the pinch pipes and connect the assembly pipes. First tighten the flare nuts manually and then with a torque wrench and a spanner applying the following torque.

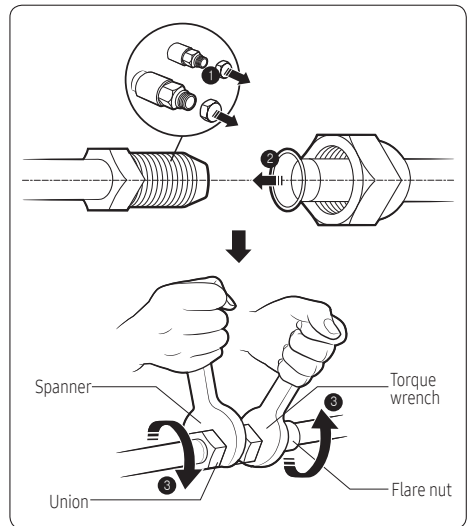

Outer Diameter	Torque
mm	N•m
Ø6.35	14 to 18
Ø9.52	34 to 42
Ø12.70	49 to 61
Ø15.88	68 to 82
Ø19.05	100 to 120

(1 N•m=10 kgf•cm)

### NOTE

If the pipes must be shortened, see **Step 6 Cutting and flaring the pipes** on page 11.

- 2 Use insulation that is thick enough to cover the refrigerant pipe to prevent condensate water on the outside of pipe and to ensure system efficiency. Condensation can drip onto the floor causing property damage or a slip hazard.
- 3 Cut off any excess foam insulation.
- 4 Make sure that the bent sections of pipe are not kinked or cracked.
- 5 It is necessary to double the insulation thickness (0.39 inch or more, 10 mm or more) to prevent condensation even on the insulator when if the installed area is warm and humid.
- 6 Do not use joints or extensions for the pipes that connect the indoor and outdoor unit.

**CAUTION**

- Connect the indoor and outdoor units using pipes with flared connections (not supplied). For the lines, use insulated, unwelded, degreased and deoxidized copper pipe (Cu DHP type to ISO 1337 or UNI EN 12735-1), suitable for operating pressures of at least 4200kPa and for a burst pressure of at least 20700kPa. Copper pipe for hydro-sanitary applications is completely unsuitable.
- For sizing and limits (height difference, line length, max. bends, refrigerant charge, etc.) see the outdoor unit installation manual.
- All refrigerant connection must be accessible, in order to permit either unit maintenance or removing it completely.

**Step 6 Cutting and flaring the pipes**

- 1 Make sure that you have the required tools available. (pipe cutter, reamer, flaring tool and pipe holder)
- 2 If you wish to shorten the pipes, cut it with a pipe cutter, taking care to ensure that the cut edge remains at a 90° angle with the side of the pipe. Refer to the illustrations below for examples of edges cut correctly and incorrectly.

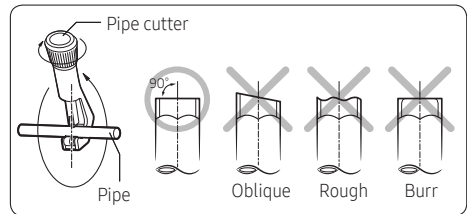

- 3 To prevent any gas from leaking out, remove all burrs at the cut edge of the pipe, using a reamer.
- 4 Slide a flare nut on to the pipe and modify the flare.

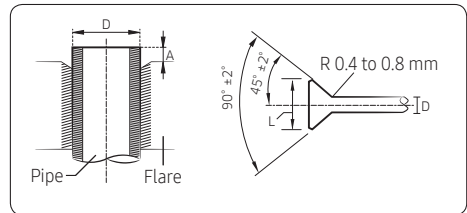

Outer Diameter (D)	Depth (A)	Flare dimension (L)
Ø6.35 mm	1.3 mm	8.7~9.1 mm
Ø9.52 mm	1.8 mm	12.8~13.2 mm
Ø12.70 mm	2.0 mm	16.2~16.6 mm
Ø15.88 mm	2.2 mm	19.3~19.7 mm
Ø19.05 mm	2.2 mm	23.6~24.0 mm



# Installation Procedure

- 5 Check that the flaring is correct, referring to the illustrations below for examples of incorrect flaring.

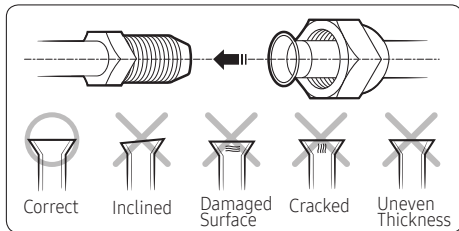

## ⚠ CAUTION

- If the pipes require brazing ensure that OFN (Oxygen Free Nitrogen) is flowing through the system.
- Nitrogen blowing pressure range is 0.02 - 0.05MPa.

## Step 7 Performing the gas leak test

To identify potential gas leaks on the indoor unit, inspect the connection area of each refrigerant pipe using a leak detector for R-32.

Before recreating the vacuum and recirculating the refrigerant gas, pressurize the whole system with nitrogen (using a cylinder with a pressure reducer) at a pressure above 4 MPa in order to immediately detect leaks on the refrigerant fittings.

Made vacuum for 15 minutes and pressurizing system with nitrogen.

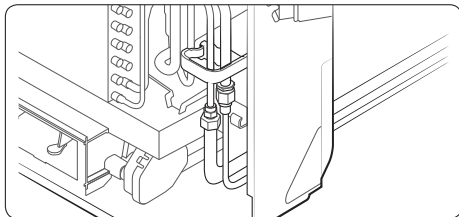

## ⚠ CAUTION

- If the pipes require brazing ensure that OFN (Oxygen Free Nitrogen) is flowing through the system.

## Step 8 Insulating the refrigerant pipes

Once you have checked that there are no leaks in the system, you can insulate the piping and hose.

- 1 To avoid condensation problems, place Acrylonitrile Butadien Rubber separately around each refrigerant pipe.

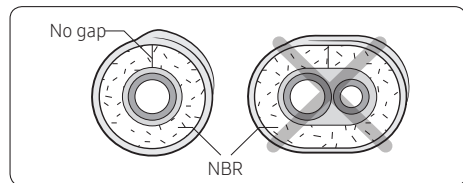

## 📄 NOTE

- Always make the seam of pipes face upwards.

## ⚠ CAUTION

- The insulation has to be produced in full compliance of European regulation reg. EEC / EU 2037/ 2000 that requires the use of sheaths insulation form without using CFC and HCFC gases for health and the environment.
- 2 Wind insulating tape around the pipes and drain hose avoiding compressing the insulation too much.

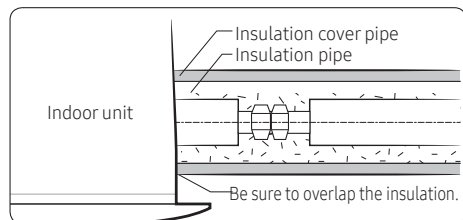

## ⚠ CAUTION

- Be sure to wrap insulation tightly without any gaps.
- 3 Finish wrapping insulating tape around the rest of the pipes leading to the outdoor unit.
- 4 The pipes and electrical cables connecting the indoor unit with the outdoor unit must be fixed to the wall with suitable ducts.

## ⚠ CAUTION

- Make sure that all refrigerant connection must be accessible for easy maintenance and detachment.

- 5 Select the insulation of the refrigerant pipe.
- Insulate the gas side and liquid side pipe, noting the insulation thickness that must differ according to the pipe size.
  - Standard: Less than an indoor temperature of 30°C, with humidity at 85%. If installing in a high humidity environment, use one grade thicker insulator by referring to the table below. If installing in an unfavourable environment, use thicker one.
  - The heat-resistance temperature of the insulator must be more than 120°C.

Pipe	Pipe size	Insulation type (heating/cooling)		Remarks
		Standard (Less than 30°C, 85%)	High humidity (Over 30°C, 85%)	
		EPDM, NBR		
Liquid pipe	Ø6.35 to Ø9.52	9t	9t	The internal temperature is higher than 120°C.
	Ø12.7 to Ø19.05	13t	13t	
Gas pipe	Ø6.35	13t	19t	
	Ø9.52	19t	25t	
	Ø12.70			
	Ø15.88			
Ø19.05				

- When installing insulation in the places and conditions below, use the same insulation that is used for high humidity conditions.

<Geological condition>
High humidity locations such as shorelines, hot springs, lake or riversides, and ridges (when part of the building is covered by earth and sand)
<Operation purpose condition>
Restaurant ceiling, sauna, swimming pool etc.
<Building construction condition>
Ceilings frequently exposed to moisture and cooling are not covered. For example, pipes installed at a corridor of a dormitory and studio or near an exit that opens and closes frequently. Places (where the pipes are installed) that are highly humid due to a lack of ventilation.

## Step 9 Installing the drain hose and drain pipe

When installing the drain hose for the indoor unit, check if condensation draining is adequate. When passing the drain hose through the 65mm hole drilled in the wall, check the following:

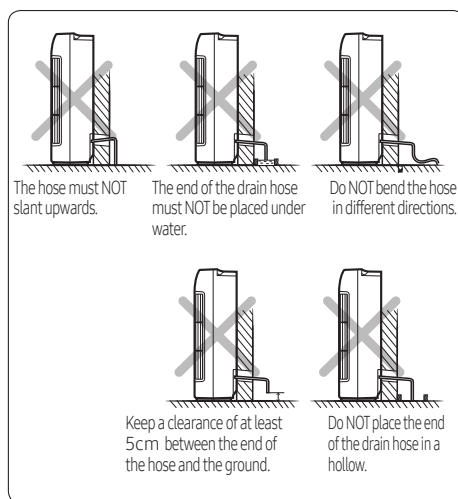

- 1 If necessary, connect the 2 m extension drain hose to the drain hose.

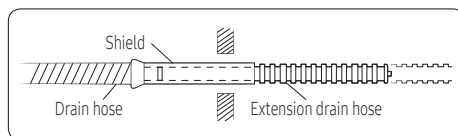

- 2 If you use the extension drain hose, insulate the outside of the extension drain hose with an insulation.
- 3 Fit the drain hose into 1 of 2 drain hose holes, then fix the end of the drain hose tightly with a clamp.
  - If you don't use the other drain hose hole, block it with a rubber stopper.
- 4 Pass the drain hose under the refrigerant pipes, keeping the drain hose tight.
- 5 Pass the drain hose through the hole in the wall. Verify that it slants downwards.

# Installation Procedure

## 6-ways for drain hose and drain pipe connection

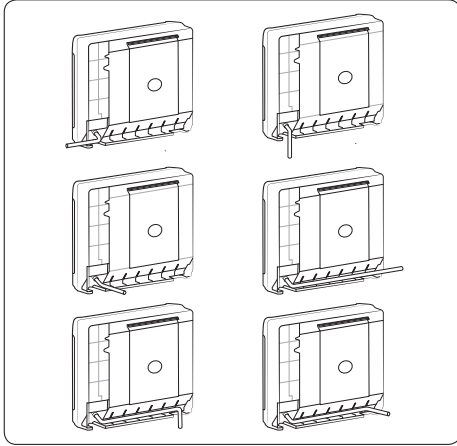

### Knock out

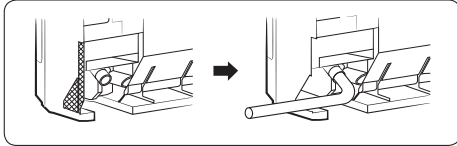

### NOTE

- The hose will be fixed permanently into position after finishing the installation and the gas leak test; refer to page 12 for further details.

## Step 10 Optional : Half concealed Installation

When installing this unit with a part in the wall, please keep the dimensions as shown below.

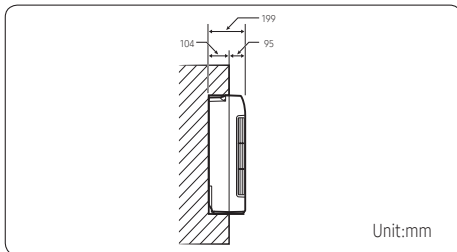

## Step 11 Connecting the power and communication cables

### CAUTION

- Always remember to connect the refrigerant pipes before performing the electric connections. When disconnecting the system, always disconnect the electric cables before disconnecting the refrigerant pipes.

### CAUTION

- Always remember to connect the air conditioner to the grounding system before performing the electric connections. Use a crimp ring terminal at the end of each wire.

The indoor unit is powered through the outdoor unit by means of a H07RN-F connection cable (or a more power model), with insulation in synthetic rubber and a jacket in polychloroprene (neoprene), in accordance with the requirements specified in the standard EN 60335-2-40.

- Remove the screw on the electrical component box and remove the cover plate.
- Route the connection cord through the side of the indoor unit and connect the cable to the terminals refer to the figure below.
- Route the other end of the cable to the outdoor unit through the ceiling & the hole on the wall.
- Reassemble the electrical component box cover, carefully tightening the screw.

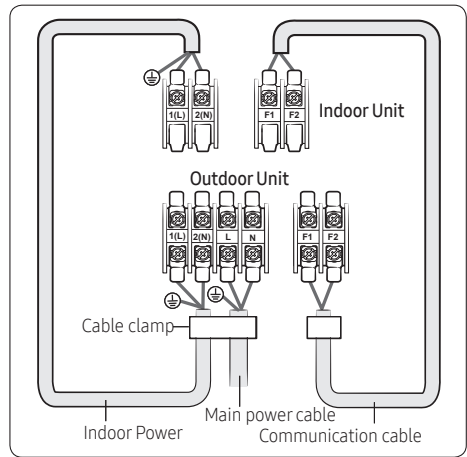

Indoor power supply		
Power supply	Max/Min(V)	Indoor power cable
220 to 240V, 50 Hz	±10%	0.75 mm <sup>2</sup> †, 3 wires
Communication cable		
0.75 mm <sup>2</sup> †, 2 wires		

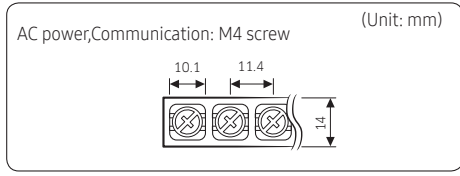

Tightening torque (kgf • cm)	
M4	12.0 to 18.0
<ul style="list-style-type: none"> <li>1 N•m = 10 kgf•cm</li> </ul>	

- Power supply cords of parts of appliances for outdoor use shall not be lighter than polychloroprene sheathed flexible cord. (Code designation IEC:60245 IEC 57 / CENELEC: H05RN-F or IEC:60245 IEC 66 / CENELEC: H07RN-F)
- Screws on terminal block must not be unscrewed with the torque less than 12 kgf•cm.
- Since it has the external power supply, refer to the outdoor unit installation manual for MAIN POWER.

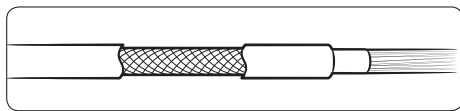

- CAUTION**
- When installing the indoor unit in a computer room or network room, use the double shielded communication cable (tape aluminum / polyester braid + copper) of FROHH2R or LiYCY type.

## Step 12 Optional: Extending the power cable

1 Prepare the following tools.

Tools	Spec	Shape
Crimping pliers	MH-14	
Connection sleeve (mm)	20xØ6.5 (HxOD)	
Insulation tape	Width 19 mm	
Contraction tube (mm)	70xØ8.0 (LxOD)	

2 As shown in the figure, peel off the shields from the rubber and wire of the power cable.

- Peel off 20 mm of cable shields from the pre-installed tube.

**CAUTION**

- For information about the power cable specifications for indoor and outdoor units, refer to the installation manual.
- After peeling off cable wires from the pre-installed tube, insert a contraction tube.
- If cable wires are connected without using connecting sleeves, their contact area becomes reduced, or corrosion develops on the outer surfaces of the wires (copper wires) over a long time. This may cause an increase of resistance (reduction of passing current) and consequently may result in a fire.

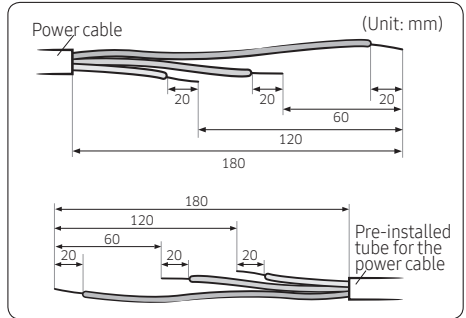

# Installation Procedure

3 Insert both sides of core wire of the power cable into the connection sleeve.

- **Method 1:** Push the core wire into the sleeve from both sides.
- **Method 2:** Twist the wire cores together and push it into the sleeve.

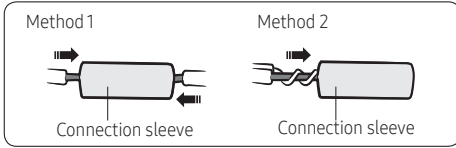

4 Using a crimping tool, compress the two points and flip it over and compress another two points in the same location.

- The compression dimension should be 8.0.



- After compressing it, pull both sides of the wire to make sure it is firmly pressed.

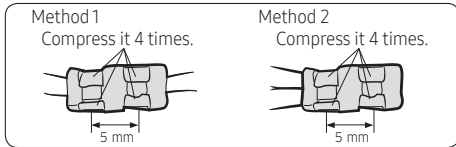

5 Apply heat to the contraction tube to contract it.

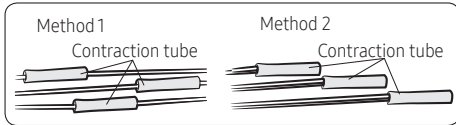

6 Wrap it with the insulation tape twice or more and position your contraction tube in the middle of the insulation tape. Three or more layers of insulation are required.

7 After tube contraction work is completed, wrap it with the insulation tape to finish.

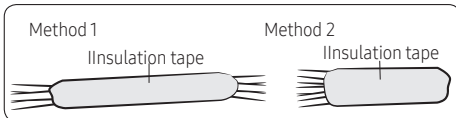

## ⚠ CAUTION

- Make sure that the connection parts are not exposed to outside.
- Be sure to use insulation tape and a contraction tube made of approved reinforced insulating materials that have the same level of withstand voltage with the power cable. (Comply with the local regulations on extensions.)

## ⚠ WARNING

- In case of extending the electric wire, please DO NOT use a round-shaped Pressing socket.
  - Incomplete wire connections can cause electric shock or a fire.

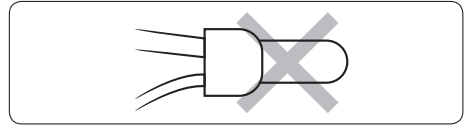

## Step 13 Optional : Setting the Emergency Temperature Output (ETO) function

**Emergency Temperature Output (ETO) function (for the multi system, this function is not supported.)**

### CAUTION

- In order to deploy the ETO function, the MIM-B14, an external contact interface module, must be installed in each indoor unit.
- The ETO is a concept of emergency operation of indoor units. If the indoor unit 1 (main indoor unit) stops because of an error, the indoor unit 2 (sub indoor unit) starts to operate.
- Basically, the indoor unit 2 operates in the previous mode. [For the first time operation, it starts in 24 °C Auto mode.]
- To set more detailed operation conditions for the indoor unit 2, use the S-net Pro.

### Setting up the ETO

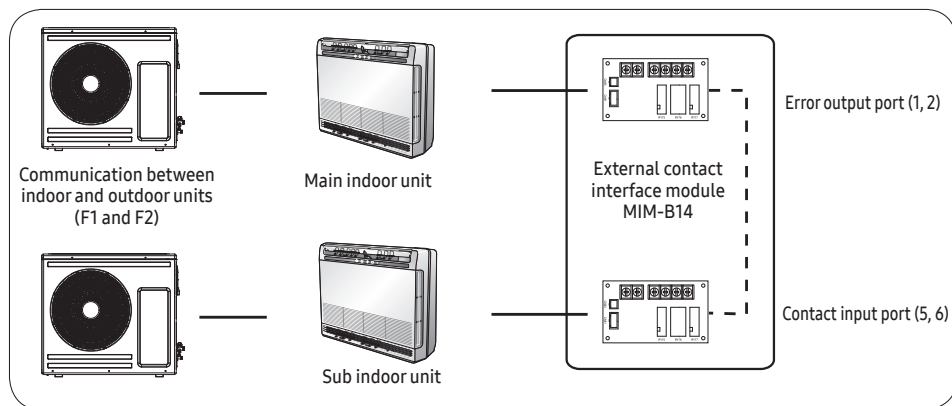

- 1 Main indoor unit
  - Disable the external contact control (Default).
  - Connect the S-net pro2 to F1 and F2.
  - Enable the ETO function and set the temperature and time.
- 2 Sub indoor unit
  - (Required) Enable the external contact control (with the installation option SEG14 - Reverse Control).
  - Connect the S-net pro2 to F1 and F2.
  - Enable the entrance control and set the mode, set temperature, and fan speed.

# Installation Procedure

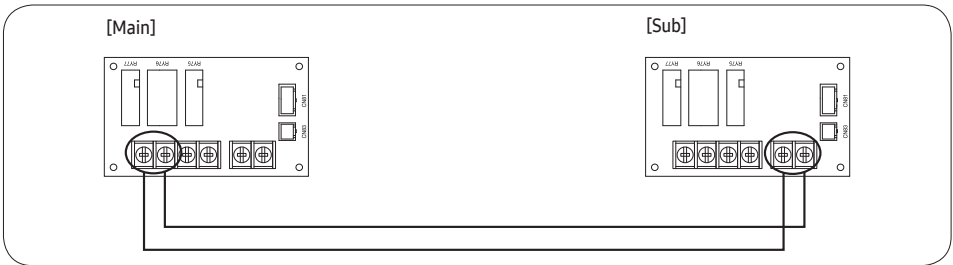

## ETO operation specifications

### 1 Main indoor unit

- Based on the external contact control settings, the main indoor unit decides whether to generate output when an error (indoor unit stop) occurs.
- Based on the ETO settings, the main indoor unit decides whether to generate output according to the temperature and time conditions.

### 2 Sub indoor unit

- Based on the entrance control settings, the sub indoor unit decides the mode, set temperature, and fan speed when contact inputs are given.

	Enable of ETO	Enable of external contact	Error port output
Main indoor unit	X	X	N/A
	X	O	Output due to an error
	O	X	Output by ETO entrance conditions (temperature / time / error occurrence)
	O	O	Output by ETO entrance conditions (temperature / time / error occurrence) * Ready to control the main contact input

	Enable of entrance control	Enable of external contact	Operation when outputting Main
Sub indoor unit	X	X	N/A
	X	O	On with the previous operation conditions
	O	O	On with the entrance control enabled



## Step 14 Optional : Connecting the External control (MIM-B14), Wired Remote Control and External Floating switch

After disassembling the body front and cover plate, you can connect the wires from the indoor unit' electrical component box to the External control(MIM-B14) and wired remote control, External floating switch.

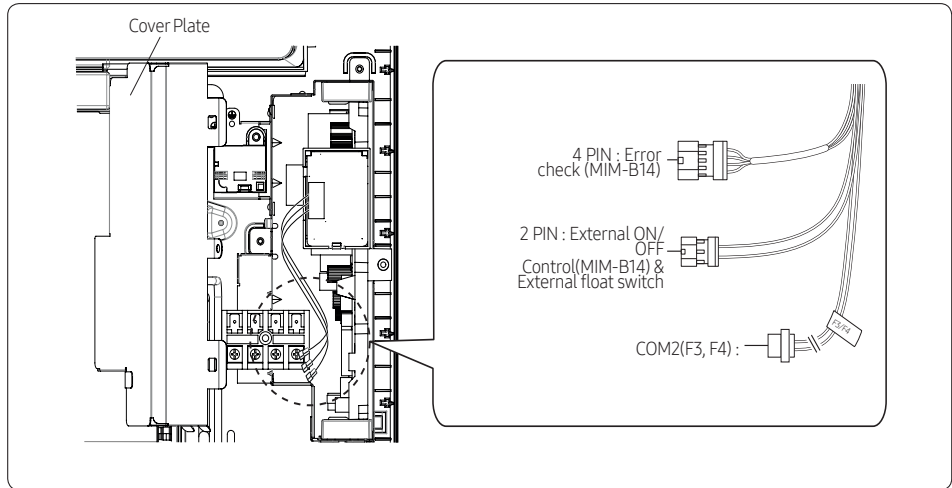

- External controller (MIM-B14) : Connect the wires of the external controller to 4PIN (Error check) and 2PIN (External On/ Off). (Refer to the manual of MIM-B14.)  
Next, set Install option (02 mode). (Refer to step15. Setting the indoor unit addresses and the installation options .)
- Wired Remote control : Be sure to connect the wired remote control for installation after cutting the COM2(F3,F4) wire.
- Connecting the External Floating switch :
  1. Connect the external float switch to the 2PIN wire.
  2. If the connector types of the external float switch and 2PIN wire do not match, cut off the end of the 2PIN wire before connecting the wire to the external float switch.
  3. Set SEG8 for the Install option (02 mode) to '8'. (Refer to "step15. Setting the indoor unit addresses and the installation options")

### NOTE

- The External Floating switch is not sold separately by Samsung.
- External Control (MIM-B14) and External Floating switch cannot be connected simultaneously. Only either of them can be connected at a time.

# Installation Procedure

## Step 15 Setting the indoor unit addresses and the installation options

- Set the indoor unit address and installation option with a wireless remote controller. Options and address can also be modified using wired controllers or service software. You cannot set both the indoor unit addresses and the installation options at the same time.
- Please use the proper wireless remote controller which can set 24 digit option code.
- Please refer to the wired remote controller installation manual for setting with the wired remote controller.

### Common steps for setting the addresses and options

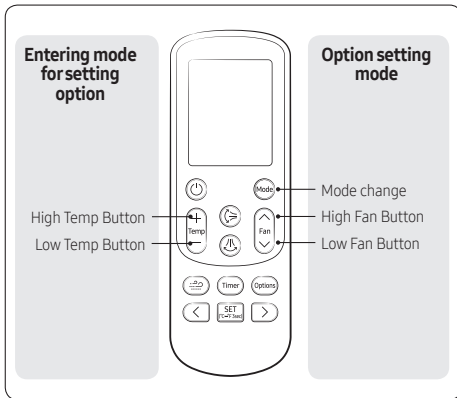

#### NOTE

- The remote control display and buttons may vary depending on the model.
- 1 Enter the mode for setting the options:
    - a Remove the batteries from the remote control, and then insert them again.
    - b While holding down the (High Temp) and (Low Temp) buttons simultaneously, insert the batteries into the remote control.
    - c Make sure that you are entered to the mode for setting the options:

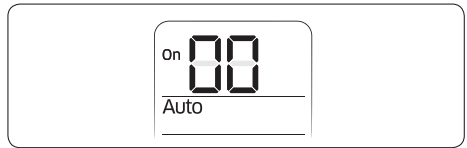

- 2 Set the option values.



















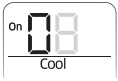
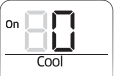



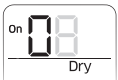
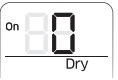

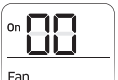
### CAUTION

- The total number of available options are 24: SEG1 to SEG24.
- Because SEG1, SEG7, SEG13, and SEG19 are the page options used by the previous remote control models, the modes to set values for these options are skipped automatically.
- Set a 2-digit value for each option pair in the following order: SEG2 and SEG3 → SEG4 and SEG5 → SEG6 and SEG8 → SEG9 and SEG10 → SEG11 and SEG12 → SEG14 and SEG15 → SEG16 and SEG17 → SEG18 and SEG20 → SEG21 and SEG22 → SEG23 and SEG24







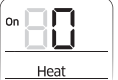















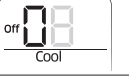
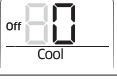
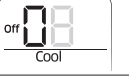
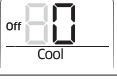
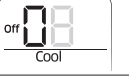
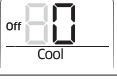



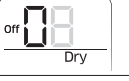
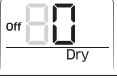
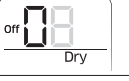
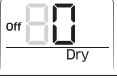
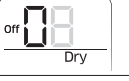
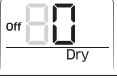







SEG1	SEG2	SEG3	SEG4	SEG5	SEG6
0	X	X	X	X	X
SEG7	SEG8	SEG9	SEG10	SEG11	SEG12
1	X	X	X	X	X
SEG13	SEG14	SEG15	SEG16	SEG17	SEG18
2	X	X	X	X	X
SEG19	SEG20	SEG21	SEG22	SEG23	SEG24
3	X	X	X	X	X

On (SEG1 to SEG12)	Off (SEG13 to SEG24)

Take the steps presented in the following table:

Option setting	Status	
<p>1 Setting SEG2, SEG3 option</p> <p>Press Low Fan button  to enter SEG2 value.</p> <p>Press High Fan button  to enter SEG3 value.</p> <p>Each time you press the button, 0 - 1 - ... - E - F will be selected in rotation.</p>	 <p>SEG2</p>	 <p>SEG3</p>
<p>2 Setting <b>Cool</b> mode</p> <p> Press <b>Mode</b> button to be changed to <b>Cool</b> mode in the ON status.</p>		
<p>3 Setting SEG4, SEG5 option</p> <p>Press Low Fan button  to enter SEG4 value.</p> <p>Press High Fan button  to enter SEG5 value.</p> <p>Each time you press the button, 0 - 1 - ... - E - F will be selected in rotation.</p>	 <p>SEG4</p>	 <p>SEG5</p>
<p>4 Setting <b>Dry</b> mode</p> <p> Press <b>Mode</b> button to be changed to <b>Dry</b> mode in the ON status.</p>		
<p>5 Setting SEG6, SEG8 option</p> <p>Press Low Fan button  to enter SEG6 value.</p> <p>Press High Fan button  to enter SEG8 value.</p> <p>Each time you press the button, 0 - 1 - ... - E - F will be selected in rotation.</p>	 <p>SEG6</p>	 <p>SEG8</p>
<p>6 Setting <b>Fan</b> mode</p> <p> Press <b>Mode</b> button to be changed to <b>Fan</b> mode in the ON status.</p>		
<p>7 Setting SEG9, SEG10 option</p> <p>Press Low Fan button  to enter SEG9 value.</p> <p>Press High Fan button  to enter SEG10 value.</p> <p>Each time you press the button, 0 - 1 - ... - E - F will be selected in rotation.</p>	 <p>SEG9</p>	 <p>SEG10</p>
<p>8 Setting <b>Heat</b> mode</p> <p> Press <b>Mode</b> button to be changed to <b>Heat</b> mode in the ON status.</p>		
<p>9 Setting SEG11, SEG12 option</p> <p>Press Low Fan button  to enter SEG11 value.</p> <p>Press High Fan button  to enter SEG12 value.</p> <p>Each time you press the button, 0 - 1 - ... - E - F will be selected in rotation.</p>	 <p>SEG11</p>	 <p>SEG12</p>

# Installation Procedure

Option setting	Status				
<p><b>10</b> Setting <b>Auto</b> mode</p> <p>Press <b>Mode</b> button to be changed to <b>Auto</b> mode in the OFF status.</p>					
<p><b>11</b> Setting SEG14, SEG15 option</p> <p>Press Low Fan button  to enter SEG14 value.</p> <p>Press High Fan button  to enter SEG15 value.</p> <p>Each time you press the button, 0 - 1 - ... - E - F will be selected in rotation.</p>	<table border="1" style="width: 100%; text-align: center;"> <tr> <td data-bbox="729 400 869 480">  </td> <td data-bbox="891 400 1011 480">  </td> </tr> <tr> <td data-bbox="729 483 869 512">SEG14</td> <td data-bbox="891 483 1011 512">SEG15</td> </tr> </table>			SEG14	SEG15
					
SEG14	SEG15				
<p><b>12</b> Setting <b>Cool</b> mode</p> <p>Press <b>Mode</b> button to be changed to <b>Cool</b> mode in the OFF status.</p>					
<p><b>13</b> Setting SEG16, SEG17 option</p> <p>Press Low Fan button  to enter SEG16 value.</p> <p>Press High Fan button  to enter SEG17 value.</p> <p>Each time you press the button, 0 - 1 - ... - E - F will be selected in rotation.</p>	<table border="1" style="width: 100%; text-align: center;"> <tr> <td data-bbox="729 627 869 707">  </td> <td data-bbox="891 627 1011 707">  </td> </tr> <tr> <td data-bbox="729 710 869 738">SEG16</td> <td data-bbox="891 710 1011 738">SEG17</td> </tr> </table>			SEG16	SEG17
					
SEG16	SEG17				
<p><b>14</b> Setting <b>Dry</b> mode</p> <p>Press <b>Mode</b> button to be changed to <b>Dry</b> mode in the OFF status.</p>					
<p><b>15</b> Setting SEG18, SEG20 option</p> <p>Press Low Fan button  to enter SEG18 value.</p> <p>Press High Fan button  to enter SEG20 value.</p> <p>Each time you press the button, 0 - 1 - ... - E - F will be selected in rotation.</p>	<table border="1" style="width: 100%; text-align: center;"> <tr> <td data-bbox="729 853 869 933">  </td> <td data-bbox="891 853 1011 933">  </td> </tr> <tr> <td data-bbox="729 936 869 965">SEG18</td> <td data-bbox="891 936 1011 965">SEG20</td> </tr> </table>			SEG18	SEG20
					
SEG18	SEG20				
<p><b>16</b> Setting <b>Fan</b> mode</p> <p>Press <b>Mode</b> button to be changed to <b>Fan</b> mode in the OFF status.</p>					
<p><b>17</b> Setting SEG21, SEG22 option</p> <p>Press Low Fan button  to enter SEG21 value.</p> <p>Press High Fan button  to enter SEG22 value.</p> <p>Each time you press the button, 0 - 1 - ... - E - F will be selected in rotation.</p>	<table border="1" style="width: 100%; text-align: center;"> <tr> <td data-bbox="729 1080 869 1160">  </td> <td data-bbox="891 1080 1011 1160">  </td> </tr> <tr> <td data-bbox="729 1163 869 1192">SEG21</td> <td data-bbox="891 1163 1011 1192">SEG22</td> </tr> </table>			SEG21	SEG22
					
SEG21	SEG22				
<p><b>18</b> Setting <b>Heat</b> mode</p> <p>Press <b>Mode</b> button to be changed to <b>Heat</b> mode in the OFF status.</p>					
<p><b>19</b> Setting SEG23, SEG24 option</p> <p>Press Low Fan button  to enter SEG23 value.</p> <p>Press High Fan button  to enter SEG24 value.</p> <p>Each time you press the button, 0 - 1 - ... - E - F will be selected in rotation.</p>	<table border="1" style="width: 100%; text-align: center;"> <tr> <td data-bbox="729 1307 869 1386">  </td> <td data-bbox="891 1307 1011 1386">  </td> </tr> <tr> <td data-bbox="729 1390 869 1418">SEG23</td> <td data-bbox="891 1390 1011 1418">SEG24</td> </tr> </table>			SEG23	SEG24
					
SEG23	SEG24				

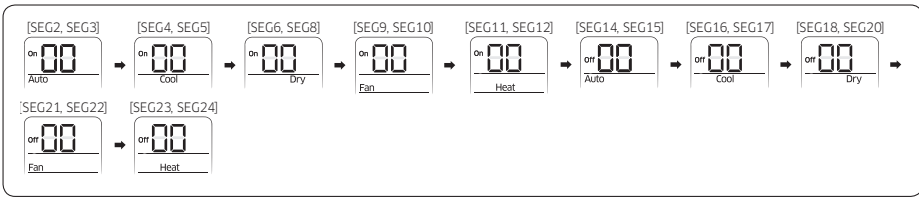

3 Check whether the option values that you have set are correct by pressing the  button repeatedly.



4 Save the option values into the indoor unit:

Press the  button with the direction of remote control for set. For correcting option values, input the option values twice.

5 Check whether the air conditioner operates in accordance with the option values you have set:

- a Reset the indoor or outdoor unit.
  - Indoor unit : Press the  (Set) and  (Low Fan) buttons on the remote control simultaneously for 4 seconds.
  - Outdoor unit : Press the K3 button.
- b Remove the batteries from the remote control, insert them again, and then press the  button on the remote control.

# Installation Procedure

## Setting the indoor unit addresses

**Option No. for an indoor unit address: 0AXXXX-1XXXXX-2XXXXX-3XXXXX**

Before installing an indoor unit, be sure to set an address for the indoor unit by taking the following steps:

- 1 Make sure that the power is supplied to the indoor unit. If the indoor unit is not plugged in, it must include a power supply.
- 2 Set an address for each indoor unit using the remote control, according to your air conditioning system plan, by referring to the following table and by following the steps in **Common steps for setting the addresses and options on page 20**.
  - The indoor unit addresses (main and RMC addresses) are set to 0A0000-100000-200000-300000 by default.
  - If indoor units and outdoor units match 1:1, you don't need to set the main address because it is automatically set by the outdoor unit.
  - If you are using on or off controller, set RMC address.

Option	SEG1		SEG2		SEG3		SEG4	SEG5		SEG6	
Function	Page		Mode		Setting main address		Reserved	Indoor unit number		Indoor unit number	
Indication and details	Indication	Details	Indication	Details	Indication	Details		Indication	Details	Indication	Details
	0		A		0	No main address		0 to 1	Tens digit	0 to 9	Units digit
					1	Main address setting mode					
Option	SEG7		SEG8		SEG9		SEG10	SEG11		SEG12	
Function	Page		Reserved		Setting RMC address		Reserved	Group channel (x16)		Group address	
Indication and details	Indication	Details			Indication	Details		Indication	Details	Indication	Details
	1				0	No RMC address		RMC1	0 to 2	RMC2	0 to F
			1	RMC address setting mode							

### CAUTION

- The main address must be set to a value in the range 0 to 15. If you set other values, communication error will occur.
- If any of SEG5 and SEG6 is set to a value in the range A to F, the main address of the indoor unit does not change.
- If SEG3 is set to 0, the indoor unit maintains the existing main address even if SEG6 is set to a new value.
- If SEG9 is set 0, the indoor unit maintains the existing RMC address even if SEG11 and SEG12 are set to new values.

Example) If you want to set as "MAIN: 3, CHANNEL: 1, RMC: B",

SEG1	SEG2	SEG3	SEG4	SEG5	SEG6
0	A	1	-	-	3
SEG7	SEG8	SEG9	SEG10	SEG11	SEG12
1	-	1	-	1	B

assign option codes except SEG 1, 7 which are page options.

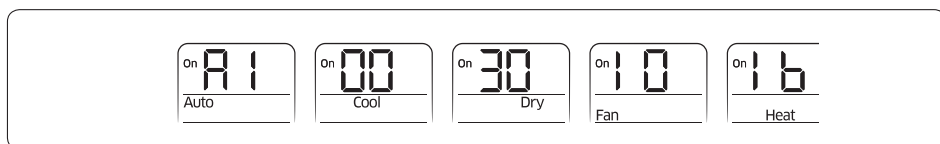

## Setting the installation options in a batch

**Installation option No. for an indoor unit address: 02XXXX-1XXXX-2XXXX-3XXXX**

- 1 Make sure that the power is supplied to the indoor unit. If the indoor unit is not plugged in, it must include a power supply.
- 2 Set the installation options of indoor units, by referring to the following table and by following the steps in **Common steps for setting the addresses and options on page 20**.
  - The installation options of indoor units are set to 020010-100000-200000-300000 by default.
  - The SEG20 option, Individual control with remote control, allows you to control multiple indoor units individually by using the remote control.

Option	SEG1	SEG2	SEG3	SEG4	SEG5	SEG6		
Function	Page	Mode	Reserved	Use of external room temperature sensor / Minimizing fan operation when thermostat is off <sup>1)</sup>	Central control			
Indication and details	Indication	Details		Indication	Details		Indication	
					Use of external room temperature sensor	Minimizing fan operation when thermostat is off <sup>1)</sup>		Details
	0	2		0			Disuse	
				1	Use			
				2	Disuse	Use(Heating)		
				3	Use	Use(Heating)		
				4	Disuse	Use(Cooling)		
				5	Use	Use(Cooling)		
				6	Disuse	Use (Cooling/Heating)		
				7	Use	Use (Cooling/Heating)		
				8	Disuse	Use (Cooling Ultra low speed)		
				9	Use	Use (Cooling Ultra low speed)		
	A	Disuse	Use (Heating/Cooling Ultra low speed)	1	Use			
B	Use	Use (Heating/Cooling Ultra low speed)						



# Installation Procedure

Option	SEG7		SEG8		SEG9	SEG10	SEG11	SEG12								
Function	Page		Use of drain pump <sup>2)</sup>		Reserved	Reserved	Reserved	Reserved								
Indication and details	Indication	Details	Indication	Details												
	1		0	Disuse												
			8	Use external drain pump												
Option	SEG13		SEG14		SEG15		SEG16	SEG17		SEG18						
Function	Page		Use of external control		Setting the output of external control <sup>3)</sup>		Reserved	Buzzer control		Maximum filter usage time <sup>4)</sup>						
Indication and details	2	Indication	Details	Indication	Details	Indication		Details	0	Use of buzzer	2	1000 hours				
													Sub, Existing control	0	Disuse	1
							1							On/Off		
							2		Off							
							Main, Existing control		3	Window On/Off	1	Operation On				
									4	Disuse						
									5	On/Off						
							Sub, Reverse control		6	Off	1	Operation On				
									7	Window On/Off						
									8	Disuse						
							Main, Reverse control		9	On/Off	1	Operation On				
									A	Off						
									B	Window On/Off						
									C	Disuse						
D	On/Off															
E	Off															
F	Window On/Off															
Option	SEG19		SEG20		SEG21		SEG22	SEG23	SEG24							
Function	Page		Individual control with remote control <sup>5)</sup>		Heating setting compensation <sup>6)</sup>		Reserved	Reserved	Reserved							
Indication and details	3	Indication	Details	Indication	Details	Indication				Details						
											0 or 1	Indoor1	0	Default		
											2	Indoor2	1	2°C		
											3	Indoor3	2	5°C		
							4	Indoor4								

• 1) SEG4

By SEG4 setting, Minimizing fan operation when thermostat is off.

- Fan operates for 20 seconds at an interval of 5 minutes in heat mode.

- Fan stops or operates Ultra low in Cooling when thermostat is off.

• 2) SEG8

For information on how to connect the external float switch, refer to STEP14 of this manual.

• 3) SEG15

The external output of SEG15 is generated by MIM-B14 connection. (Refer to the manual of MIM-B14)

• 4) SEG18

If you set the Maximum filter usage time option to a value other than 2 and 6, it is automatically set to 2 (1000 hours).

• 5) SEG20

If you set the Individual control with remote control option to a value other than 0 to 4, it is automatically set to 0 (Indoor1)

• 6) SEG21

Default value of Heating setting compensation is 5°C.

## Changing the addresses and options individually

Example) If you want to set as "MAIN : 3, CHANNEL : 1, RMC : B",

Option	SEG1		SEG2		SEG3		SEG4		SEG5		SEG6	
Explanation	PAGE		MODE		The option mode you want to change		The tens' digit of an option SEG you will change		The unit digit of an option SEG you will change		The changed value	
Indication and Details	Indication	Details	Indication	Details	Indication	Details	Indication	Details	Indication	Details	Indication	Details
		0		D	Option mode	0-F	Tens' digit of SEG	0-9	Unit digit of SEG	0-9	The changed value	0-F

### NOTE































- When changing a digit of an indoor unit address setting option, set the SEG3 as 'A'.
- When changing a digit of indoor unit installation option, set the SEG3 as '2'.

Example) When setting the 'buzzer control' into disuse status.

Option	SEG1		SEG2		SEG3		SEG4		SEG5		SEG6	
Explanation	PAGE		MODE		The option mode you want to change		The tens' digit of an option SEG you will change		The unit digit of an option SEG you will change		The changed value	
Indication	0		D		2		1		7		1	

# Troubleshooting

- If an error occurs during the operation, one or more LED flickers and the operation is stopped except the LED.
- If you re-operate the air conditioner, it operates normally at first, then detect an error again.

Abnormal condition	Error code	LED Display				
		...				
Error on indoor temperature sensor (Short or Open)	E121	X	X		X	X
1. Error on Eva-in sensor (Short or Open) 2. Error on Eva-out sensor (Short or Open)	E122 E123	X	X		X	
Indoor fan error	E154	X		X	X	X
1. Error on outdoor temperature sensor (Short or Open) 2. Error on cond sensor 3. Error on discharge sensor Other outdoor unit sensor error that is not on the above list	E221 E237 E251	X		X	X	
1. When there is no communication between the indoor-outdoor units for 2 minutes 2. Communication error received from the outdoor unit 3. 3 minute tracking error on outdoor unit 4. Communication error after tracking due to unmatching number of installed units 5. Error due to repeated communication address 6. Communication address not confirmed Other outdoor unit communication error that is not on the above list	E101 E102 E202 E201 E108 E109	X			X	X
Self diagnosis error display 1. Thermal fuse error (Open)	E198				X	X
1. Refrigerant leakage (2nd detection) 2. Abnormally high temperature on Cond (2nd detection) 3. Low pressure s/w (2nd detection) 4. Abnormally high temperature on discharged air on outdoor unit (2nd detection) 5. Indoor operation stop due to unconfirmed error on outdoor unit 6. Error due to reverse phase detection 7. Comp stop due to freeze detection (6th detection) 8. High pressure sensor is detached 9. Low pressure sensor is detached 10. Outdoor unit compression ration error 11. Outdoor sump down_1 prevention control 12. Compressor down due to low pressure sensor prevention control_1 Other outdoor unit self-diagnosis error that is not on the above list	E554 E450 E451 E416 E559 E425 E403 E301 E306 E428 E413 E410				X	X
Floating Switch (2nd detection)	E153			X	X	X
External floating switch error	E665					
EEPROM error	E162					
EEPROM option error	E163					

● : On,  : Flickering, X : Off

If you turn off the air conditioner when the LED is flickering, the LED is also turned off.



**SAMSUNG**