

16NK

DOUBLE-EFFECT STEAM-FIRED ABSORPTION CHILLERS

Technical data

16NK		11	12	13	21	22	31	32	41	42
Cooling capacity	kW	345	447	549	689	861	1034	1238	1378	1551
Chilled-water system*										
Flow rate	l/s	14.8	19.2	23.6	29.7	37.2	44.4	53.3	59.4	66.7
Pressure drop	kPa	44	64	64	57	42	41	49	46	41
Connection (ANSI)	in	4	4	4	5	6	6	6	8	8
Retention volume	m ³	0.13	0.15	0.17	0.24	0.28	0.34	0.36	0.46	0.48
Cooling water system*										
Flow rate	l/s	24.7	31.9	39.4	49.4	61.9	74.2	88.9	98.9	111.4
Pressure drop	kPa	68	40	49	109	74	53	65	67	73
Connection (ANSI)	in	5	5	5	6	8	8	8	10	10
Retention volume	m ³	0.34	0.38	0.42	0.58	0.63	0.89	0.95	1.11	1.90
Steam system		Saturated steam 784 kPa								
Consumption	kg/h	400	510	630	790	980	1180	1410	1570	1770
Dimensions										
Length A	mm	2810	3850	3850	3880	4920	5040	5040	5100	5100
Height B	mm	2200	2200	2200	2250	2250	2390	2390	2600	2600
Width C	mm	2050	1910	1910	2240	2070	2170	2170	2400	2400
Operating weight	kg	4600	5800	6100	7500	8800	11200	11800	13900	14500
Power supply	V-ph-Hz	400-3-50								
Total current drawn	A	10.8	10.8	10.8	13.3	13.3	13.6	13.6	20.7	20.7

16NK		51	52	53	61	62	63	71	72	81
Cooling capacity	kW	1723	1927	2170	2412	2757	3101	3446	3963	4652
Chilled-water system*										
Flow rate	l/s	74.2	83.1	93.9	103.9	118.6	133.6	148.3	170.6	200.3
Pressure drop	kPa	98	46	61	123	83	78	54	81	84
Connection (ANSI)	in	8	8	8	10	10	10	12	12	14
Retention volume	m ³	0.65	0.71	0.77	0.99	1.06	1.13	1.41	1.61	1.94
Cooling water system**										
Flow rate	l/s	123.6	138.3	155.6	173.1	197.8	222.5	247.2	284.4	333.9
Pressure drop	kPa	53	71	94	61	83	111	77	113	122
Connection (ANSI)	in	12	12	12	14	14	14	16	16	16
Retention volume	m ³	1.87	2.01	2.14	2.79	2.97	3.15	3.67	4.11	4.76
Steam system		Saturated steam 784 kPa								
Consumption	kg/h	1960	2200	2470	2750	3140	3530	3920	4510	5300
Dimensions										
Length A	mm	5330	5870	6370	6100	6190	6710	6440	7460	7460
Height B	mm	2900	2900	2900	3330	3330	3330	3450	3450	3650
Width C	mm	2770	2800	2800	2970	3000	3000	3300	3300	3500
Operating weight	kg	18800	20800	22300	26500	30000	32100	38000	42300	47300
Power supply	V-ph-Hz	400-3-50								
Total current drawn	A	22.7	24.5	24.5	25.5	25.0	25.0	33.5	33.5	33.5

Cooling per ARI 560 2000:

* 12.2 → 6.7°C (fouling factor = 0.0176 m² K/kW)

** 29.4 → 35.4°C (fouling factor = 0.044 m² K/kW)

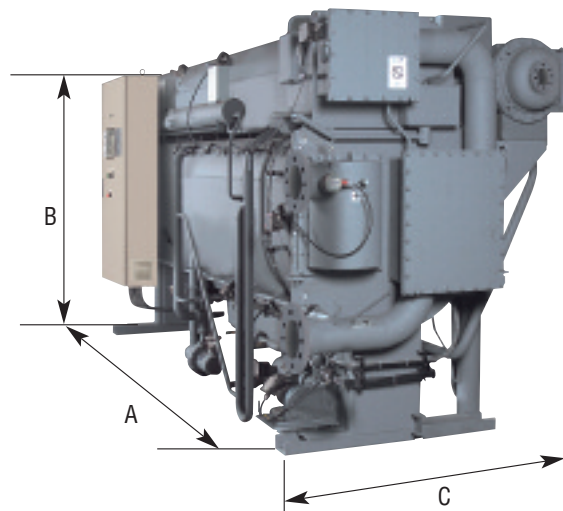

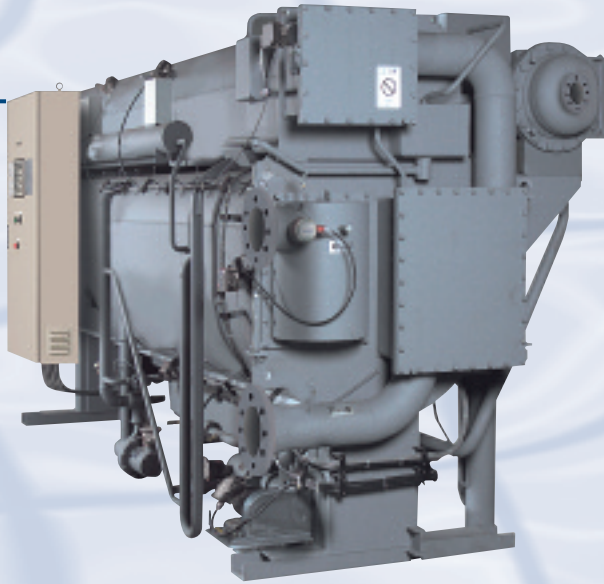

SUPER ABSORPTION

FEATURES

- Eighteen sizes with nominal cooling capacities from 345 to 4652 kW.
- The 16NK absorption chillers are designed for cooling applications where low-pressure steam is available as waste heat.
- Can tie into district steam systems.
- Allows diversification of critical cooling requirements. Critical cooling loads are met with minimal electrical power input.
- Allows use of smaller emergency generators since the electrical load associated with an absorption chiller is minimal.
- Ozone-friendly and CFC-free.
- Minimises global warming effect by greatly reducing power consumption and eliminating the generation of greenhouse gases.
- Reduced noise and vibration levels. The absorption chiller does not use a large motor-compressor, leading to quiet, vibration-free operation.
- Small footprint. The high efficiency associated with double-effect chillers results in a reduction of the required installation space.
- Auto-diagnosis system monitors operating conditions, predicts chiller information and maintains stable operation.
- Advanced high-precision control system
- Absorption pump with inverter control for efficient, energy-saving operation.
- High-performance purge system minimises maintenance requirements.
- State-of-the-art protection devices guarantee enhanced operating safety.

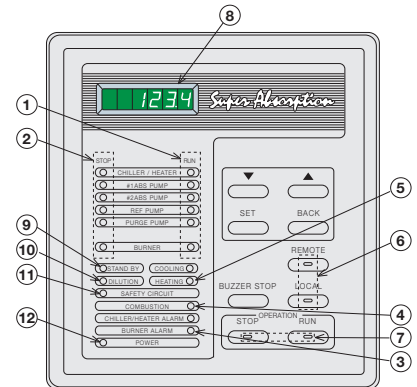

DISPLAY AND CONTROL BOARD

- 1 Operation indication
- 2 Stop indication
- 3 Alarm indication
- 4 Combustion indication
- 5 Cooling/heating indication
- 6 Remote/local select button
- 7 Operation mode selection
- 8 Data display
- 9 Stand-by indication
- 10 Dilution indication
- 11 Safety circuit indication
- 12 Power indication