

# Panasonic



DOMESTIC RANGE  
2024 / 2025



—ETHEREA—

heating & cooling solutions



## Panasonic domestic air to air heat pump

Panasonic has developed a range of products designed for you, better than ever before. Above all, it is also a range for air conditioning professionals, such as yourself, thanks to its broad range of products which are capable of conditioning rooms of all sizes – always with optimal efficiency and incomparable ease of installation.

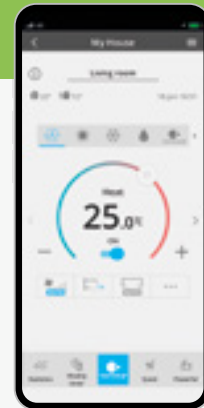



Highlighted features	→ 4
Bringing nature's balance indoors	→ 6
Etherea with nanoe™ X technology	→ 8
Heatcharge. Energy Charge System	→ 10
Wall-mounted TZ super-compact	→ 12
Super-compact units	→ 14
Floor console	→ 16
Power Heat Multi system	→ 18
Panasonic R2 rotary compressor	→ 20
R22 Renewal	→ 22
Panasonic Comfort Cloud App	→ 24
Voice Control	→ 26
Control and connectivity	→ 28
Domestic air conditioner R32 range	→ 30

### Wall-mounted

Heatcharge VZ · R32	→ 32
Etherea · R32	→ 33
TZ super-compact · R32	→ 34
BZ super-compact · R32	→ 35
UZ super-compact · R32	→ 36

### More options for your home

Floor console · R32	→ 37
Low static pressure hide-away · R32	→ 38
RAC Solo · R290 / R32	→ 46

### Multi split systems

Free Multi system	→ 42
Power Heat Multi system	→ 44
Multi TZ system	→ 45

Compare split solutions	→ 39
Single split feature overview	→ 48
Features explained	→ 49

Accessories and control	→ 50
-------------------------	------

## Highlighted features

With innovative design, high efficiency and advanced technologies, such as the Panasonic Comfort Cloud App for smart control and nanoe™ X for indoor air quality improvement, the residential range has been designed with you and your clients in mind.



## Panasonic air conditioners provide more savings and more comfort.

We believe that going green shouldn't compromise on comfort.

Our super silent air conditioners guarantee clean indoor air for you and your family. For a cleaner living environment, the nanoe™ X helps improve the quality of the indoor air as well as your surroundings. Together, these breakthrough technologies embody Panasonic's Eco Clean Life Innovation - innovations that improve our environment whilst making life as comfortable as possible.

The iF Product Design Awards are among the most prestigious awards for product design excellence. Winning the award thanks to its highly intelligent functionality, the Panasonic Floor console is the ideal air-conditioning system for domestic and commercial applications.



### Energy saving



#### Natural refrigerant R290 with GWP 3.

Natural refrigerant R290 has low Global Warming Potential (GWP) of just 3, helping reduce CO<sub>2</sub> emissions and environmental impact.



#### Refrigerant R32.

Our heat pumps containing R32 refrigerant show a drastic reduction in the value of Global Warming Potential (GWP).



#### Exceptional seasonal cooling efficiency based on the ErP regulation.

Higher SEER ratings mean greater efficiency and year-round cooling savings!



#### Exceptional seasonal heating efficiency based on the ErP regulation.

Higher SCOP ratings mean greater efficiency and year-round heating savings!



#### Econavi. Sunlight sensor.

Sunlight Sensor technology can detect and reduce the waste of energy by optimising air conditioner operation according to room conditions. With just one touch of a button, you can save energy.



#### Inverter Plus system.

Inverter Plus system classification highlights Panasonic's highest performing systems.



#### Inverter.

The Inverter range provides greater efficiency and comfort. Provides more precise temperature control, without highs and lows, and keeps the ambient temperature constant with lower energy consumption and a significant reduction in noise and vibration levels.



#### Panasonic R2 rotary compressor.

Designed to withstand extreme conditions, it delivers high performance and efficiency.

### High performance and indoor air quality



#### nanoe™ X.

Technology with the benefits of hydroxyl radicals has the capacity to inhibit pollutants, viruses, and bacteria to clean and deodorise.



#### PM2,5 filter.

This filter can capture airborne particulate matter (PM2,5), including hazardous pollutants, as well as house dust and pollen.



#### Dust collection filter.

This filter collects and retains particles suspended in the air, resulting in cleaner air in the room.



#### Super Quiet.

With Super Quiet technology our devices are quieter than a library (30 dB(A)).



#### Inside cleaning.

This function works to dry-off to inside of indoor unit with nanoe™ X. It can inhibit certain adhered bacteria, viruses and mould up to 99% efficiency.



#### Mild Dry cooling.

Fine control helps prevent a rapid decrease in room humidity while maintaining the set temperature. Maintains an RH\* up to 10% higher than cooling operation (\*RH: Relative Humidity). Ideal when sleeping with the air conditioner on.



#### More comfort with Aerowings.

Panasonic's Aerowings feature incorporates two blades that concentrate the air flow to cool or heat in the shortest possible time by distributing the air evenly throughout the room.



#### Static pressure up to 7 mmAq.

Low static pressure hide-away with selectable static pressure up to 7 mmAq.



#### Filter included.

Hide-away with filter included.



#### Summer House.

This innovative function keeps the house at 8/10 or 8/15 °C to avoid freezing pipes during the winter. This function is beneficial for summer or weekend homes.



#### Down to -10 °C in cooling mode.

The air conditioner works in cooling mode when the outdoor temperature of -10 °C.



#### Down to -15 °C in heating mode.

The air conditioner works in heat pump mode when the outdoor temperature is as low as -15 °C.



#### R410A/R22 renewal.

The Panasonic renewal system allows good quality existing R410A or R22 pipe work to be re-used whilst installing high efficiency R32 systems.



#### 5 Years compressor warranty.

We guarantee the outdoor unit compressors in the entire range for five years.

### High connectivity



#### Domestic integration to S-Link - CZ-CAPRA1.

Can connect RAC range to S-Link. Full control is now possible.



#### Wi-Fi control.

The Panasonic Comfort Cloud App allows users to conveniently manage and monitor Panasonic residential heat pumps from a mobile device, anytime, anywhere.



#### BMS connectivity.

The communication port can be integrated into the indoor unit and provides easy connection to, and control of, your Panasonic air conditioner to your home or Building Management System.

# Bringing nature's balance indoors



nanoe™ X, technology with the benefits of hydroxyl radicals.

Abundant in nature, hydroxyl radicals (also known as OH radicals) have the capacity to inhibit pollutants, viruses, and bacteria to clean and deodorise. nanoe™ X technology can bring these incredible benefits indoors so that hard surfaces, soft furnishings, and the indoor environment can be a cleaner and more pleasant place to be.



## What is unique about nanoe™ X?

**Effective on fabrics and surfaces.**

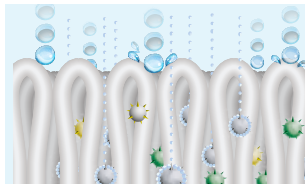

1 | At one billionth of a metre, nanoe™ X is much smaller than steam and can deeply penetrate cloth fabrics to deodorise.

**Longer lifespan.**



2 | Contained in tiny water particles, nanoe™ X has a long lifespan, which is about 600 seconds, to spread easily around the room.

**Huge quantity.**



3 | nanoe X Generator Mark 3 produces 48 trillion hydroxyl radicals per second. Greater amounts of hydroxyl radicals contained in nanoe™ X lead to higher performance on inhibition of pollutants.

**Maintenance-free.**

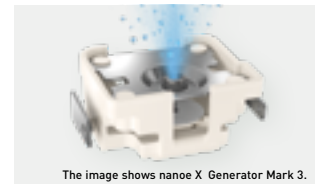

The image shows nanoe X Generator Mark 3.

4 | No service and maintenance required. nanoe™ X is a filter free solution that does not require maintenance, as its atomisation electrode is enveloped with water during its generation process and it is made with Titanium.

## 7 effects of nanoe™ X – Panasonic unique technology

**Deodorises**

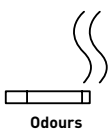

Odours

**Capacity to inhibit 5 types of pollutants**

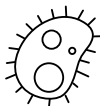

Bacteria and viruses



Mould

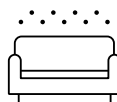

Allergens



Pollen



Hazardous substances



Skin and hair

\* Refer to <https://aircon.panasonic.eu> for more details and validation data.

## First nanoe™ device was developed by Panasonic in 2003

**Generator: nanoe™**

2003

480 billion hydroxyl radicals/sec

**Ion particle structure**

Hydroxyl radicals

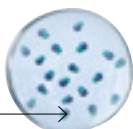

**Generator: nanoe™ X**

**Mark 1 - 2016**

4,8 trillion hydroxyl radicals/sec

10x times

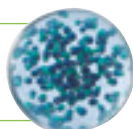

**Mark 2 - 2019**

9,6 trillion hydroxyl radicals/sec

20x times

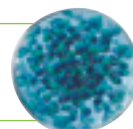

**Mark 3 - 2022**

48 trillion hydroxyl radicals/sec

100x times

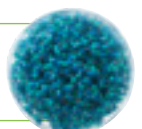

## nanoe™ X, internationally-validated technology in testing facilities.

The effectiveness of nanoe™ X technology has been tested by 3rd party laboratories in Germany, France, Denmark, Japan and China.

The nanoe™ X performance varies depending on the room size, environment and usage and it may take several hours to reach the full effect. nanoe™ X is not medical device, local regulations on building design and sanitary recommendations must be followed. Test results conducted under controlled laboratory conditions. Performance of nanoe™ X might differ in real life environment.

	Tested contents	Generator	Result	Capacity	Time	Testing organisation	Report No.	
Airborne	Virus	Influenza (H1N1)	98,3% inhibited	30 m³	1,5 h	China Electronic Product Reliability and Environmental Testing Research Institute	J2003WT8888-00889	
		Bacteriophage ΦX174	99,2% inhibited	Approx. 25 m³	6 h	Kitasato Research Center for Environmental Science	24_0300_1	
	Bacteria	Staphylococcus aureus	99,7% inhibited	Approx. 25 m³	4 h	Kitasato Research Center for Environmental Science	24_0301_1	
Adhering	Virus	SARS-CoV-2	91,4% inhibited	6,7 m³	8 h	Texcell (France)	1140-01 C3	
		SARS-CoV-2	99,9% inhibited	45 L	2 h	Texcell (France)	1140-01 A1	
		Bacteriophage ΦX174	99,8% inhibited	Approx. 25 m³	8 h	Japan Food Research Laboratories	13001265005-01	
		Xenotropic murine leukemia virus	99,999% inhibited	45 L	6 h	Charles River Biopharmaceutical Services GmbH	—	
		Coxsackie virus (CA16)	99,9%inhibited	30 m³	4 h	China Electronic Product Reliability and Environmental Testing Research Institute	J2002WT8888-00439	
		Bacteriophage	Mark 3	98,81% inhibited	Approx. 139,3 m³	4 h	SGS Inc	SHES210901902584
		MS2 Phage Virus	Mark 3	99,99% inhibited	Approx. 25 m³	2 h	Shokukanen, Inc.	227131N
	Bacteria	Staphylococcus aureus	Mark 1	99,9% inhibited	20 m³	8 h	Danish Technological Institute	868988
	Pollen	Cedar pollen	Mark 3	99%inhibited	Approx. 24 m³	12 h	Panasonic Product Analysis Center	H21YA017-1
		Ambrosia pollen	Mark 1	99,4% inhibited	20 m³	8 h	Danish Technological Institute	868988
	Odours	Cigarette smoke odour	Mark 1	Odour intensity reduced by 2,4 levels	Approx. 23 m³	0,2 h	Panasonic Product Analysis Center	4AA33-160615-N04
			Mark 3	Odour intensity reduced 1,7 levels	Approx. 139,3 m³	0,5 h	SGS Inc	SHES210901902478

### Licensed in VDI 6022

Certification of a HVAC system under VDI 6022 guarantees that the system fulfills the market's strictest hygiene requirements.



#### VDI 6022 – Part 5 <sup>1)</sup> Certification.

##### Avoidance of allergenic exposure.

Inhibits a wide range of harmful bacteria, viruses, mould, pollen and allergens.



#### VDI 6022 – Part 1 <sup>1)</sup> & 1.1 <sup>2)</sup> Certification.

##### Ventilation and indoor-air quality.

Panasonic nanoe™ X technology improving indoor air quality.

1) Certification mark only valid for nanoe X Generator Mark 3. 2) Certification mark only valid for nanoe X Generator Mark 2 and Mark 3.

## nanoe™ X: improving protection 24/7



Acts to clean your air, so that the indoor environment can be a cleaner and more pleasant place to be all day long. nanoe™ X works together with heating or cooling function when you are at home and can work independently when you are away.

Give the air conditioning the strength to increase the protection at home with nanoe™ X technology and convenient control via the Panasonic Comfort Cloud App.

#### Cleans the air when you are away.

Leave the nanoe™ mode ON to inhibit certain pollutants and deodorise before you return home.

#### Improves your environment when you are at home.

Enjoy a cleaner, comfortable space with loved ones.



### Panasonic Heating & Cooling Solutions is incorporating nanoe™ technology in a wide range of equipment



**Wall-mounted Etherea.**  
**Built-in nanoe X Generator Mark 3.**



**Wall-mounted TZ super-compact.**  
**Built-in nanoe X Generator Mark 1.**



**Floor console.**  
**Built-in nanoe X Generator Mark 1.**



**Wall-mounted Heatcharge VZ.**  
**Built-in nanoe™.**

## Etherea with nanoe™ X technology

A smart solution to keep your home clean, comfortable and welcoming. The smart, Etherea comes with nanoe™ X technology with the benefits of hydroxyl radicals. With advanced control options, class-leading performance, a stylish design and intelligent features, Etherea is designed to make your home comfortable, clean and the ideal place to be.

—ETHEREA—

Available in 3 colors





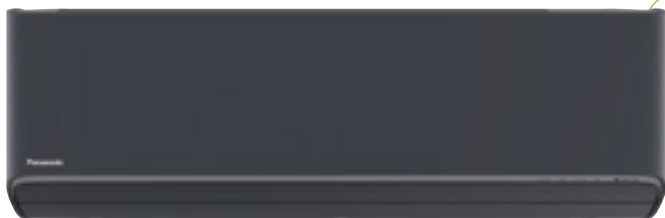

Built-in nanoe X Generator Mark 3



BUILT-IN WI-FI

### 1 Air quality

- nanoe™ X technology with the benefits of hydroxyl radicals (Generator Mark 3)
- Acts to clean your air, so that the indoor environment can be a cleaner and more pleasant place to be all day long
- Cleaning and drying the indoor unit with nanoe™ X

### 2 Smart control

- Built-in Wi-Fi, now with easier and faster set-up
- Advanced smartphone control
- Compatible with Google Assistant and Amazon Alexa

### 3 High efficiency

- Top class energy efficiency up to A+++ in heating and cooling

### 4 Ultimate comfort

- Aerowings 2.0, end-to-end vanes enhance comfortable air flow
- Super Quiet ambient

### 5 Design

- Stylish, monolithic design available in graphite grey, silver and matt white
- Chassis and parts designed for easier installation and servicing
- High class, easy-to-use remote control with backlight



### nanoe™ X: Bringing nature's balance indoors

Etherea comes with nanoe X Generator Mark 3, the latest of the continuously evolving nanoe™ X technology. It has the largest amount of hydroxyl radicals in the history of nanoe™ - 48 trillion hydroxyl radicals per second, 100 times more than the traditional nanoe™. The increased number of hydroxyl radicals, which are the key to nanoe™ power, results in a higher level of performance.

Comparison of time required to inhibit 99% of cedar pollen.

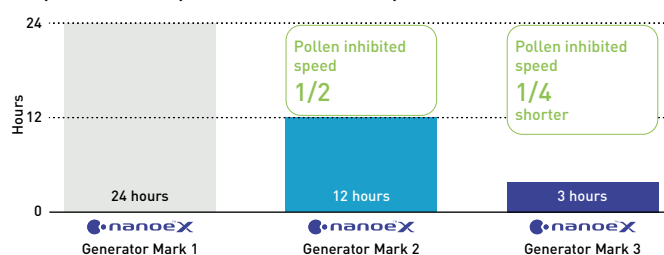

### Technology for the ultimate comfort

#### Introducing the Aerowings 2.0 to the Etherea range.

Panasonic's Aerowings technology consists of two independent flexible vanes that concentrate air flow to heat or cool a room in the shortest time possible and helps distribute air evenly throughout a room.

Thanks to the larger sub vane (72 mm), which is more than doubled in size than other conventional designs, the ability to lift air flow has been further improved.

Aerowings 2.0 has a shower cooling feature which allows air flow to be concentrated evenly towards the ceiling to achieve comfortable cooling across a room, showering gently down into a room rather than one area subject to a continuous icy blast.

For heating, Aerowings 2.0 releases a concentrated air flow downwards to achieve an effect similar to floor heating the air, which rises and fills the room.

### Inside cleaning

The inside cleaning operation acts to clean the inside of indoor unit. It uses nanoe™ X technology that can inhibit certain adhered bacteria, viruses, and mould on the filter, evaporator and air outlet and filter up to 99%. Cross flow fan is coated to prevent dust adhered on its surfaces and can be effective against certain bacteria and mould.



Without coating: Adhered dust.



With anti-static coating: Maintain cleanliness.

Proven prevents dust adhered 62,5%\* compare with non-coating.

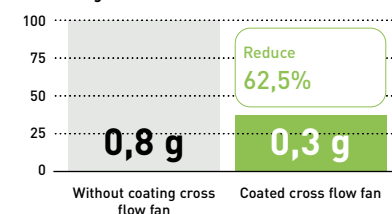

The amount of dust or mould may change depending on the usage frequency and environment.  
\* Based on Panasonic internal testing result.

## Heatcharge. Energy Charge System

heatcharge

Energy class A+++ and offers maximum comfort and energy savings. This powerful air heat pump is designed for commercial and residential climate that places extremely high demands on the heating system.





### 1 Powerful, reliable heating even at low ambient winter temperatures

When the air conditioner is operating, the compressor, which is the power supply of the unit, generates heat. Until now, this heat was released into the atmosphere. Panasonic has utilised this waste heat!

#### Constant heating.

Using stored heat provides stable heating with less drop in temperature. Even when heating operation stops during defrost operation, stored heat continues to constantly warm the room. This eliminates the previous discomfort due to the temperature dropping when heating temporarily stops to ensure stable air conditioner heating.

### 2 Panasonic's full line-up of A+++ heat pumps

In response to the Kyoto Protocol, the European Union set some challenging targets for the reduction in greenhouse-gas emissions. By the year 2020, across the member states, the EU wants to have achieved the following objectives:

- A 20% cut in greenhouse gas emissions (from 1990 base levels)
- The share of renewables in the energy mix to increase by 20%
- An overall reduction of 20% in energy consumption

### 3 Comfort and efficiency

- nanoe™ technology with the benefits of hydroxyl radicals
- Higher efficiency and comfort with Econavi sunlight detection and human activity detection
- Powerful air flow to quickly reach the desired temperature

#### Conventional. The room gradually becomes cold.

Defrost operation: About 11 to 15 min. Fall in room temperature: About 5 to 6 °C.

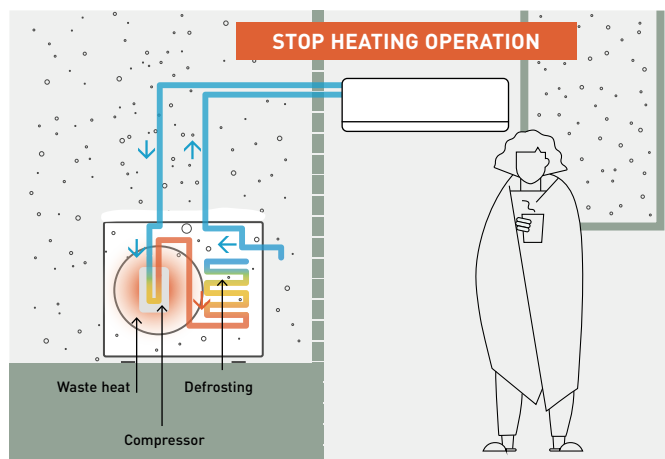

#### Heatcharge. The room is thoroughly warmed.

Defrost operation: About 5 to 6 min. Fall in room temperature: About 1 to 2 °C.

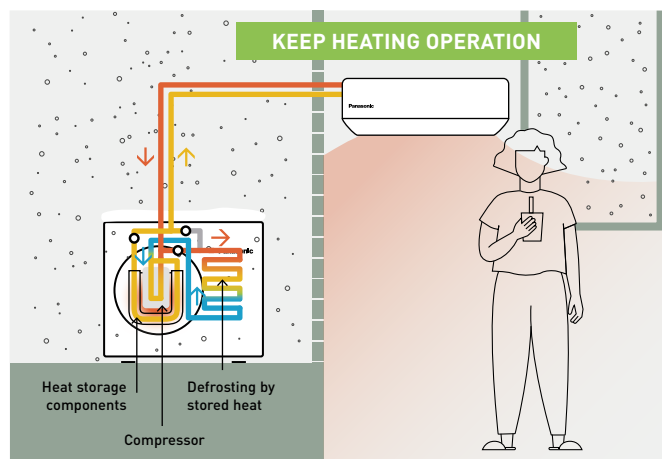

#### Conventional.

During operation, heat is generated inside the compressor.

Compressor

Heat was released into the atmosphere

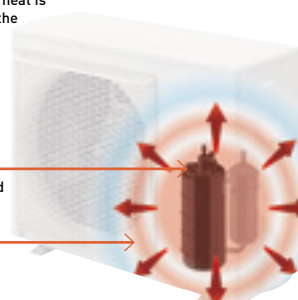

#### Heatcharge.

Heat generated by the compressor is stored inside and used to warm the refrigerant to efficiently increase heating power.

Waste heat is "charged" and used effectively



#### Heatcharge.

The compressor is wrapped and exhaust heat is used for charging.

Heatcharge tank. Waste heat from the compressor is stored.

Finless heat exchanger. Stored heat is converted to energy.

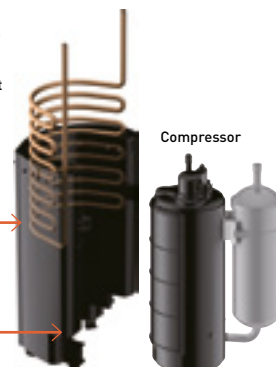

\* Defrost operation time and how low room temperature falls differ depending on the environment in which the unit is being used (how insulated and airtight the room is), operation conditions, and temperature conditions. Output air temperature falls during defrost operation. How low room temperature falls differs depending on the environment in which the unit is being used (how insulated and airtight the room is), operation conditions, and temperature conditions. In environments where a lot of frost accumulates, heating may stop during defrost operation.

## Wall-mounted TZ super-compact with nanoe™ X

Smart comfort and cleaner air in a compact unit.

TZ features nanoe™ X technology with the benefits of hydroxyl radicals for a cleaner and more comfortable indoor environment.



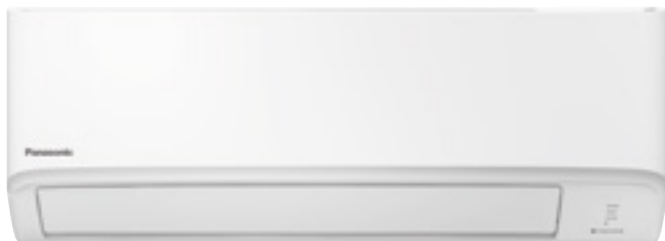

• nanoe™ X



BUILT-IN WI-FI

## 1 Air quality

- nanoe™ X technology with the benefits of hydroxyl radicals
- Acts to clean your air, so that the indoor environment can be a cleaner and more pleasant place to be all day long

## 2 Smart control

- Built-in Wi-Fi, now with easier and faster set-up
- Advanced smartphone control
- Compatible with Google Assistant and Amazon Alexa

## 3 Ultimate comfort

- Aerowings to control air draft direction
- Super Quiet ambient

## 4 Design

- Super-compact design, just 779 mm wide
- Chassis and parts designed for easier installation and servicing
- High class, easy-to-use remote control with backlight

### nanoe™ X: Bringing nature's balance indoors

Panasonic's nanoe™ X technology brings nature's detergent – hydroxyl radicals – indoors to help improve protection 24/7 against several types of pollutants can be inhibited such as certain types of bacteria, viruses, mould, allergens, pollen or hazardous substances.

The nanoe™ X performance varies depending on the room size, environment and usage and it may take several hours to reach the full effect (see page 7 for more detail). nanoe™ X is not medical device, local regulations on building design and sanitary recommendations must be followed.



### Super-compact design

The compact design of the indoor units have a width of just 779 mm. This allows for more installation possibilities, including the limited space above a door.

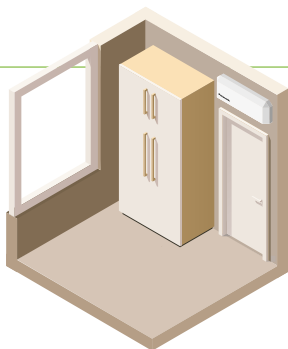

The easy-to-use remote controller features an ergonomic design with tapered rear housing for the most comfortable grip. The controller's intuitive design provides easy operation with five quick access keys for convenient use. The controller also has a minimalist design with the less frequently used keys concealed under a sliding cover.



### Aerowings

Panasonic's Aerowings feature incorporates two blades that concentrate air flow to cool you down in the shortest time possible. This also helps distribute cool air evenly throughout the room.

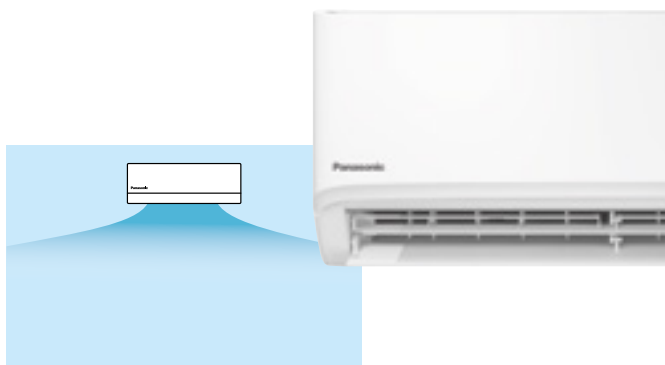

### Comfort that goes on and on with Shower Cooling.

When the Aerowings twin blades direct air towards the ceiling they create the Shower Cooling effect. This ensures cool air is evenly distributed throughout the room and you can stay comfortable without experiencing continuous direct cooling.

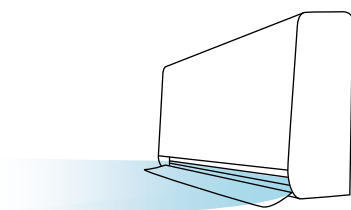

Panasonic Air Conditioners with Aerowings feature an indoor design with wider intake grille and super-high fan speed to produce bigger air flow.

## Wall-mounted indoor units, designed for simple installation and maintenance

The full range of wall-mounted indoor units has been carefully designed for simple, stress-free installation and ongoing maintenance.

\* Not applicable to VZ.





Feature available in Etherea, TZ, BZ, and UZ

## 1 Simple installation

Thanks to advanced improvements, installation time has been dramatically decreased. The models have been designed to provide more stability and strength for neat installation, with newly built-in support and convenient access to the drain hose, cabling inserts and larger space for secure installation.

## 2 Easy maintenance

Meticulously designed for both installer and user benefit, the unit features an easy to remove front grille for convenient access to the interior. The inner workings of the unit have also been redesigned to make maintenance quicker and easier. Electronics and wiring components are now on just one side of the unit to simplify maintenance.



### 1. Stronger installation plate.

The models feature a stronger, solid installation plate that provides more stability and strength. For uneven surfaces, there are 2 additional screws to ensure a neat and secure installation .

Installation plate: Strong and solid.

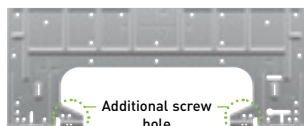

Screw holder for uneven surface (screws not provided).



### 2. One-piece front grille.

The model comes with a one-piece front grille design to make servicing easier. First, open the intake grille and remove the screws. Next, slide the three slider locks and remove the front grille.

One-piece front grille: Easy removal.

Slider locks: Easy to unlock / lock.



### 3. Built-in support holder.

The model features a built-in support holder, making installation easier and providing convenience and workspace improvements.

Convenient installation and serviceability.



### 4. Easy access to drain hose and piping connection.

With larger piping space, pipes and insulations are securely and neatly hidden.

With the visible piping storage, pipes can easily be inspected for leaks without lifting the unit.

Piping storage: up to 15% larger (for TZ-ZKE).

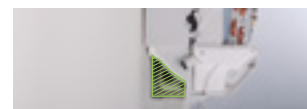

Bigger working space.

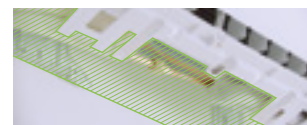

### 5. Easy wire insertion and tightening.

The models have combined 2 wire inserts into 1, ensuring front visibility and convenience while inserting wires from the back.

Single tunnel: easy wire insert.

Bigger working space for wiring connection.



### 6. Easy removal of PCB.

PCB removal is achieved in just 4 easy steps. Simply remove the control board cover, disconnect all connectors from the indicator, disconnect all connectors and pull out the main PCB.

Simple steps for PCB removal.



### 7. Easy / hidden installation of the Wi-Fi adapter.

The latest model features a dedicated space for a network adapter. Easy to plug in, the guided wire slots allow for clear, easy installation and can be neatly tucked away - simple and out of sight!

\* Only for models without built-in network adapter.



### 8. Cross flow fan removal.

The models are carefully designed to make removal of cross flow fans easier compared to the previous models, saving valuable time.

Bigger diameter: up to Ø105 (for Z-ZKE).

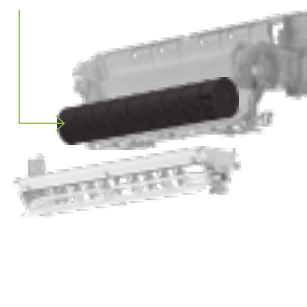

## Floor console. Efficient comfort and clean air all year round

Floor console with nanoe™ X technology: outstanding efficiency A++, comfort (Super Quiet technology only 20 dB(A)) and better air quality combined in a breakthrough design.







The iF Product Design Awards are among the most prestigious awards for product design excellence. Winning the award thanks to its highly intelligent functionality, the Panasonic Floor console is the ideal air-conditioning system for domestic and commercial applications.

**1 nanoe™ X: Bringing nature's balance indoors**  
 Panasonic's nanoe™ X technology brings nature's detergent – hydroxyl radicals – indoors to help improve protection 24/7 against several types of pollutants can be inhibited such as certain types of bacteria, viruses, mould, allergens, pollen or hazardous substances.

The nanoe™ X performance varies depending on the room size, environment and usage and it may take several hours to reach the full effect (see page 7 for more detail). nanoe™ X is not medical device, local regulations on building design and sanitary recommendations must be followed.

**2 Super Quiet operation**  
 When the system reaches its set temperature, the unit will operate at only 20 dB(A). Creating a comfortable home is not only by temperature - a quiet atmosphere is also important.

**3 Designed to follow the high European demands**  
 Super Quiet operation, highly efficient and technology to help clean the air.

**Double air flow for improved comfort and temperature dispersion: through the top for an efficient operation**

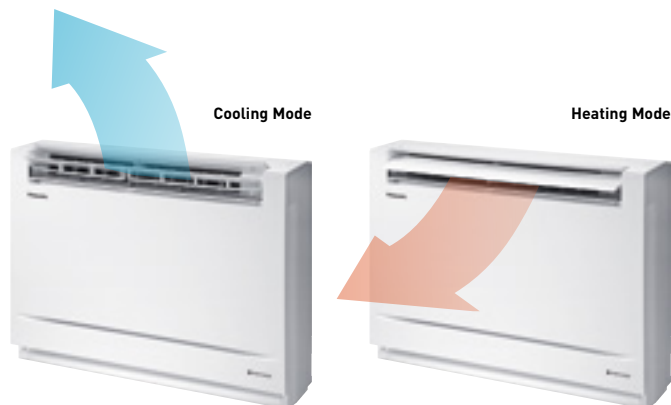

**Stylish infrared control**

Enjoy innovative design at your fingertips with the stylish and sleek Backlit Sky Controller. Bigger screen and easier to use.



**Easy to integrate into your home**

A breakthrough design that integrates perfectly with any style. We have carefully selected materials and processes to create an elegant design. Compact in size and with a stylish design, the floor console will easily integrate into your home's interior decoration. There are four options available:

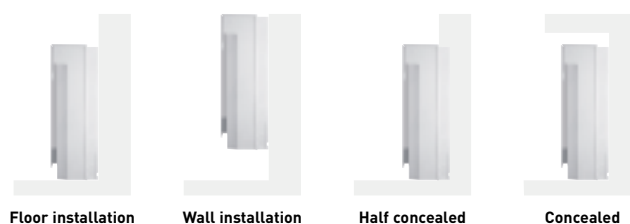

**High energy efficiency class A++**

The floor console brings the outdoor heat energy inside. Can provide heat inside even when it is -15 °C outside.

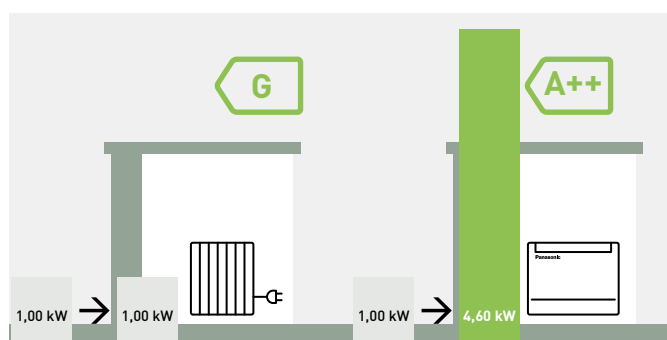

\* SCOP on heating mode for Floor console Type KIT-Z25-UFE and KIT-Z35-UFE compared with electrical heaters at +7 °C.

**The perfect solution for the replacement of old boiler heating systems**



## New Power Heat Multi system

Powerful heating and cleaner indoor air from a single outdoor unit.

The multi split system engineered for cold climates.



Powerful heating of two or three rooms with one outdoor unit, even at  $-25\text{ }^{\circ}\text{C}$  low outdoor temperatures.

The multi split solution offers high flexibility, as 2 to 3 indoor units can be connected to a single outdoor unit.

## POWER HEAT

Reliable heating for the coldest winters.

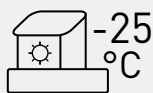

Reliable heating even at  $-25\text{ }^{\circ}\text{C}$ .



Equipped with base pan heater.

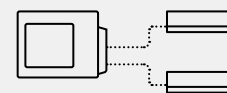

Compatible with Etherea indoor units, with nanoe™ X.

Reduces the burden of aesthetics, installation and maintenance.

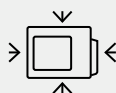

Seamless integration of outdoor unit.

Reduced outdoor unit space, harmonizing with building architecture.



Reduced installation time.

Faster piping connection and pump-down time.



Excellent maintainability.

Advantageous under harsh conditions.

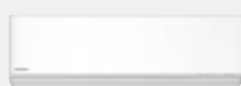

Etherea



### **$-25\text{ }^{\circ}\text{C}$ outdoor temperature operation and base pan heater.**

The heater prevents the outdoor unit base pan from freezing and ensures stable operation even in extremely cold regions.

### **Heating capacity at $-25\text{ }^{\circ}\text{C}$ outdoor temperature: 3,90 kW for the 2-room model and 4,30 kW for the 3-room model.**

Efficiently heats 2 or 3 rooms using a single outdoor unit, even in low outdoor temperatures.

### **High efficiency SCOP 4,60 A++.**

High heating efficiency contributes to environmental protection while reducing electricity bills.

### **Dark color outdoor unit.**

First outdoor unit in dark color, blending seamlessly with home exteriors without compromising aesthetics.

### **Connectable to Etherea indoor units.**

Comfort and convenience with nanoe™ X and built-in Wi-Fi, combined with excellent heating and cooling performance.

### **Shorter installation time (faster than two single units).**

Requires shorter installation times compared to installing multiple single units, reducing the installer's workload.

## Panasonic R2 rotary compressor

The secret is flexibility. Panasonic Inverter air conditioners have the flexibility to vary the rotation speed of the compressor. This allows it to use less energy to maintain the set temperature while also being able to cool the room quicker at start up.

So you can enjoy better savings on your electricity bills while maintaining cooling comfort.



R2 rotary compressors utilize rolling piston technology. The R2 compressor has been tested in extreme conditions: higher efficiency, single and dual piston, R32 / R410A refrigerant, compact size.

## Making the world a cooler place since 1978.

Panasonic rotary compressors for room air conditioners have been installed in the most demanding environments around the world. Designed to withstand extreme conditions, Panasonic Rotary delivers high performance, efficiency and reliable service, no matter where you are. Panasonic, the world's largest manufacturer of rotary compressors.

### Why is the Panasonic R2 rotary compressor so efficient?

1. High efficiency motor. The premium silicon steel motor meets industry efficiency requirements.
2. Improved lubrication of high volume oil pump. The extended, high volume oil pump in conjunction with a larger capacity oil reservoir provides superior lubrication.
3. Accumulator has larger refrigerant capacity. The larger accumulator accommodates generous refrigerant amounts needed in longer line length installations.



\* This image is for 5,0 / 7,1 kW.

## R2 compressor value

### About R2 compressor.

Built upon 36 years of compressor design and production experience, R2 is the next generation of rotary compressors for residential central air conditioning. The technology improvements, enhanced materials and simple design ensure R2 compressors are reliable, efficient and quiet. The R2 compressor delivers quality, comfort and peace of mind in homes around the world. Panasonic's Rotary Compressors have been life tested in some of the world's most demanding environments and the R2 design is the compressor of choice by contractors and homeowners in these challenging climates. For the high performance that home-owners demand, R2 rotary compressors are considered by the industry experts.

### Leading technology.

Used in over 80% of cooling solutions globally, rotary is the world's dominant residential air conditioning compression technology. Panasonic is the leading rotary and residential AC compressor manufacturer in the world, with over 200 million compressors produced.

### Benefits.

Central air conditioning delivered with a Panasonic R2 rotary compressor ensures a superior level of comfort at an economical cost.

## Inverter technology

### Great energy-saving performance. Reduces electricity consumption.

Panasonic Inverter air conditioners are designed to give you exceptional energy savings and performance. At the start up of an air conditioner's operation, a boost in power is required to reach the set temperature. After the set temperature is reached, less power is required to maintain it. The Panasonic Inverter air conditioner varies the rotation speed of the compressor. This provides a highly precise method of maintaining the set temperature.

### Constant comfort.

Precise temperature control with a wide power output range enables an Inverter air conditioner to meet different room occupancy levels – thus ensuring constant comfort.

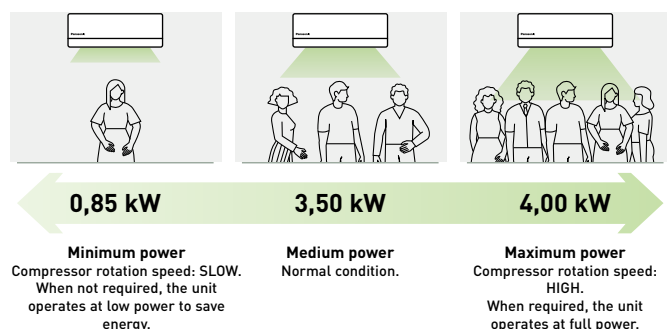

\* Graph shows the 3,5 kW Inverter model's wide power output range during cooling.

### Quick comfort.

Panasonic Inverter air conditioners can operate with higher power during the start up period to cool the room 1,5 times faster and heat the room 4 times faster than non-Inverter models.

#### Comparison of cooling speed.

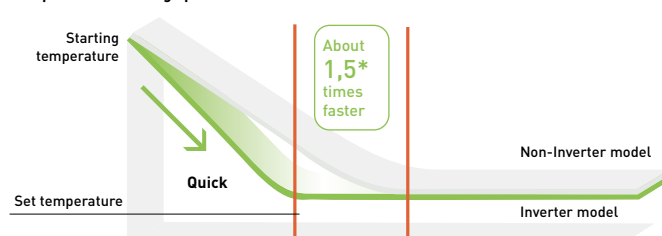

\* Comparison of 3,5 kW Inverter vs. non-Inverter. Outside room temperature: 35 °C; setting temperature: 25 °C.

#### Comparison of heating speed.

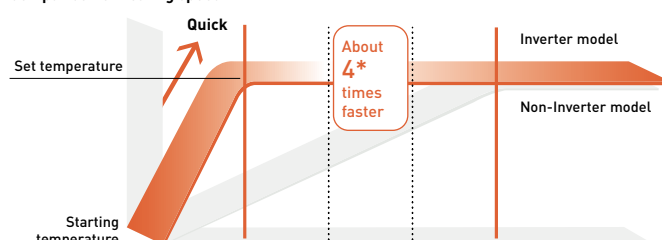

\* Comparison of 2,5 kW Inverter vs. non-Inverter. Outside room temperature: 2 °C ; setting temperature: 25 °C.

## R22 Renewal. Panasonic standard units can be installed on existing R22 pipings

Change your old air conditioning system to a more efficient system!



## An important drive to further reduce the potential damage to our ozone

- All Panasonic standard SKE, TKE and UKE units can be installed on existing R22 pipings
- No need for additional accessories (only pipe reductions)
- Approximately 30% energy savings compared to R22 units

### Panasonic is doing its part

We at Panasonic are also doing our part – recognising that all finances are under pressure at the moment. Panasonic has developed a clean and cost effective solution to enable this latest legislation to be introduced with as minimum an effect on businesses and cash reserves as possible.

The Panasonic renewal system allows good quality existing R22 pipe work to be re-used whilst installing new high efficiency R410A / R32 systems.

By bringing a simple solution to the problem Panasonic can renew all Split Systems and PACi systems; and depending upon certain restrictions we don't even limit the manufacturer's equipment we are replacing.

By installing a new high efficiency Panasonic R410A / R32 system you can benefit from around 30% running cost saving compared to the R22 system.

Yes...

1. Check the capacity of the system you wish to replace
2. Select from the Panasonic range the best system to replace it with
3. Follow the procedure detailed in the brochure and technical data

Simple...

R22 - The reduction of Chlorine critical for a cleaner future.



### Guidance on re-using existing R22 piping for a new R410A / R32 installation

#### 1. Precaution.

The existing R22 piping can be re-used for a R410A / R32 system installation if the following conditions are met and the piping are finally verified to be:

- Dry (no moisture remaining in the piping)
- Clean (no dust remaining in the piping)
- Tight (no refrigerant leak at the joining and piping)

#### 2. Conditions.

- Recover the refrigerant and oil.  
Operate "force cooling" according to the recommended operation time, regardless of the piping length. Single split: 10 min. Multi split: 30 min. After that, carry out "pump down" to recover the refrigerant and oil from the existing R22 system

\* Note: If pump down operation is not possible due to the malfunction of the system, flush and wash the existing piping to collect back the oil and dirt inside the system.

- Check the oil condition. If the oil contains dirt, wash the existing pipes
- Check the oil colour. After pump down, use a cotton bud to wipe the oil from the existing pipe. If the oil colour is higher than ASTM3, use a new pipe as re-use of old piping is not allowed
- Check pipe thickness. Make sure that the pipe thickness is more than 0,8 mm. If the thickness is less than 0,8 mm, use a new pipe
- Rework the flare for R410A / R32 connection. Do not reuse the old flare nuts

Deterioration criteria for refrigerant oil.

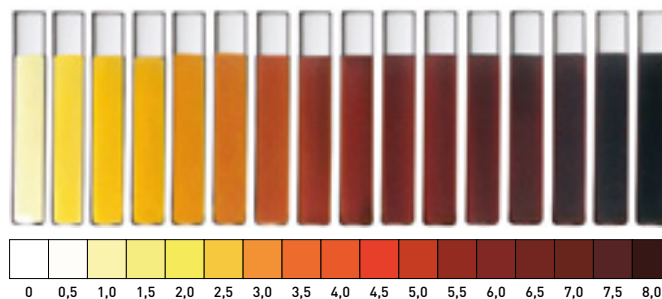

Make sure to use the new flare nuts attached to the R410A / R32 system.

\* Note: If the existing piping size is 1/4" (6,35 mm) and 1/2" (12,7 mm), and the new R410A / R32 system is 1/4" (6,35 mm) and 3/8" (9,52 mm), use a pipe reducer connected at indoor and outdoor unit.

#### 3. Applicable model.

Panasonic single split room air conditioner from CS/ CU-RE/UE/YE/XE/CE/NE/E\*NKE and PKE series onwards.  
Panasonic multi split room air conditioner from CU-2E/3E/4E/5PBE series onwards.

		Liquid		1/4 (6,35)	
		Gas	3/8 (9,52)	1/2 (12,70)	5/8 (15,88)
Split	16 / 20 / 25 / 35	1,6 - 3,5 kW	✓	▲	✗
	42 / 50 / 60	4,2 - 6,0 kW	✗	✓	▲
	71	6,8 - 7,5 kW	✗	✗	✓

✓ Standard piping connection with current piping length and refrigerant charge rules.

▲ This combinations is allowed respecting maximum piping length and refrigerant charged declared in model installed as new.

✗ This combinations is not allowed as it is out of piping diameter.

# Welcome to the connected world of Panasonic Comfort Cloud App



Whether you are at home or at work, the Panasonic Comfort Cloud App puts total control of your indoor air quality at your fingertips.



**nanoe™ X: improving protection 24/7.**



**Monitor energy consumption.**



**Remote control.**



**Pre-heat or cool spaces.**



**Weekly timer.**



**Error notifications.**



**Voice Control.**

## nanoe™ X: improving protection 24/7



Panasonic Comfort Cloud App allows you to see the nanoe™ X coverage in your space through a simulation.



Turn nanoe™ X on easily with “One-touch nanoe™ button” on the main screen.



Select the room shape and size and the unit installation position.



Observe the simulation of nanoe™ X concentration over time!

See page 6 for more detail.



### Monitor energy consumption.

Check the energy consumption of each unit at different time intervals to maximise energy savings and further reduce operation costs.

The electricity tariff can be set by the user and the app will provide the estimated electricity bill for the heat pump.

\*Electricity bill and energy consumption are estimated values. Actual usage may vary. For the multi split air conditioner, electricity bill and energy consumption will be the same for all indoor units.

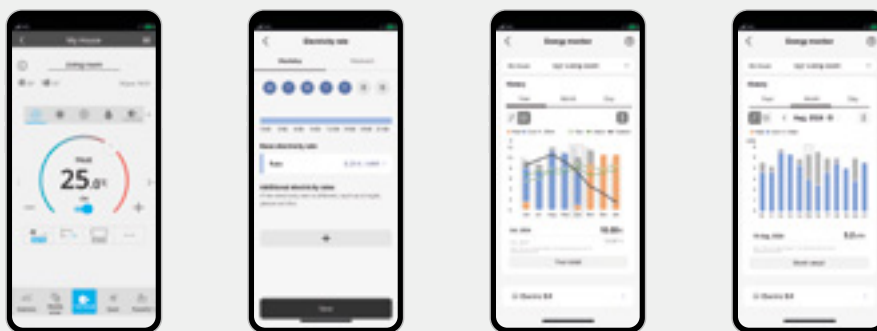

The Panasonic Comfort Cloud Application enables you to conveniently manage and monitor multiple air conditioning units for homes from just one mobile device. Also, energy monitoring is possible allowing opportunity to learn how to reduce the operating cost even more.

- Connectable up to 200 units\* with just 1 device
- Compatible for both residential and commercial applications

\* 10 different groups, with up to 20 units / per group.



### Easier setup with advanced built-in Wi-Fi

The advanced built-in Wi-Fi setup enables secured and easier connection to Panasonic Comfort Cloud App by scanning the QR code\*.

\*Feature available only in CS-XZ\*\*ZKEW-H, CS-XZ\*\*ZKEW, CS-MZ16ZKE, CS-Z\*\*ZKEW, CS-MTZ16ZKE and CS-TZ\*\*ZKEW.

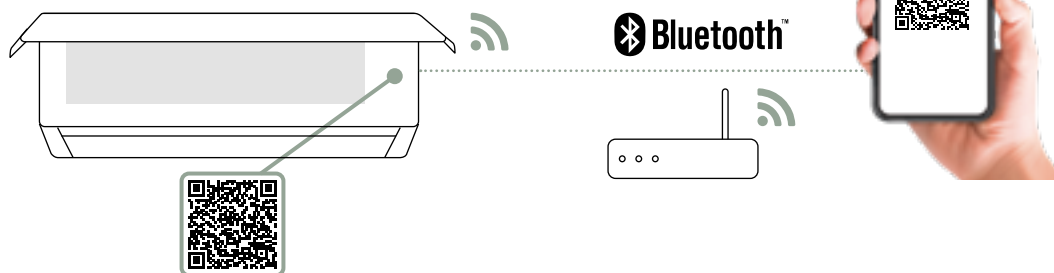

Scan the QR code to enable easier Wi-Fi connectivity to the air conditioner.

### Requirements for connecting with Panasonic Comfort Cloud App



#### Indoor unit with built-in Wi-Fi:

CS-XZ\*\*ZKEW-H, CS-XZ\*\*ZKEW, CS-MZ16ZKE, CS-Z\*\*ZKEW, CS-MTZ16ZKE, CS-TZ\*\*ZKEW and CS-Z\*\*YKEA-1.

Remark: indoor temperature display and some special functions are not available through the app for all models. Languages: Available in 20 European languages: Bulgarian, Croatian, Czech, Danish, Deutsch, English, Estonian, Finnish, French, Greek, Hungarian, Italian, Norwegian, Polish, Portuguese, Slovenian, Spanish, Swedish, Turkish and Lithuanian.



#### Indoor unit with optional CZ-TACG1 Wi-Fi adapter:

CS-VZ\*\*SKE, CS-BZ\*\*ZKE, CZ-UZ\*\*ZKE, CS-MZ20UFEA, CS-Z\*\*UFEAW, CS-MZ20UD3EA and CS-Z\*\*UD3EAW

#### Indoor unit with optional CZ-CAPWFC2 Wi-Fi adapter or CONEX remote controller:

S-M20PY3E and S-\*\*PY3E.

#### Download free app: Panasonic Comfort Cloud App.

Other hardware requirements: Router and Internet (purchase and subscribe separately). Built-in Wi-Fi in certain models or with optional adaptor CZ-TACG1 connected to port CN-CNT. Panasonic Cloud Server is designed, operated and managed by Panasonic.



# Voice Control. Words do more than actions

Boundless control and hands-free help to access all the features of your air-to-air heat pump. Maximising your comfort is now a breeze with our connected air conditioners using the Panasonic Comfort Cloud App and voice control.



## Seamless set up in 3 simple steps

Set up your Panasonic Comfort Cloud App.



Set up your Google Nest Mini or Amazon Echo devices and app.



Link your Google Nest Mini or Amazon Echo with Panasonic Comfort Cloud App.



### Compatible devices as of July 2024:

1. Android™ 8.1 or above
2. iOS 14.7 or above

**Please note:**

- This is not a definitive list of all compatible devices, other similar devices which use supported Operating Systems should also work either via dedicated apps. Please note that user experience may vary slightly depending on hardware and software combination
- Google, Android™, Google Play and Google Home are trademarks of Google LLC.
- Google Assistant is not available in certain languages and countries
- Amazon, Alexa and all related logos are trademarks of Amazon.com, Inc. or its affiliates
- Availability of Voice Assistant services varies depending on country and language
- Google Assistant and Alexa are compatible with the models shown in pages 30 and 31.



### Turn ON / OFF air conditioner

#### Convenient control for blissful rest.

Turn ON / OFF AC with ease when preparing a comfortable space for your little ones.

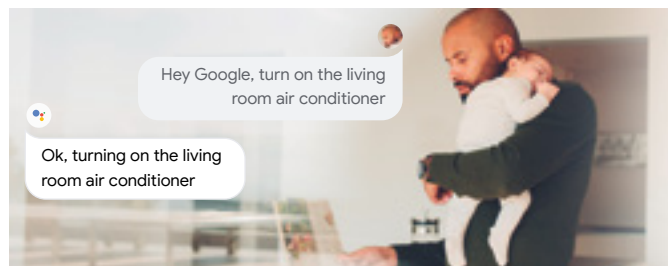

### Adjust temperature

#### Easy control for uninterrupted quality time.

Adjust AC temperature to your comfort with a simple voice command.

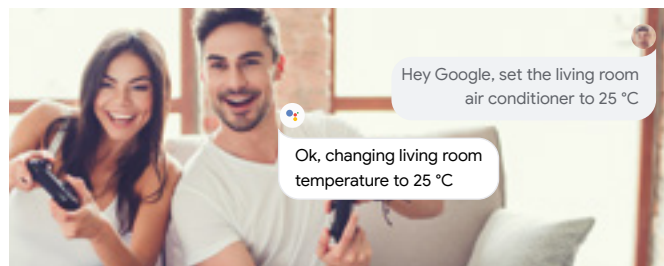

### Change mode

#### Extra help when you have a hectic day.

Conveniently change your AC operation mode to cool / heat / auto when your hands are full.



### Check current status

#### Hands-free comfort for the whole family.

Easy access for the elderly to check current AC operation status and adjust AC settings.



### Get multiple things done with your voice

Simplify your day with your personalised routine by grouping individual actions.

#### Schedule your routine with your voice.

With the routine function, you can customise voice commands and control multiple voice-controlled devices including our network-enabled air conditioners to help you with your personalised routine.

Find out more (Amazon): <https://www.techhive.com/article/3327501/how-to-use-alexa-routines.html>

#### Example of morning routine.

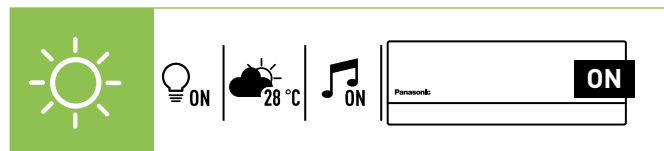

#### Example of night routine.

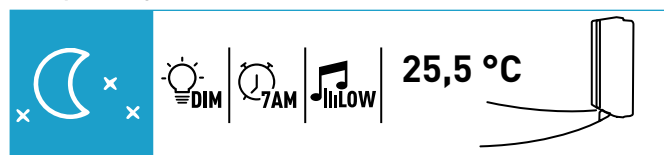

### Voice Control with Network-Enabled air conditioners

Functions	When you are home		When away from home
	Remote control	Voice Control	Panasonic Comfort Cloud App
Smart control	Power ON / OFF	✓	✓
	Control multiple units in 1 location	—	✓
	Control multiple units in multiple locations	—	✓
	Set up and manage routines	—	—
Smart comfort	Cooling mode	✓	✓
	Heating mode	✓	✓
	Auto mode	✓	✓
	nanoe™ X mode	✓	✓
	Inside cleaning	✓	✓
	Summer House mode	✓	✓
	Pre-cool	—	✓
Smart efficiency	Change temperature	✓	✓
	Analyse energy usage patterns	—	✓
	Compare historical usage	—	✓
	Receive error notifications	—	✓
Smart assist	Assign multiple users	✓	✓
	Check power ON / OFF	✓	✓
	Check temperature settings	✓	✓
	Check room temperature	✓	✓

## Control and connectivity

Panasonic offers its customers cutting-edge technology, specially designed to ensure our air conditioning systems deliver even higher performance.

You can properly manage the air conditioning and perform comprehensive monitoring and control, with all of the features the remote controller provides at home, from anywhere in the world thanks to the internet applications Panasonic has created for you.



### Wi-Fi adapter for smart control via Panasonic Comfort Cloud App

#### **CZ-TACG1. Wi-Fi adaptor (optional)\*.**

- Optional Wi-Fi adaptor for domestic range
- Compact size for easy installation
- Available for built-in or exposed installation depending on model type

\* Functionality varies depending on models. Please contact your local dealers for compatible models.

#### **Specifications.**

- Input voltage: DC 12 V
- Power consumption: Maximum 660 mW
- Size (H x W x D): 66 x 36 x 12 mm
- Mass: Approx. 85 g
- Interface: 1 x Wireless LAN
- Wireless LAN standard: IEEE 802,11 b/g/n
- Frequency range: 2,4GHz band
- Encryption: WPA2-PSK (TKIP/AES)



## Domestic integration to S-Link

### CZ-CAPRA1

Can connect RAC range to S-Link. Full control is now possible.

#### Integrates any unit in big system control.

- YKEA server room integration <sup>1)</sup>
- Small offices with domestic indoors
- Tender for refurbishment (old system Domestic and VRF in one installation)
- Centralized Control Systems: 64 indoor units
- Intelligent controller / Web Server: 256 indoor units
- Panasonic AC Smart Cloud

- Basic operation items: ON / OFF, Mode select, Temperature setting, Fan speed, Flap setting, Remote control prohibit
- External input: ON / OFF control signal, Abnormal stop signal
- External output for Relay <sup>2)</sup>: Operation status (ON / OFF), Alarm status output

1) When duty rotation using the remote controller is set up, CZ-CAPRA1 cannot be connected.  
2) Because current CN-CNT connector can not provide the power for external output relay, additional 12 V DC power supply for external relay is necessary.

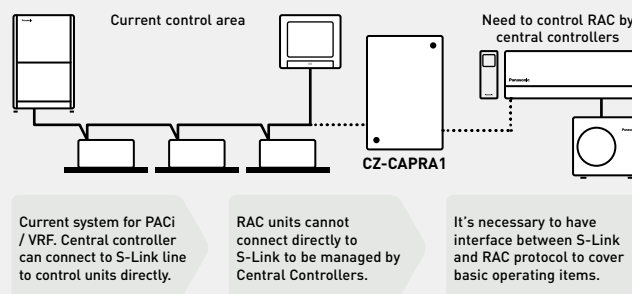

## Control by BMS

### PAW-AC-KNX-1i (Intesis), PAW-AC-MBS-1 (Intesis), PAW-AC-BAC-1 <sup>1)</sup> (Intesis), PAW-AZAC-KNX-1 (Airzone), PAW-AZAC-MBS-1 (Airzone) and PAW-AZAC-BAC-1 (Airzone).

Great flexibility for integration into your KNX, Modbus and BACnet projects allows fully bi-directional monitoring and control of all the functioning parameters.

- Quick Installation
- External power not required
- Direct connection to the unit via CN-CNT connector
- Bidirectional control
- Unit can be controller simultaneously by remote controller and the gateway

1) This interface allows a complete and natural integration of Panasonic air conditioners into either BACnet IP or MS/TP networks. Is a BTL certified device. \* For specific functionality list of each gateway, please check the user's manual.

## Easy connectivity









CN-CNT port easy to access in all indoor units, without dismantling the unit to reach the connector. Can easier connect: Wireless accessory / KNX / Modbus / BACnet / CZ-TACG1 / CZ-CAPRA1 to integrate to PACi control.

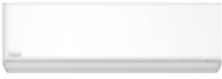

Model name	Interface
CZ-TACG1	Wi-Fi adapter for smart control via Panasonic Comfort Cloud App
CZ-CAPRA1	RAC interface adapter for integration into S-Link, plus external input and alarm/status output
PAW-AC-KNX-1i	KNX interface. Can be used with all models which have a CN-CNT connector (Intesis)
PAW-AC-MBS-1	Modbus interface. Can be used with all models which have a CN-CNT connector (Intesis)
PAW-AC-BAC-1	BACnet interface. Can be used with all models which have a CN-CNT connector (Intesis)

Model name	Interface
PAW-AZAC-KNX-1	KNX interface. Can be used with all models which have a CN-CNT connector (Airzone)
PAW-AZAC-MBS-1	Modbus interface. Can be used with all models which have a CN-CNT connector (Airzone)
PAW-AZAC-BAC-1	BACnet interface. Can be used with all models which have a CN-CNT connector (Airzone)
PAW-AC-DIO	This interface can be used with all models which have a CN-RMT connector

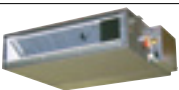
# Domestic air conditioner R32 range

Page	Single split units	2,0 kW	2,5 kW	3,5 kW	4,2 kW	5,0 kW	6,0 kW	7,1 kW
<b>Wall-mounted Heatcharge VZ · R32</b>								
P. 32			CS-VZ9SKE CU-VZ9SKE	CS-VZ12SKE CU-VZ12SKE				
<b>Wall-mounted Etherea · R32</b>								
		CS-XZ20ZKEW-H CU-Z20ZKE	CS-XZ25ZKEW-H CU-Z25ZKE	CS-XZ35ZKEW-H CU-Z35ZKE	CS-XZ42ZKEW-H CU-Z42ZKE			
P. 33		CS-XZ20ZKEW CU-Z20ZKE	CS-XZ25ZKEW CU-Z25ZKE	CS-XZ35ZKEW CU-Z35ZKE		CS-XZ50ZKEW CU-Z50ZKE		
		CS-Z20ZKEW CU-Z20ZKE	CS-Z25ZKEW CU-Z25ZKE	CS-Z35ZKEW CU-Z35ZKE	CS-Z42ZKEW CU-Z42ZKE	CS-Z50ZKEW CU-Z50ZKE		CS-Z71ZKEW CU-Z71ZKE
<b>Wall-mounted TZ super-compact · R32</b>								
P. 34		CS-TZ20ZKEW CU-TZ20ZKE	CS-TZ25ZKEW CU-TZ25ZKE	CS-TZ35ZKEW CU-TZ35ZKE	CS-TZ42ZKEW CU-TZ42ZKE	CS-TZ50ZKEW CU-TZ50ZKE	CS-TZ60ZKEW CU-TZ60ZKE	CS-TZ71ZKEW CU-TZ71ZKE
<b>Wall-mounted BZ super-compact · R32</b>								
P. 35			CS-BZ25ZKE CU-BZ25ZKE	CS-BZ35ZKE CU-BZ35ZKE		CS-BZ50ZKE CU-BZ50ZKE	CS-BZ60ZKE CU-BZ60ZKE	
<b>Wall-mounted UZ super-compact · R32</b>								
P. 36			CS-UZ25ZKE CU-UZ25ZKE	CS-UZ35ZKE CU-UZ35ZKE		CS-UZ50ZKE CU-UZ50ZKE		
<b>Floor console · R32</b>								
P. 37			CS-Z25UFEAW CU-Z25UBEAW	CS-Z35UFEAW CU-Z35UBEAW		CS-Z50UFEAW CU-Z50UBEAW		
<b>Low static pressure hide-away · R32</b>								
P. 38			CS-Z25UD3EAW CU-Z25UBEAW	CS-Z35UD3EAW CU-Z35UBEAW		CS-Z50UD3EAW CU-Z50UBEAW	CS-Z60UD3EAW CU-Z60UBEAW	
<b>Stand-alone units</b>								
<b>NEW RAC Solo · R290 / R32</b>								
P. 47			P-M0G16IC5-E	P-MOZ20IC5-E	P-MOZ25IC5-E		P-MOZ30IC5-E	

Try Panasonic's augmented reality tool, the AR Heat Pump Viewer.

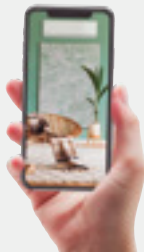

Configure your multi split system in a few steps using our online tool and see all possible combinations.



Page	Multi split indoors	1,6 kW	2,0 kW	2,5 kW	3,5 kW	4,2 kW	5,0 kW	6,0 kW	7,1 kW
<b>Wall-mounted Etherea</b>									
									
			CS-XZ20ZKEW-H	CS-XZ25ZKEW-H	CS-XZ35ZKEW-H	CS-XZ42ZKEW-H			
P. 43			CS-XZ20ZKEW	CS-XZ25ZKEW	CS-XZ35ZKEW		CS-XZ50ZKEW		
		CS-MZ16ZKE	CS-Z20ZKEW	CS-Z25ZKEW	CS-Z35ZKEW	CS-Z42ZKEW	CS-Z50ZKEW		CS-Z71ZKEW
<b>Wall-mounted TZ super-compact</b>									
P. 43		CS-MTZ16ZKE	CS-TZ20ZKEW	CS-TZ25ZKEW	CS-TZ35ZKEW	CS-TZ42ZKEW	CS-TZ50ZKEW	CS-TZ60ZKEW	CS-TZ71ZKEW
<b>Floor console</b>									
P. 43			CS-MZ20UFEA	CS-Z25UFEAW	CS-Z35UFEAW		CS-Z50UFEAW		
<b>4 Way 60x60 cassette</b>									
P. 43			S-M20PY3E CZ-KPY4	S-25PY3E CZ-KPY4	S-36PY3E CZ-KPY4		S-50PY3E CZ-KPY4	S-60PY3E CZ-KPY4	
<b>Low static pressure hide-away</b>									
P. 43			CS-MZ20UD3EA	CS-Z25UD3EAW	CS-Z35UD3EAW		CS-Z50UD3EAW	CS-Z60UD3EAW	
<b>Free Multi outdoors</b>									
		3,2 ~ 6,0 kW	3,2 ~ 6,0 kW	3,2 ~ 7,7 kW	4,5 ~ 9,5 kW	4,5 ~ 11,2 kW	4,5 ~ 11,5 kW	4,5 ~ 14,7 kW	4,5 ~ 18,3 kW
P. 42	<b>Outdoor units Free Multi system Z · R32</b>								
		CU-2Z35TBE	CU-2Z41TBE	CU-2Z50TBE	CU-3Z52TBE	CU-3Z68TBE	CU-4Z68TBE	CU-4Z80TBE	CU-5Z90TBE
<b>Power Heat Multi system</b>									
		5,0 kW (2 room)				7,5 kW (3 room)			
P. 44	<b>NEW Outdoor units Power Heat Multi system · R32</b>								
		CU-2Z50ABEC				CU-3Z75ABEC			
<b>Multi wall TZ outdoors</b>									
		3,2 ~ 6,0 kW			3,2 ~ 7,7 kW		4,5 ~ 9,5 kW		
P. 45	<b>Outdoor units Multi TZ for wall TZ indoors · R32</b>								
		CU-2TZ41TBE			CU-2TZ50TBE		CU-3TZ52TBE		

## Wall-mounted Heatcharge VZ · R32

- Energy Charge System. Heat storage unit which utilizes non-stop heating and fast heating function
- Econavi Sunlight Detection sensor: Even higher efficiency and great comfort
- nanoe™ technology to improve protection 24/7
- Super Quiet! Only 18 dB(A), equivalent to night-time in the countryside
- Performance tested at -35 °C outdoor temperature



nanoe™

Kit			KIT-VZ9-SKE	KIT-VZ12-SKE
Cooling capacity	Nominal (Min - Max)	kW	2,50 [0,60 - 3,00]	3,50 [0,60 - 4,00]
<b>SEER<sup>1)</sup></b>			<b>10,50 A+++</b>	<b>10,00 A+++</b>
Pdesign (cooling)		kW	2,50	3,50
Input power	Nominal (Min - Max)	kW	0,43 [0,14 - 0,61]	0,80 [0,14 - 0,98]
Annual energy consumption <sup>3)</sup>		kWh/a	83	122
Heating capacity	Nominal (Min - Max)	kW	3,60 [0,60 - 7,80]	4,20 [0,60 - 9,20]
COP <sup>2)</sup>		W/W	5,63	5,04
Heating capacity at -7 °C		kW	5,00	5,60
COP at -7 °C <sup>2)</sup>		W/W	2,07	2,00
<b>SCOP<sup>1)</sup></b>			<b>6,20 A+++</b>	<b>5,90 A+++</b>
Pdesign at -10 °C		kW	3,60	4,20
Input power	Nominal (Min - Max)	kW	0,64 [0,14 - 2,72]	0,83 [0,14 - 3,16]
Annual energy consumption <sup>3)</sup>		kWh/a	812	995
<b>Indoor unit</b>			<b>CS-VZ9SKE</b>	<b>CS-VZ12SKE</b>
Power supply		V	230	230
Recommended fuse		A	16	16
Connection indoor / outdoor		mm <sup>2</sup>	4x1,5	4x1,5
Air flow	Cool / Heat (Hi)	m <sup>3</sup> /min	12,5 / 15,5	12,9 / 15,9
Sound pressure <sup>4)</sup>	Cool (Hi / Lo / Q-Lo)	dB(A)	44 / 27 / 18	45 / 33 / 18
	Heat (Hi / Lo / Q-Lo)	dB(A)	44 / 26 / 18	45 / 29 / 18
Dimension	H x W x D	mm	295 x 798 x 375	295 x 798 x 375
Net weight		kg	14,5	14,5
<b>Outdoor unit</b>			<b>CU-VZ9SKE</b>	<b>CU-VZ12SKE</b>
Air flow	Cool / Heat (Hi)	m <sup>3</sup> /min	33,1 / 33,1	35,4 / 33,9
Sound pressure <sup>4)</sup>	Cool / Heat (Hi)	dB(A)	49 / 49	50 / 50
Dimension <sup>5)</sup>	H x W x D	mm	630 x 799 x 299	630 x 799 x 299
Net weight		kg	39,5	39,5
Piping diameter	Liquid	Inch (mm)	1/4 [6,35]	1/4 [6,35]
	Gas	Inch (mm)	3/8 [9,52]	3/8 [9,52]
Pipe length range		m	3 - 15	3 - 15
Elevation difference (in / out)		m	12	12
Pre-charged pipe length		m	7,5	7,5
Additional gas amount		g/m	20	20
Refrigerant (R32) / CO <sub>2</sub> Eq.		kg / T	1,05 / 0,70875	1,10 / 0,7425
Operating range	Cool Min ~ Max	°C	-10 ~ +43	-10 ~ +43
	Heat Min ~ Max	°C	-30 ~ +24	-30 ~ +24
Lowest outdoor temperature tested by 3rd party laboratory <sup>6)</sup>		°C	-35	-35

1) Energy Label Scale from A+++ to D. 2) EER and COP calculation is based in accordance to EN 14511. 3) The annual energy consumption is calculated in accordance to EU/626/2011. 4) The sound pressure of the indoor unit shows the value measured of a position of 1 m in front of the main body and 0,8 m below the unit. For outdoor unit 1 m in front and 1 m in rear side of main body. The sound pressure is measured in accordance with JIS C 9612. Q-Lo: Quiet mode. Lo: The lowest set fan speed. 5) Add 70 mm for piping port. 6) Tested by 3rd party laboratory, SP, according to EN 14511:2013 and SP Method 1721, this temperature is not guaranteed by Factory.

Accessories	
<b>CZ-TACG1</b>	Wi-Fi adapter for smart control via Panasonic Comfort Cloud App

Accessories	
<b>CZ-CAPRA1</b>	RAC interface adapter for integration into S-Link



SEER and SCOP: For KIT-VZ9-SKE. -35 °C HEATING MODE: Heating performance tested at -35 °C by SP, European third party laboratory. INTERNET CONTROL: Optional.



## Wall-mounted Etherea · R32

- nanoe™ X technology to improve protection 24/7
- Stylish, monolithic design available in graphite grey, silver and matt white
- Improved SEER / SCOP for top class energy efficiency
- Aerowings 2.0 for the ultimate comfort
- Easy-to-use remote controller
- Built-in Wi-Fi for smart control via Panasonic Comfort Cloud App
- Compatible with Google Assistant and Amazon Alexa
- Chassis and parts designed for easier installation



Kit graphite grey			KIT-XZ20-ZKE-H	KIT-XZ25-ZKE-H	KIT-XZ35-ZKE-H	KIT-XZ42-ZKE-H	—	—
Kit silver			KIT-XZ20-ZKE	KIT-XZ25-ZKE	KIT-XZ35-ZKE	—	KIT-XZ50-ZKE	—
Kit matt white			KIT-Z20-ZKE	KIT-Z25-ZKE	KIT-Z35-ZKE	KIT-Z42-ZKE	KIT-Z50-ZKE	KIT-Z71-ZKE
Cooling capacity	Nominal (Min - Max)	kW	2,05 (0,75 - 2,65)	2,50 (0,85 - 3,50)	3,50 (0,85 - 4,20)	4,20 (0,85 - 5,00)	5,00 (0,98 - 6,00)	7,10 (0,98 - 8,50)
EER <sup>1)</sup>	Nominal (Min - Max)	W/W	4,66 (4,69 - 4,02)	4,90 (5,00 - 3,89)	4,27 (4,25 - 3,62)	3,39 (3,62 - 3,18)	3,68 (3,92 - 3,16)	3,24 (2,33 - 2,83)
<b>SEER<sup>2)</sup></b>			<b>8,70 A+++</b>	<b>9,50 A+++</b>	<b>9,50 A+++</b>	<b>7,10 A++</b>	<b>8,50 A+++</b>	<b>6,50 A++</b>
Pdesign (cooling)		kW	2,1	2,5	3,5	4,2	5,0	7,1
Input power	Nominal (Min - Max)	kW	0,44 (0,16 - 0,66)	0,51 (0,17 - 0,90)	0,82 (0,20 - 1,16)	1,24 (0,24 - 1,57)	1,36 (0,25 - 1,90)	2,19 (0,42 - 3,00)
Annual energy consumption <sup>3)</sup>		kWh/a	84	92	129	207	206	382
Heating capacity	Nominal (Min - Max)	kW	2,80 (0,75 - 4,00)	3,40 (0,80 - 4,80)	4,00 (0,80 - 5,50)	5,30 (0,80 - 6,80)	5,80 (0,98 - 8,00)	8,20 (0,98 - 10,20)
Heating capacity at -7 °C		kW	2,38	2,8	3,2	4,11	4,8	6,31
COP <sup>1)</sup>	Nominal (Min - Max)	W/W	4,67 (4,69 - 4,26)	4,86 (5,00 - 4,07)	4,55 (4,44 - 3,77)	3,73 (4,21 - 3,66)	4,14 (4,26 - 3,35)	3,73 (2,45 - 3,31)
<b>SCOP<sup>2)</sup></b>			<b>4,80 A++</b>	<b>5,20 A+++</b>	<b>5,20 A+++</b>	<b>4,30 A+</b>	<b>4,80 A++</b>	<b>4,20 A+</b>
Pdesign at -10 °C		kW	2,4	2,6	2,9	3,6	4,2	5,5
Input power	Nominal (Min - Max)	kW	0,60 (0,16 - 0,94)	0,70 (0,16 - 1,18)	0,88 (0,18 - 1,46)	1,42 (0,19 - 1,86)	1,40 (0,23 - 2,39)	2,20 (0,40 - 3,08)
Annual energy consumption <sup>3)</sup>		kWh/a	700	700	781	1172	1225	1833
<b>Indoor unit graphite grey</b>			<b>CS-XZ20ZKEW-H</b>	<b>CS-XZ25ZKEW-H</b>	<b>CS-XZ35ZKEW-H</b>	<b>CS-Z42ZKEW-H</b>	—	—
<b>Indoor unit silver</b>			<b>CS-XZ20ZKEW</b>	<b>CS-XZ25ZKEW</b>	<b>CS-XZ35ZKEW</b>	—	<b>CS-XZ50ZKEW</b>	—
<b>Indoor unit matt white</b>			<b>CS-Z20ZKEW</b>	<b>CS-Z25ZKEW</b>	<b>CS-Z35ZKEW</b>	<b>CS-Z42ZKEW</b>	<b>CS-Z50ZKEW</b>	<b>CS-Z71ZKEW</b>
Power supply	V		230	230	230	230	230	230
Recommended fuse	A		16	16	16	16	16	20
Connection indoor / outdoor	mm <sup>2</sup>		4x1,5	4x1,5	4x1,5	4x1,5	4x2,5	4x2,5
Air flow	Cool / Heat	m <sup>3</sup> /min	10,4/11,9	12,4/13,0	12,7/14,4	14,5/15,4	17,4/19,1	19,0/19,9
Moisture removal volume	L/h		1,3	1,5	2	2,4	2,8	4,1
Sound pressure <sup>4)</sup>	Cool (Hi / Lo / Q-Lo)	dB(A)	35/24/19	39/25/19	42/28/19	43/31/25	44/37/30	47/38/30
	Heat (Hi / Lo / Q-Lo)	dB(A)	36/25/19	39/27/19	43/33/19	43/35/29	44/37/30	47/38/30
Dimension	H x W x D	mm	295 x 870 x 229	295 x 870 x 229	295 x 870 x 229	295 x 870 x 229	295 x 1040 x 244	295 x 1040 x 244
Net weight	kg		10	10	11	10	12	13
nanoe X Generator			Mark 3	Mark 3	Mark 3	Mark 3	Mark 3	Mark 3
<b>Outdoor unit</b>			<b>CU-Z20ZKE</b>	<b>CU-Z25ZKE</b>	<b>CU-Z35ZKE</b>	<b>CU-Z42ZKE</b>	<b>CU-Z50ZKE</b>	<b>CU-Z71ZKE</b>
Air flow	Cool / Heat	m <sup>3</sup> /min	26,5/25,7	28,7/26,5	29,8/29,8	29,8/30,9	39,8/36,9	44,7/45,8
Sound pressure <sup>4)</sup>	Cool / Heat (Hi)	dB(A)	45/46	46/47	48/50	49/51	47/47	52/54
Dimension <sup>5)</sup>	H x W x D	mm	542 x 780 x 289	542 x 780 x 289	542 x 780 x 289	542 x 780 x 289	695 x 875 x 320	695 x 875 x 320
Net weight	kg		27	27	31	31	40	45
Piping diameter	Liquid	Inch (mm)	1/4 (6,35)	1/4 (6,35)	1/4 (6,35)	1/4 (6,35)	1/4 (6,35)	1/4 (6,35)
	Gas	Inch (mm)	3/8 (9,52)	3/8 (9,52)	3/8 (9,52)	1/2 (12,70)	1/2 (12,70)	5/8 (15,88)
Pipe length range	m		3 - 15	3 - 15	3 - 15	3 - 15	3 - 30	3 - 30
Elevation difference (in / out)	m		15	15	15	15	15	20
Pre-charged pipe length	m		7,5	7,5	7,5	7,5	7,5	10
Additional gas amount	g/m		10	10	10	10	15	25
Refrigerant (R32) / CO <sub>2</sub> Eq.	kg / T		0,70/0,47	0,70/0,47	0,81/0,55	0,83/0,56	1,13/0,76	1,35/0,91
Operating range	Cool Min ~ Max	°C	-10 ~ +43	-10 ~ +43	-10 ~ +43	-10 ~ +43	-10 ~ +43	-10 ~ +43
	Heat Min ~ Max	°C	-20 ~ +24	-20 ~ +24	-20 ~ +24	-20 ~ +24	-20 ~ +24	-20 ~ +24

1) EER and COP calculation is based in accordance to EN 14511. 2) Energy Label Scale from A+++ to D. 3) The annual energy consumption is calculated in accordance to EU/626/2011. 4) The sound pressure of the indoor unit shows the value measured of a position of 1 m in front of the main body and 0,8 m below the unit. For outdoor unit 1 m in front and 1 m in rear side of main body. The sound pressure is measured in accordance with JIS C 9612. Q-Lo: Quiet mode. Lo: The lowest set fan speed. 5) Add 70 mm for piping port.

### Accessories

**CZ-CAPRA1** RAC interface adapter for integration into S-Link

### Accessories

**CZ-RD517C** Wired remote controller for wall-mounted and floor console



SEER and SCOP: For KIT-\*\*25-ZKE and KIT-\*\*35-ZKE. SUPER QUIET: For KIT-\*\*20-ZKE, KIT-\*\*25-ZKE and KIT-\*\*35-ZKE. INTERNET CONTROL: Built-in Wi-Fi.

Rating conditions: Cooling indoor 27 °C DB / 19 °C WB. Cooling outdoor 35 °C DB / 24 °C WB. Heating indoor 20 °C DB. Heating outdoor 7 °C DB / 6 °C WB. (DB: Dry Bulb; WB: Wet Bulb). Specifications subject to change without notice. For detailed information about ErP / Energy Labelling, please visit our websites [www.aircon.panasonic.eu](http://www.aircon.panasonic.eu) or [www.ptc.panasonic.eu](http://www.ptc.panasonic.eu).

## Wall-mounted TZ super-compact · R32

- nanoe™ X technology to improve protection 24/7
- Compact and elegant design with only 779 mm wide
- Built-in Wi-Fi for smart control via Panasonic Comfort Cloud App
- Compatible with Google Assistant and Amazon Alexa
- Easy-to-use remote controller
- Aerowings to control air draft direction

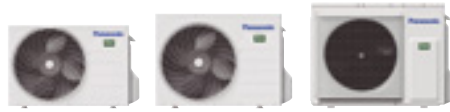

Kit			KIT-TZ20-ZKE	KIT-TZ25-ZKE	KIT-TZ35-ZKE	KIT-TZ42-ZKE	KIT-TZ50-ZKE	KIT-TZ60-ZKE	KIT-TZ71-ZKE
Cooling capacity	Nominal (Min - Max)	kW	2,00(0,75-2,50)	2,50(0,85-3,00)	3,50(0,85-4,00)	4,20(0,85-4,60)	5,00(0,98-5,60)	6,00(0,98-6,60)	7,10(0,98-8,40)
EER <sup>1)</sup>	Nominal (Min - Max)	W/W	4,08(4,17-3,91)	3,85(4,05-3,41)	3,57(3,62-3,33)	3,36(3,62-2,80)	3,13(3,92-2,96)	3,24(3,92-2,87)	3,23(2,33-2,80)
<b>SEER <sup>2)</sup></b>			<b>7,00 A++</b>	<b>7,10 A++</b>	<b>6,80 A++</b>	<b>6,40 A++</b>	<b>6,90 A++</b>	<b>6,80 A++</b>	<b>6,20 A++</b>
Pdesign (cooling)		kW	2,0	2,5	3,5	4,2	5,0	6,0	7,1
Input power	Nominal (Min - Max)	kW	0,49(0,18-0,64)	0,65(0,21-0,88)	0,98(0,24-1,20)	1,25(0,24-1,64)	1,60(0,25-1,89)	1,85(0,25-2,30)	2,20(0,42-3,00)
Annual energy consumption <sup>3)</sup>		kWh/a	100	123	180	230	254	309	401
Heating capacity	Nominal (Min - Max)	kW	2,70(0,70-3,60)	3,30(0,80-4,10)	4,00(0,80-5,10)	5,00(0,80-6,80)	5,80(0,98-7,50)	7,00(0,98-8,20)	8,20(0,98-10,20)
Heating capacity at -7 °C		kW	2,14	2,70	3,30	3,90	4,62	4,90	6,31
COP <sup>1)</sup>	Nominal (Min - Max)	W/W	4,15(4,24-3,53)	4,18(4,21-3,66)	4,04(4,10-3,70)	3,73(4,10-3,33)	3,41(4,67-3,26)	3,72(4,67-3,57)	3,71(2,45-3,29)
<b>SCOP <sup>2)</sup></b>			<b>4,60 A++</b>	<b>4,60 A++</b>	<b>4,60 A++</b>	<b>4,10 A+</b>	<b>4,50 A+</b>	<b>4,30 A+</b>	<b>4,10 A+</b>
Pdesign at -10 °C		kW	2,1	2,4	2,8	3,6	4,0	4,4	5,5
Input power	Nominal (Min - Max)	kW	0,65(0,17-1,02)	0,79(0,19-1,12)	0,99(0,20-1,38)	1,34(0,20-2,04)	1,70(0,21-2,30)	1,88(0,21-2,30)	2,21(0,40-3,10)
Annual energy consumption <sup>3)</sup>		kWh/a	639	730	852	1229	1244	1433	1878
<b>Indoor unit</b>			<b>CS-TZ20ZKEW</b>	<b>CS-TZ25ZKEW</b>	<b>CS-TZ35ZKEW</b>	<b>CS-TZ42ZKEW</b>	<b>CS-TZ50ZKEW</b>	<b>CS-TZ60ZKEW</b>	<b>CS-TZ71ZKEW</b>
Power supply		V	230	230	230	230	230	230	230
Recommended fuse		A	16	16	16	16	16	20	20
Connection indoor / outdoor		mm <sup>2</sup>	4x1,5	4x1,5	4x1,5	4x1,5	4x2,5	4x2,5	4x2,5
Air flow	Cool / Heat	m <sup>3</sup> /min	9,9/10,4	11,0/11,5	11,8/12,3	12,5/13,2	12,5/13,2	18,4/19,4	19,0/19,9
Moisture removal volume		L/h	1,3	1,5	2	2,4	2,8	3,3	4,1
Sound pressure <sup>4)</sup>	Cool (Hi / Lo / Q-Lo)	dB(A)	37/25/20	40/26/20	42/30/20	44/31/25	44/37/33	45/37/34	47/38/35
	Heat (Hi / Lo / Q-Lo)	dB(A)	38/26/22	40/27/22	42/33/22	44/35/28	44/37/33	45/37/34	47/38/35
Dimension	HxWxD	mm	290 x 779 x 209	290 x 779 x 209	290 x 779 x 209	290 x 779 x 209	290 x 779 x 209	295 x 1040 x 244	295 x 1040 x 244
Net weight		kg	8	8	8	8	8	12	13
nanoe X Generator			Mark 1	Mark 1	Mark 1	Mark 1	Mark 1	Mark 1	Mark 1
<b>Outdoor unit</b>			<b>CU-TZ20ZKE</b>	<b>CU-TZ25ZKE</b>	<b>CU-TZ35ZKE</b>	<b>CU-TZ42ZKE</b>	<b>CU-TZ50ZKE</b>	<b>CU-TZ60ZKE</b>	<b>CU-TZ71ZKE</b>
Air flow	Cool / Heat	m <sup>3</sup> /min	29,7/29,7	30,0/28,9	28,7/29,7	31,0/31,3	32,7/32,7	34,4/35,6	44,7/45,8
Sound pressure <sup>4)</sup>	Cool / Heat (Hi)	dB(A)	46/47	47/48	48/50	49/51	48/49	49/51	52/54
Dimension <sup>5)</sup>	HxWxD	mm	542 x 780 x 289	542 x 780 x 289	542 x 780 x 289	542 x 780 x 289	619 x 824 x 299	619 x 824 x 299	695 x 875 x 320
Net weight		kg	24	25	29	31	35	35	45
Piping diameter	Liquid	Inch (mm)	1/4(6,35)	1/4(6,35)	1/4(6,35)	1/4(6,35)	1/4(6,35)	1/4(6,35)	1/4(6,35)
	Gas	Inch (mm)	3/8(9,52)	3/8(9,52)	3/8(9,52)	1/2(12,70)	1/2(12,70)	1/2(12,70)	5/8(15,88)
Pipe length range		m	3-15	3-15	3-15	3-15	3-20	3-30	3-30
Elevation difference (in / out)		m	15	15	15	15	15	15	20
Pre-charged pipe length		m	7,5	7,5	7,5	7,5	10	10	10
Additional gas amount		g/m	10	10	10	10	15	15	25
Refrigerant (R32) / CO <sub>2</sub> Eq.		kg / T	0,52/0,35	0,61/0,41	0,67/0,45	0,79/0,53	1,07/0,72	1,22/0,82	1,35/0,91
Operating range	Cool Min - Max	°C	-10 ~ +43	-10 ~ +43	-10 ~ +43	-10 ~ +43	-10 ~ +43	-10 ~ +43	-10 ~ +43
	Heat Min - Max	°C	-15 ~ +24	-15 ~ +24	-15 ~ +24	-15 ~ +24	-15 ~ +24	-15 ~ +24	-15 ~ +24

1) EER and COP calculation is based in accordance to EN 14511. 2) Energy Label Scale from A+++ to D. 3) The annual energy consumption is calculated in accordance to EU/626/2011. 4) The sound pressure of the indoor unit shows the value measured of a position of 1 m in front of the main body and 0,8 m below the unit. For outdoor unit 1 m in front and 1 m in rear side of main body. The sound pressure is measured in accordance with JIS C 9612. Q-Lo: Quiet mode. Lo: The lowest set fan speed. 5) Add 70 mm for piping port.

## Accessories

**CZ-CAPRA1** RAC interface adapter for integration into S-Link

## Accessories

**CZ-RD517C** Wired remote controller for wall-mounted and floor console



SEER and SCOP: For KIT-TZ25-ZKE. SUPER QUIET: For KIT-TZ20-ZKE, KIT-TZ25-ZKE and KIT-TZ35-ZKE. INTERNET CONTROL: Built-in Wi-Fi.

### Wall-mounted BZ super-compact · R32

- Compact design with only 779 mm wide
- Cleaner air with PM2,5 Filter
- Super Quiet! Only 20 dB(A)
- Aerowings to control air draft direction
- High energy savings
- Cooling even at -10 °C
- Optional internet and voice control



Kit			KIT-BZ25-ZKE	KIT-BZ35-ZKE	KIT-BZ50-ZKE	KIT-BZ60-ZKE
Cooling capacity	Nominal (Min - Max)	kW	2,50 [0,85 - 3,00]	3,30 [0,85 - 3,90]	5,00 [0,98 - 5,40]	6,00 [0,98 - 6,50]
EER <sup>1)</sup>	Nominal (Min - Max)	W/W	3,68 [4,05 - 3,33]	3,24 [3,54 - 3,05]	3,03 [3,92 - 2,90]	3,03 [3,92 - 2,83]
<b>SEER <sup>2)</sup></b>			<b>6,30 A++</b>	<b>6,30 A++</b>	<b>6,50 A++</b>	<b>6,40 A++</b>
Pdesign (cooling)		kW	2,5	3,3	5	6
Input power	Nominal (Min - Max)	kW	0,68 [0,21 - 0,90]	1,02 [0,24 - 1,28]	1,65 [0,25 - 1,86]	1,98 [0,25 - 2,30]
Annual energy consumption <sup>3)</sup>		kWh/a	139	183	269	328
Heating capacity	Nominal (Min - Max)	kW	3,15 [0,80 - 3,60]	3,70 [0,80 - 4,40]	5,40 [0,98 - 7,50]	6,80 [0,98 - 8,00]
Heating capacity at -7 °C		kW	2,14	2,60	4,62	5,1
COP <sup>1)</sup>	Nominal (Min - Max)	W/W	4,09 [4,21 - 3,50]	3,72 [4,10 - 3,49]	3,42 [4,67 - 3,09]	3,16 [4,26 - 3,02]
<b>SCOP <sup>2)</sup></b>			<b>4,30 A+</b>	<b>4,20 A+</b>	<b>4,20 A+</b>	<b>4,10 A+</b>
Pdesign at -10 °C		kW	1,9	2,4	4	4,4
Input power	Nominal (Min - Max)	kW	0,77 [0,19 - 1,03]	1,00 [0,20 - 1,26]	1,58 [0,21 - 2,43]	2,15 [0,23 - 2,65]
Annual energy consumption <sup>3)</sup>		kWh/a	619	800	1333	1502
<b>Indoor unit</b>			<b>CS-BZ25ZKE</b>	<b>CS-BZ35ZKE</b>	<b>CS-BZ50ZKE</b>	<b>CS-BZ60ZKE</b>
Power supply		V	230	230	230	230
Recommended fuse		A	16	16	16	20
Connection indoor / outdoor		mm <sup>2</sup>	4x1,5	4x1,5	4x2,5	4x2,5
Air flow	Cool / Heat	m <sup>3</sup> /min	10,5/9,5	10,8/11,3	12,5/13,2	12,7/13,6
Moisture removal volume		L/h	1,5	1,9	2,8	3,3
Sound pressure <sup>4)</sup>	Cool (Hi / Lo / Q-Lo)	dB(A)	37/26/20	38/30/20	44/37/34	45/37/34
	Heat (Hi / Lo / Q-Lo)	dB(A)	36/27/24	38/33/25	44/37/34	45/37/34
Dimension	H x W x D	mm	290 x 779 x 209	290 x 779 x 209	290 x 779 x 209	290 x 779 x 209
Net weight		kg	8	8	8	9
<b>Outdoor unit</b>			<b>CU-BZ25ZKE</b>	<b>CU-BZ35ZKE</b>	<b>CU-BZ50ZKE</b>	<b>CU-BZ60ZKE</b>
Air flow	Cool / Heat	m <sup>3</sup> /min	30,4/30,4	31,1/30,4	32,7/32,7	42,6/39,2
Sound pressure <sup>4)</sup>	Cool / Heat (Hi)	dB(A)	48/49	48/50	48/49	50/50
Dimension <sup>5)</sup>	H x W x D	mm	542 x 780 x 289	542 x 780 x 289	619 x 824 x 299	695 x 875 x 320
Net weight		kg	24	25	35	40
Piping diameter	Liquid	Inch (mm)	1/4 (6,35)	1/4 (6,35)	1/4 (6,35)	1/4 (6,35)
	Gas	Inch (mm)	3/8 (9,52)	3/8 (9,52)	1/2 (12,70)	1/2 (12,70)
Pipe length range		m	3 ~ 15	3 ~ 15	3 ~ 15	3 ~ 30
Elevation difference (in / out)		m	15	15	15	15
Pre-charged pipe length		m	7,5	7,5	10	7,5
Additional gas amount		g/m	10	10	15	15
Refrigerant (R32) / CO <sub>2</sub> Eq.		kg / T	0,52/0,35	0,61/0,41	1,07/0,72	1,11/0,75
Operating range	Cool Min ~ Max	°C	-10 ~ +43	-10 ~ +43	-10 ~ +43	-10 ~ +43
	Heat Min ~ Max	°C	-15 ~ +24	-15 ~ +24	-15 ~ +24	-15 ~ +24

1) EER and COP calculation is based in accordance to EN 14511. 2) Energy Label Scale from A+++ to D. 3) The annual energy consumption is calculated in accordance to EU/626/2011. 4) The sound pressure of the indoor unit shows the value measured of a position of 1 m in front of the main body and 0,8 m below the unit. For outdoor unit 1 m in front and 1 m in rear side of main body. The sound pressure is measured in accordance with JIS C 9612. Q-Lo: Quiet mode. Lo: The lowest set fan speed. 5) Add 70 mm for piping port.

#### Accessories

<b>CZ-TACG1</b>	Wi-Fi adapter for smart control via Panasonic Comfort Cloud App
<b>CZ-CAPRA1</b>	RAC interface adapter for integration into S-Link

#### Accessories

<b>CZ-RD517C</b>	Wired remote controller for wall-mounted and floor console
------------------	--



SEER: For KIT-BZ50-ZKE. SCOP: For KIT-BZ25-ZKE. SUPER QUIET: For KIT-BZ25-ZKE and KIT-BZ35-ZKE. INTERNET CONTROL: Optional.

Rating conditions: Cooling indoor 27 °C DB / 19 °C WB. Cooling outdoor 35 °C DB / 24 °C WB. Heating indoor 20 °C DB. Heating outdoor 7 °C DB / 6 °C WB. (DB: Dry Bulb; WB: Wet Bulb). Specifications subject to change without notice. For detailed information about ErP / Energy Labelling, please visit our websites [www.aircon.panasonic.eu](http://www.aircon.panasonic.eu) or [www.ptc.panasonic.eu](http://www.ptc.panasonic.eu).

## Wall-mounted UZ super-compact · R32

- Compact design with only 779 mm wide
- Dust Collection Filter
- Super Quiet! Only 20 dB(A)
- Aerowings to control air draft direction
- High energy savings
- Cooling even at -10 °C
- Optional internet and voice control



Kit			KIT-UZ25-ZKE	KIT-UZ35-ZKE	KIT-UZ50-ZKE
Cooling capacity	Nominal (Min - Max)	kW	2,50 (0,85 - 3,00)	3,30 (0,85 - 3,90)	5,00 (0,98 - 5,40)
EER <sup>1)</sup>	Nominal (Min - Max)	W/W	3,68 (4,05 - 3,33)	3,24 (3,54 - 3,00)	3,03 (3,92 - 2,89)
<b>SEER <sup>2)</sup></b>			<b>6,20 A++</b>	<b>6,20 A++</b>	<b>6,50 A++</b>
Pdesign (cooling)		kW	2,5	3,3	5
Input power	Nominal (Min - Max)	kW	0,68 (0,21 - 0,90)	1,02 (0,24 - 1,30)	1,65 (0,25 - 1,87)
Annual energy consumption <sup>3)</sup>		kWh/a	141	186	269
Heating capacity	Nominal (Min - Max)	kW	3,15 (0,80 - 3,60)	3,70 (0,80 - 4,40)	5,40 (0,98 - 7,40)
Heating capacity at -7 °C		kW	2,14	2,60	4,52
COP <sup>1)</sup>	Nominal (Min - Max)	W/W	4,06 (4,21 - 3,50)	3,72 (4,10 - 3,46)	3,42 (4,67 - 3,08)
<b>SCOP <sup>2)</sup></b>			<b>4,20 A+</b>	<b>4,10 A+</b>	<b>4,10 A+</b>
Pdesign at -10 °C		kW	1,9	2,4	4
Input power	Nominal (Min - Max)	kW	0,78 (0,19 - 1,03)	1,00 (0,20 - 1,27)	1,58 (0,21 - 2,40)
Annual energy consumption <sup>3)</sup>		kWh/a	633	820	1366
<b>Indoor unit</b>			<b>CS-UZ25ZKE</b>	<b>CS-UZ35ZKE</b>	<b>CS-UZ50ZKE</b>
Power supply		V	230	230	230
Recommended fuse		A	16	16	16
Connection indoor / outdoor		mm <sup>2</sup>	4x1,5	4x1,5	4x2,5
Air flow	Cool / Heat	m <sup>3</sup> /min	10,5/9,5	10,8/11,3	12,5/13,2
Moisture removal volume		L/h	1,5	1,9	2,8
Sound pressure <sup>4)</sup>	Cool (Hi / Lo / Q-Lo)	dB(A)	37/26/20	38/30/20	44/37/34
	Heat (Hi / Lo / Q-Lo)	dB(A)	36/27/24	38/33/25	44/37/34
Dimension	H x W x D	mm	290 x 779 x 209	290 x 779 x 209	290 x 779 x 209
Net weight		kg	8	8	8
<b>Outdoor unit</b>			<b>CU-UZ25ZKE</b>	<b>CU-UZ35ZKE</b>	<b>CU-UZ50ZKE</b>
Air flow	Cool / Heat	m <sup>3</sup> /min	30,4/30,4	31,1/30,4	32,7/32,7
Sound pressure <sup>4)</sup>	Cool / Heat (Hi)	dB(A)	48/49	48/50	48/49
Dimension <sup>5)</sup>	H x W x D	mm	542 x 780 x 289	542 x 780 x 289	619 x 824 x 299
Net weight		kg	24	25	35
Piping diameter	Liquid	Inch (mm)	1/4 (6,35)	1/4 (6,35)	1/4 (6,35)
	Gas	Inch (mm)	3/8 (9,52)	3/8 (9,52)	1/2 (12,70)
Pipe length range		m	3 - 15	3 - 15	3 - 15
Elevation difference (in / out)		m	15	15	15
Pre-charged pipe length		m	7,5	7,5	10
Additional gas amount		g/m	10	10	15
Refrigerant (R32) / CO <sub>2</sub> Eq.		kg / T	0,52/0,35	0,61/0,41	1,07/0,72
Operating range	Cool Min ~ Max	°C	-10 ~ +43	-10 ~ +43	-10 ~ +43
	Heat Min ~ Max	°C	-15 ~ +24	-15 ~ +24	-15 ~ +24

1) EER and COP calculation is based in accordance to EN 14511. 2) Energy Label Scale from A+++ to D. 3) The annual energy consumption is calculated in accordance to EU/626/2011. 4) The sound pressure of the indoor unit shows the value measured at a position of 1 m in front of the main body and 0,8 m below the unit. For outdoor unit 1 m in front and 1 m in rear side of main body. The sound pressure is measured in accordance with JIS C 9612. Q-Lo: Quiet mode. Lo: The lowest set fan speed. 5) Add 70 mm for piping port.

Accessories	
<b>CZ-TACG1</b>	Wi-Fi adapter for smart control via Panasonic Comfort Cloud App
<b>CZ-CAPRA1</b>	RAC interface adapter for integration into S-Link

Accessories	
<b>CZ-RD517C</b>	Wired remote controller for wall-mounted and floor console



SEER: For KIT-UZ50-ZKE. SCOP: For KIT-UZ25-ZKE. SUPER QUIET: For KIT-UZ25-ZKE and KIT-UZ35-ZKE. INTERNET CONTROL: Optional.

## Floor console · R32

- nanoe™ X technology to improve protection 24/7 (nanoe X Generator Mark 1)
- Stylish Sky remote controller
- A breakthrough design that integrates perfectly with the most modern environments
- High energy efficiency class A++ SEER and A++ SCOP
- Optional internet and voice control



Kit			KIT-Z25-UFE	KIT-Z35-UFE	KIT-Z50-UFE
Cooling capacity	Nominal (Min - Max)	kW	2,50 (0,85 - 3,40)	3,50 (0,85 - 3,80)	5,00 (0,90 - 5,70)
EER <sup>1)</sup>	Nominal (Min - Max)	W/W	4,81 (3,54 - 3,78)	4,07 (3,54 - 3,73)	3,60 (3,53 - 3,15)
<b>SEER <sup>2)</sup></b>			<b>7,90 A++</b>	<b>8,10 A++</b>	<b>6,70 A++</b>
P <sub>design</sub> (cooling)		kW	2,50	3,50	5,00
Input power	Nominal (Min - Max)	kW	0,52 (0,24 - 0,90)	0,86 (0,24 - 1,02)	1,39 (0,26 - 1,81)
Annual energy consumption <sup>3)</sup>		kWh/a	111	151	261
Heating capacity	Nominal (Min - Max)	kW	3,40 (0,85 - 5,00)	4,30 (0,85 - 6,00)	5,80 (0,90 - 8,10)
Heating capacity at -7 °C		kW	2,88	3,37	5,03
COP <sup>1)</sup>	Nominal (Min - Max)	W/W	4,47 (3,54 - 3,70)	3,98 (3,54 - 3,43)	3,74 (3,46 - 3,12)
<b>SCOP <sup>2)</sup></b>			<b>4,60 A++</b>	<b>4,60 A++</b>	<b>4,30 A+</b>
P <sub>design</sub> at -10 °C		kW	2,70	3,20	4,40
Input power	Nominal (Min - Max)	kW	0,76 (0,24 - 1,35)	1,08 (0,24 - 1,75)	1,55 (0,26 - 2,60)
Annual energy consumption <sup>3)</sup>		kWh/a	822	974	1433
<b>Indoor unit</b>			<b>CS-Z25UFEAW</b>	<b>CS-Z35UFEAW</b>	<b>CS-Z50UFEAW</b>
Air flow	Cool / Heat	m <sup>3</sup> /min	9,6/9,9	9,9/10,1	11,6/13,2
Moisture removal volume		L/h	1,5	2,0	2,8
Sound pressure <sup>4)</sup>	Cool (Hi / Lo / Q-Lo)	dB(A)	38/25/20	39/26/20	44/31/27
	Heat (Hi / Lo / Q-Lo)	dB(A)	38/25/19	39/26/19	46/33/29
Dimension	H x W x D	mm	600 x 750 x 207	600 x 750 x 207	600 x 750 x 207
Net weight		kg	13	13	13
nanoe X Generator			Mark 1	Mark 1	Mark 1
<b>Outdoor unit</b>			<b>CU-Z25UBEA</b>	<b>CU-Z35UBEA</b>	<b>CU-Z50UBEA</b>
Power supply		V	230	230	230
Recommended fuse		A	16	16	16
Connection indoor / outdoor		mm <sup>2</sup>	4x1,5	4x1,5	4x1,5
Air flow	Cool / Heat	m <sup>3</sup> /min	28,7/27,2	34,3/33,5	39,7/38,6
Sound pressure <sup>4)</sup>	Cool / Heat (Hi)	dB(A)	46/47	48/48	48/48
Dimension <sup>5)</sup>	H x W x D	mm	542 x 780 x 289	619 x 824 x 299	695 x 875 x 320
Net weight		kg	33	35	43
Piping diameter	Liquid	Inch (mm)	1/4 (6,35)	1/4 (6,35)	1/4 (6,35)
	Gas	Inch (mm)	3/8 (9,52)	3/8 (9,52)	1/2 (12,70)
Pipe length range		m	3 - 20	3 - 20	3 - 30
Elevation difference (in / out)		m	15	15	20
Pre-charged pipe length		m	7,5	7,5	7,5
Additional gas amount		g/m	10	10	15
Refrigerant (R32) / CO <sub>2</sub> Eq.		kg / T	0,88/0,594	0,93/0,628	1,13/0,763
Operating range	Cool Min ~ Max	°C	-10 ~ +43	-10 ~ +43	-10 ~ +43
	Heat Min ~ Max	°C	-15 ~ +24	-15 ~ +24	-15 ~ +24

1) EER and COP calculation is based in accordance to EN 14511. 2) Energy Label Scale from A+++ to D. 3) The annual energy consumption is calculated in accordance to EU/626/2011. 4) The sound pressure of the units shows the value measured of a position 1 m in front of the main body and 1 m above floor. The sound pressure is measured in accordance with JIS C 9612. Q-Lo: Quiet mode. Lo: The lowest set fan speed. 5) Add 70 mm for piping port.

## Accessories

**CZ-TACG1** Wi-Fi adapter for smart control via Panasonic Comfort Cloud App

**CZ-CAPRA1** RAC interface adapter for integration into S-Link

## Accessories

**CZ-RD517C** Wired remote controller for wall-mounted and floor console



SEER and SCOP: For KIT-Z35-UFE. SUPER QUIET: For KIT-Z25-UFE and KIT-Z35-UFE. INTERNET CONTROL: Optional. IF DESIGN AWARD 2019: Floor console awarded with the prestigious IF Design Award 2019.

Rating conditions: Cooling indoor 27 °C DB / 19 °C WB. Cooling outdoor 35 °C DB / 24 °C WB. Heating indoor 20 °C DB. Heating outdoor 7 °C DB / 6 °C WB. (DB: Dry Bulb; WB: Wet Bulb). Specifications subject to change without notice. For detailed information about ErP / Energy Labelling, please visit our websites [www.aircon.panasonic.eu](http://www.aircon.panasonic.eu) or [www.ptc.panasonic.eu](http://www.ptc.panasonic.eu).

## Low static pressure hide-away · R32

- Duct type can be controlled by KNX and Modbus
- Eco mode for 20% energy saving
- Extremely compact indoor units without losing static pressure (only 200 mm high)
- Weekly timer, 42 settings per week
- Easy check mode for failure detection
- Drain pump included



Optional wireless control kit. CZ-RL511D

## MORE DUCT TYPE SOLUTIONS IN PACI SECTION

Kit			KIT-Z25-UD3	KIT-Z35-UD3	KIT-Z50-UD3	KIT-Z60-UD3
Cooling capacity	Nominal (Min - Max)	kW	2,50 (0,85 - 3,20)	3,50 (0,85 - 4,00)	5,10 (0,90 - 5,70)	6,00 (0,90 - 6,50)
EER <sup>1)</sup>	Nominal (Min - Max)	W/W	4,31 (3,54 - 3,76)	3,85 (3,54 - 3,36)	3,27 (3,53 - 3,20)	2,94 (3,53 - 2,83)
<b>SEER <sup>2)</sup></b>			<b>5,90 A+</b>	<b>5,80 A+</b>	<b>5,90 A+</b>	<b>5,60 A+</b>
Pdesign (cooling)		kW	2,50	3,50	5,10	6,00
Input power	Nominal (Min - Max)	kW	0,58 (0,24 - 0,85)	0,91 (0,24 - 1,19)	1,56 (0,26 - 1,78)	2,04 (0,26 - 2,30)
Annual energy consumption <sup>3)</sup>		kWh/a	148	211	303	375
Heating capacity	Nominal (Min - Max)	kW	3,20 (0,85 - 4,60)	4,20 (0,85 - 5,10)	6,10 (0,90 - 7,20)	7,00 (0,90 - 8,00)
Heating capacity at -7 °C		kW	2,60	3,00	4,50	5,10
COP <sup>1)</sup>	Nominal (Min - Max)	W/W	4,00 (3,70 - 3,68)	3,82 (3,70 - 3,59)	3,35 (3,46 - 3,27)	3,24 (3,46 - 3,08)
<b>SCOP <sup>2)</sup></b>			<b>4,20 A+</b>	<b>4,10 A+</b>	<b>4,10 A+</b>	<b>4,10 A+</b>
Pdesign at -10 °C		kW	2,60	2,80	4,00	4,60
Input power	Nominal (Min - Max)	kW	0,80 (0,23 - 1,25)	1,10 (0,23 - 1,42)	1,82 (0,26 - 2,20)	2,16 (0,26 - 2,60)
Annual energy consumption <sup>3)</sup>		kWh/a	867	956	1366	1571
<b>Indoor unit</b>			<b>CS-Z25UD3EAW</b>	<b>CS-Z35UD3EAW</b>	<b>CS-Z50UD3EAW</b>	<b>CS-Z60UD3EAW</b>
External static pressure <sup>4)</sup>	Min - Max	Pa	15 - 45	15 - 45	15 - 50	15 - 50
Air flow	Cool / Heat	m <sup>3</sup> /min	10,5 / 10,5	11,2 / 11,2	15,3 / 15,3	15,7 / 15,7
Moisture removal volume		L/h	1,5	2,0	2,8	3,3
Sound pressure <sup>5)</sup>	Cool (Hi / Lo / Q-Lo)	dB(A)	33 / 27 / 24	33 / 27 / 24	39 / 29 / 26	41 / 30 / 27
	Heat (Hi / Lo / Q-Lo)	dB(A)	35 / 27 / 24	35 / 27 / 24	39 / 30 / 27	41 / 32 / 29
Dimension	H x W x D	mm	200 x 750 x 640	200 x 750 x 640	200 x 750 x 640	200 x 750 x 640
Net weight		kg	19	19	19	19
<b>Outdoor unit</b>			<b>CU-Z25UBEA</b>	<b>CU-Z35UBEA</b>	<b>CU-Z50UBEA</b>	<b>CU-Z60UBEA</b>
Power supply		V	230	230	230	230
Recommended fuse		A	16	16	16	—
Connection indoor / outdoor		mm <sup>2</sup>	4x1,5 - 2,5	4x1,5 - 2,5	4x1,5 - 2,5	—
Air flow	Cool / Heat	m <sup>3</sup> /min	28,7 / 27,2	34,3 / 33,5	39,7 / 38,6	42,6 / 41,5
Sound pressure <sup>5)</sup>	Cool / Heat (Hi)	dB(A)	46 / 47	48 / 48	48 / 48	49 / 50
Dimension <sup>6)</sup>	H x W x D	mm	542 x 780 x 289	619 x 824 x 299	695 x 875 x 320	695 x 875 x 320
Net weight		kg	33	35	43	43
Piping diameter	Liquid	Inch (mm)	1/4 (6,35)	1/4 (6,35)	1/4 (6,35)	1/4 (6,35)
	Gas	Inch (mm)	3/8 (9,52)	3/8 (9,52)	1/2 (12,70)	1/2 (12,70)
Pipe length range		m	3 - 20	3 - 20	3 - 30	3 - 30
Elevation difference (in / out)		m	15	15	20	20
Pre-charged pipe length		m	7,5	7,5	7,5	7,5
Additional gas amount		g/m	10	10	15	15
Refrigerant (R32) / CO <sub>2</sub> Eq.		kg / T	0,88 / 0,594	0,93 / 0,628	1,13 / 0,763	1,13 / 0,763
Operating range	Cool Min ~ Max	°C	-10 ~ +43	-10 ~ +43	-10 ~ +43	-10 ~ +43
	Heat Min ~ Max	°C	-15 ~ +24	-15 ~ +24	-15 ~ +24	-15 ~ +24

1) EER and COP calculation is based in accordance to EN 14511. 2) Energy Label Scale from A+++ to D. 3) The annual energy consumption is calculated in accordance to EU/626/2011. 4) The specification listed on the table indicates values under the condition of 25 Pa (2,5 mmAq) which are applied for factory default setting. Change switch on PCB from Hi to S-Hi to have more than 6,0 mmAq. 5) The sound pressure of the indoor unit shows the value measured of a position of 1,5 m below the unit with 1 m duct on the suction side and 2 m duct on the discharge side. For outdoor unit 1 m in front and 1 m in rear side of main body. The sound pressure is measured in accordance with JIS C 9612. 6) Add 100 mm for indoor unit or 70 mm for outdoor unit for piping port.

## Accessories

<b>CZ-TACG1</b>	Wi-Fi adapter for smart control via Panasonic Comfort Cloud App
-----------------	---



















## Accessories

<b>CZ-CAPRA1</b>	RAC interface adapter for integration into S-Link
<b>CZ-RL511D</b>	Optional wireless control kit

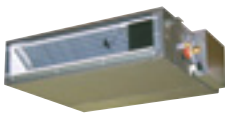

SEER and SCOP: For KIT-Z25-UD3. INTERNET CONTROL: Optional.

# Compare split solutions

	Indoor unit dimension	Efficiency <sup>1)</sup>	Indoor air quality	Outdoor temperature	Comfort	Super Quiet	Connectivity
<b>Wall-mounted Heatcharge VZ - 2,5 to 3,5 kW</b> 	295 x <b>798</b> x 375	<b>A+++</b> <b>A+++</b>	 nanoe	<b>-10 °C</b> in cooling mode <b>-30 °C</b> in heating mode	Econavi sunlight detection sensor	 <b>18 dB(A)</b>	Optional Wi-Fi CZ-TACG1
<b>Wall-mounted Etherea - 2,0 to 7,1 kW</b> 	295 x <b>870</b> x 229 (295x1040x244 wide model)	<b>A+++</b> <b>A+++</b>	 nanoe X Generator Mark 3	<b>-10 °C</b> in cooling mode <b>-20 °C</b> in heating mode	Aerowings 2.0	 <b>19 dB(A)</b>	<b>Built-in Wi-Fi</b>
<b>Wall-mounted TZ super-compact - 2,0 to 7,1 kW</b> 	290 x <b>779</b> x 209 (295x1040x244 wide model)	<b>A++</b> <b>A++</b>	 nanoe X Generator Mark 1	<b>-10 °C</b> in cooling mode <b>-15 °C</b> in heating mode	Aerowings	 <b>20 dB(A)</b>	<b>Built-in Wi-Fi</b>
<b>Wall-mounted BZ super-compact - 2,5 to 6,0 kW</b> 	290 x <b>779</b> x 209	<b>A++</b> <b>A+</b>	PM2,5 Filter	<b>-10 °C</b> in cooling mode <b>-15 °C</b> in heating mode	Aerowings	 <b>20 dB(A)</b>	Optional Wi-Fi CZ-TACG1
<b>Wall-mounted UZ super-compact - 2,5 to 5,0 kW</b> 	290 x <b>779</b> x 209	<b>A++</b> <b>A+</b>	Dust collection filter	<b>-10 °C</b> in cooling mode <b>-15 °C</b> in heating mode	Aerowings	 <b>20 dB(A)</b>	Optional Wi-Fi CZ-TACG1
<b>Floor console - 2,5 to 5,0 kW</b> 	600 x 750 x 207	<b>A++</b> <b>A++</b>	 nanoe X Generator Mark 1	<b>-10 °C</b> in cooling mode <b>-15 °C</b> in heating mode	Double air flow	 <b>20 dB(A)</b>	Optional Wi-Fi CZ-TACG1
<b>Low static pressure hide-away - 2,5 to 6,0 kW</b> 	200 x 750 x 640	<b>A+</b> <b>A+</b>	Air filter	<b>-10 °C</b> in cooling mode <b>-15 °C</b> in heating mode	Weekly timer	 <b>24 dB(A)</b>	Optional Wi-Fi CZ-TACG1

<sup>1)</sup> Energy efficiency class in 2,5 kW references. \* All data in this chart is applicable in most of the models in each line up, check product specifications to confirm.

# Multi split systems

When the heating and cooling requirements exceed the scope of a single room, Panasonic offers a wide range of options with a multi split solution.

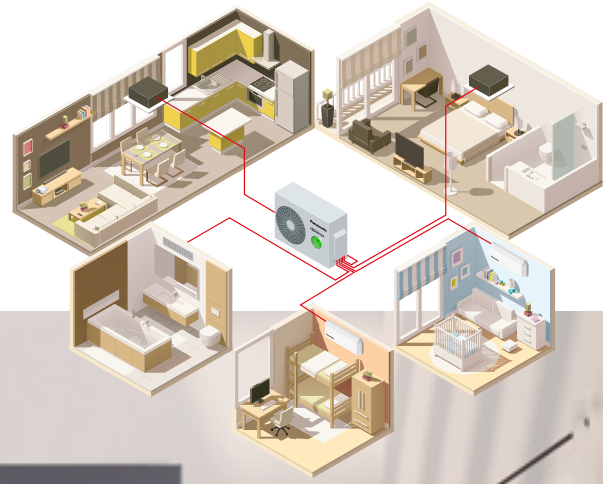

Panasonic multi split systems - a range to suit every need. High flexibility in installation, while reducing aesthetic impact and maximising comfort.

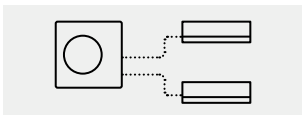

**Multiple indoor units with only one outdoor.**  
Individual control of each indoor.



**Wide range of connectable units.**  
Wall-mounted, floor console and cassette with nanoe™ X.

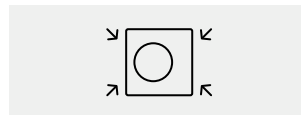

**Seamless integration of outdoor unit.**  
Reduced outdoor unit space, harmonizing with building architecture.



**Reduced installation time.**  
Faster piping connection and pump-down time.

## Why choose a multi split system?

With one indoor unit per room or area with individual control, it is easy to achieve the desired level of comfort throughout the home. Outside, there is only one unit, which reduces the space required for the outdoor unit, improves the aesthetics of the building and makes installation easier.

Solution with multi split.

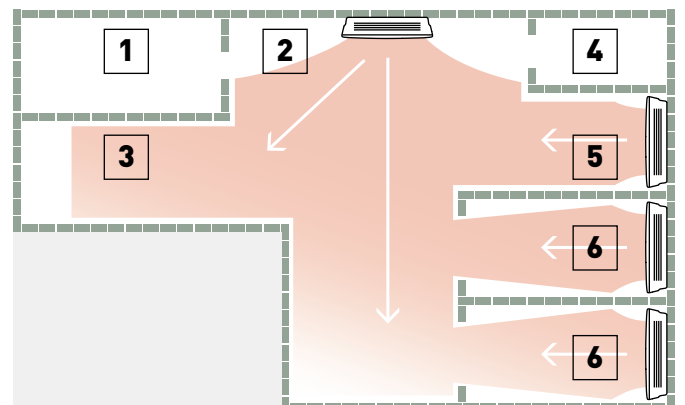

1. Laundry room. 2. Entrance. 3. Kitchen / dining area. 4. Bathroom. 5. Living room. 6. Bedroom.



### Free Multi system. High flexibility for maximising comfort.

Full flexibility up to 9,0 kW and up to 5 ports with wide range of indoor units including high performance Etherea indoor units, reaching up to A+++ / A++.

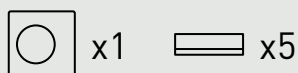

Up to 5 indoor units  
with only one outdoor.



Wide range of compatible  
indoors with nanoe™ X.

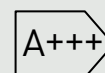

SEER.  
High energy efficiency class.

### Power Heat Multi system. Reliable heating for cold winters.

Powerful heating of two or three rooms with one outdoor unit, even at -25 °C low outdoor temperatures.

## POWER HEAT

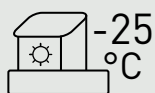

Reliable heating  
even at -25 °C.



Equipped with  
base pan heater.



Excellent  
maintainability.  
Advantageous under harsh  
conditions.

#### -25 °C outdoor temperature operation and base pan heater.

The heater prevents the outdoor unit base pan from freezing and ensures stable operation even in extremely cold regions.

#### Heating capacity at -25 °C outdoor temperature: 3,90 kW for the 2-room model and 4,30 kW for the 3-room model.

Efficiently heats 2 or 3 rooms using a single outdoor unit, even in low outdoor temperatures.

#### High efficiency SCOP 4,60 A++.

High heating efficiency contributes to environmental protection while reducing electricity bills.



#### Dark color outdoor unit.

First outdoor unit in dark color, blending seamlessly with home exteriors without compromising aesthetics.

#### Connectable to Etherea indoor units.

Comfort and convenience with nanoe™ X and built-in Wi-Fi, combined with excellent heating and cooling performance.

### Multi TZ. The super compact multi split solution.

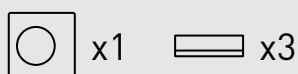

Up to 3 indoor units with  
only one outdoor.



Compact outdoor unit, to minimise  
outdoor unit space.



Compatible with TZ super-  
compact indoor units, with  
nanoe™ X.

# Free Multi system

## Outdoor units Free Multi system Z · R32

- Up to 5 indoor units with a single outdoor unit
- Up to 5 rooms with individual control
- Etherea, TZ super-compact, floor console and 4 way 60x60 cassette with nanoe™ X technology to improve protection 24/7
- High energy efficiency class A+++ SEER
- Indoor units compatible with internet and voice control

Configure your multi split system in a few steps using our online tool and see all possible combinations.



Outdoor unit			CU-2Z35TBE	CU-2Z41TBE	CU-2Z50TBE	CU-3Z52TBE	CU-3Z68TBE	CU-4Z68TBE	CU-4Z80TBE	CU-5Z90TBE
Indoor nominal capacity (Min - Max)			3,2~6,0 kW	3,2~6,0 kW	3,2~7,7 kW	4,5~9,5 kW	4,5~11,2 kW	4,5~11,5 kW	4,5~14,7 kW	4,5~18,3 kW
Cooling capacity	Nominal	kW	3,50	4,10	5,00	5,20	6,80	6,80	8,00	9,00
	Min		1,50	1,50	1,50	1,80	1,90	1,90	3,00	2,90
	Max		4,50	5,20	5,40	7,30	8,00	8,80	9,20	11,50
EER <sup>1)</sup>	Nominal	W/W	4,86	4,56	4,24	4,77	3,66	4,39	4,04	4,09
	Min		6,00	6,00	6,00	—	7,04	5,59	5,66	5,27
	Max		4,09	3,80	3,62	—	3,38	3,56	3,21	2,98
<b>SEER <sup>2)</sup></b>			<b>8,50 A+++</b>	<b>8,50 A+++</b>	<b>8,50 A+++</b>	<b>8,50 A+++</b>	<b>8,00 A++</b>	<b>8,00 A++</b>	<b>7,90 A++</b>	<b>8,50 A+++</b>
Pdesign (cooling)	kW		3,50	4,10	5,00	5,20	6,80	6,80	8,00	9,00
Input power	Nominal	kW	0,72	0,90	1,18	1,09	1,86	1,55	1,98	2,20
	Min		0,25	0,25	0,25	0,36	0,27	0,34	0,53	0,55
	Max		1,10	1,37	1,49	2,18	2,37	2,47	2,87	3,86
Annual energy consumption <sup>3)</sup>	kWh/a		144	169	206	214	298	298	990	1100
Heating capacity	Nominal	kW	4,20	4,60	5,60	6,80	8,50	8,50	9,40	10,40
	Min		1,10	1,10	1,10	1,60	3,30	3,00	4,20	3,40
	Max		5,60	7,00	7,20	8,30	10,40	10,60	10,60	14,50
Heating capacity at -7 °C	kW		3,39	4,18	4,28	3,95	4,45	4,45	6,42	8,62
COP <sup>1)</sup>	Nominal	W/W	4,88	4,79	4,63	4,63	3,95	4,47	4,63	4,84
	Min		5,24	5,24	5,24	5,00	5,32	5,17	6,00	6,42
	Max		4,18	3,91	4,00	3,82	3,64	3,96	3,46	3,42
<b>SCOP <sup>2)</sup></b>			<b>4,60 A++</b>	<b>4,60 A++</b>	<b>4,60 A++</b>	<b>4,20 A+</b>	<b>4,20 A+</b>	<b>4,20 A+</b>	<b>4,70 A++</b>	<b>4,68 A++</b>
Pdesign at -10 °C	kW		3,20	3,50	4,20	5,00	5,20	5,80	6,80	8,50
Input power	Nominal	kW	0,86	0,96	1,21	1,47	2,15	1,90	2,03	2,15
	Min		0,21	0,21	0,21	0,32	0,62	0,58	0,70	0,53
	Max		1,34	1,79	1,80	2,17	2,86	2,68	3,06	4,24
Annual energy consumption <sup>3)</sup>	kWh/a		974	1065	1278	1667	1733	1933	2026	2543
Current	Cool / Heat	A	3,35/4,00	4,15/4,45	5,35/5,50	5,00/6,70	8,40/9,70	7,00/8,60	9,50/9,50	10,50/10,10
Power supply	V		230	230	230	230	230	230	230	230
Recommended fuse	A		16	16	16	16	16	20	20	25
Recommended power cable section	mm <sup>2</sup>		2,5	2,5	2,5	2,5	2,5	2,5	2,5	4,0
Sound pressure <sup>4)</sup>	Cool / Heat (Hi)	dB(A)	48/50	48/50	50/52	47/48	51/52	49/50	51/52	53/54
Dimension <sup>5)</sup>	H x W x D	mm	619x824x299	619x824x299	619x824x299	795x875x320	795x875x320	795x875x320	999x940x340	999x940x340
Net weight	kg		39	39	39	71	71	72	80	81
Piping diameter	Liquid	Inch (mm)	1/4 (6,35)	1/4 (6,35)	1/4 (6,35)	1/4 (6,35)	1/4 (6,35)	1/4 (6,35)	1/4 (6,35)	1/4 (6,35)
	Gas	Inch (mm)	3/8 (9,52)	3/8 (9,52)	3/8 (9,52)	3/8 (9,52)	3/8 (9,52)	3/8 (9,52)	3/8 (9,52)	3/8 (9,52)
Pipe length range total <sup>6)</sup>	m		6~30	6~30	6~30	6~50	6~60	6~60	6~70	6~80
Pipe length range to one unit	m		3~20	3~20	3~20	3~25	3~25	3~25	3~25	3~25
Elevation difference (in / out)	m		10	10	10	15	15	15	15	15
Pre-charged pipe length	m		20	20	20	30	30	30	45	45
Additional gas amount	g/m		15	15	15	20	20	20	20	20
Refrigerant (R32) / CO <sub>2</sub> Eq.	kg / T		1,12/0,756	1,12/0,756	1,12/0,756	2,10/1,418	2,10/1,418	2,10/1,418	2,72/1,836	2,72/1,836
Operating range	Cool Min ~ Max	°C	-10~+46	-10~+46	-10~+46	-10~+46	-10~+46	-10~+46	-10~+46	-10~+46
	Heat Min ~ Max	°C	-15~+24	-15~+24	-15~+24	-15~+24	-15~+24	-15~+24	-15~+24	-15~+24

1) EER and COP calculation is based in accordance to EN 14511. 2) Energy Label Scale from A+++ to D. 3) The annual energy consumption is calculated in accordance to EU/626/2011. 4) The sound pressure of the units shows the value measured of a position 1 m in front and 1 m in rear side of the main body. The sound pressure is measured in accordance with JIS C 9612. 5) Add 70 or 95 mm for piping port. 6) Minimum piping length is 3 meters per indoor unit.

### Possible outdoor / indoor units combinations

Rooms	Outdoor unit	Indoor capacity connected (Min - Max)	Wall-mounted Etherea							Wall-mounted TZ super-compact							Floor console				4 Way 60x60 cassette					Low static pressure hide-away								
			16	20	25	35	42	50	71	16	20	25	35	42	50	60	71	20	25	35	50	20	25	35	50	60	20	25	35	50	60			
2	CU-2Z35TBE	3,2~6,0 kW	•	•	•	•	•																											
	CU-2Z41TBE	3,2~6,0 kW	•	•	•	•	•																											
	CU-2Z50TBE	3,2~7,7 kW	•	•	•	•	• <sup>1)</sup>	• <sup>1)</sup>																										
3	CU-3Z52TBE	4,5~9,5 kW	•	•	•	•	• <sup>1)</sup>	• <sup>1)</sup>																										
	CU-3Z68TBE	4,5~11,2 kW	•	•	•	•	• <sup>1)</sup>	• <sup>1)</sup>																										
4	CU-4Z68TBE	4,5~11,5 kW	•	•	•	•	• <sup>1)</sup>	• <sup>1)</sup>																										
	CU-4Z80TBE	4,5~14,7 kW	•	•	•	•	• <sup>1)</sup>	• <sup>1)</sup>	• <sup>3)</sup>																									
5	CU-5Z90TBE	4,5~18,3 kW	•	•	•	•	• <sup>1)</sup>	• <sup>1)</sup>	• <sup>3)</sup>																									

1) Pipe reducer CZ-MA1PA required. 2) Pipe reducer CZ-MA2PA required. 3) Pipe reducers CZ-MA2PA and CZ-MA3PA required.





Optional wired remote controller. CZ-RD517C

INTERNET CONTROL: Built-in Wi-Fi.



Wall-mounted Etherea	Indoor unit graphite grey	Indoor unit silver	Indoor unit matt white	Cooling capacity	Heating capacity	Connection in. / out.	Sound pressure <sup>1)</sup>		Dimension / Net weight	Piping diameter
							Cool — Heat (Hi/Lo/Q-Lo)	dB(A)		
1,6 kW	—	—	CS-MZ16ZKE	1,60	2,60	4x1,5	38/26/21	— 39/27/21	295x870x229/10	1/4(6,35)/3/8(9,52)
2,0 kW	CS-XZ20ZKEW-H	CS-XZ20ZKEW	CS-Z20ZKEW	2,00	3,20	4x1,5	39/26/21	— 40/27/21	295x870x229/10	1/4(6,35)/3/8(9,52)
2,5 kW	CS-XZ25ZKEW-H	CS-XZ25ZKEW	CS-Z25ZKEW	2,50	3,60	4x1,5	41/27/21	— 43/29/21	295x870x229/10	1/4(6,35)/3/8(9,52)
3,5 kW <sup>2)</sup>	CS-XZ35ZKEW-H	CS-XZ35ZKEW	CS-Z35ZKEW	3,50	4,50	4x1,5	44/30/21	— 45/35/21	295x870x229/11	1/4(6,35)/3/8(9,52)
4,2 kW <sup>3)</sup>	CS-XZ42ZKEW-H	—	CS-Z42ZKEW	4,20	5,60	4x1,5	44/33/27	— 45/37/31	295x870x229/10	1/4(6,35)/1/2(12,70)
5,0 kW <sup>4)</sup>	—	CS-XZ50ZKEW	CS-Z50ZKEW	5,00	6,80	4x2,5	44/39/32	— 46/39/32	295x1040x244/12	1/4(6,35)/1/2(12,70)
7,1 kW	—	—	CS-Z71ZKEW	7,10	8,70	4x2,5	49/40/32	— 49/40/32	295x1040x244/13	1/4(6,35)/5/8(15,88)

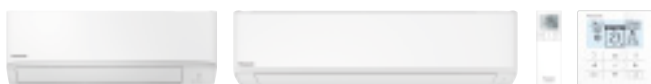

Optional wired remote controller. CZ-RD517C

INTERNET CONTROL: Built-in Wi-Fi.



Wall-mounted TZ super-compact	Indoor unit	Cooling capacity	Heating capacity	Connection in. / out.	Sound pressure <sup>1)</sup>		Dimension / Net weight	Piping diameter
					Cool — Heat (Hi/Lo/Q-Lo)	dB(A)		
1,6 kW	CS-MTZ16ZKE	1,60	2,60	4x1,5	38/27/22	— 39/28/24	290x779x209/8	1/4(6,35)/3/8(9,52)
2,0 kW	CS-TZ20ZKEW	2,00	3,20	4x1,5	37/25/20	— 38/26/22	290x779x209/8	1/4(6,35)/3/8(9,52)
2,5 kW	CS-TZ25ZKEW	2,50	3,60	4x1,5	40/26/20	— 40/27/22	290x779x209/8	1/4(6,35)/3/8(9,52)
3,5 kW <sup>2)</sup>	CS-TZ35ZKEW	3,50	4,50	4x1,5	42/30/20	— 42/33/22	290x779x209/8	1/4(6,35)/3/8(9,52)
4,2 kW	CS-TZ42ZKEW	4,20	5,60	4x1,5	44/31/29	— 44/35/34	290x779x209/8	1/4(6,35)/1/2(12,70)
5,0 kW	CS-TZ50ZKEW	5,00	6,80	4x2,5	44/37/33	— 44/37/33	290x779x209/8	1/4(6,35)/1/2(12,70)
6,0 kW	CS-TZ60ZKEW	6,00	8,50	4x2,5	45/37/34	— 45/37/34	295x1040x244/12	1/4(6,35)/1/2(12,70)
7,1 kW	CS-TZ71ZKEW	7,10	8,70	4x2,5	47/38/35	— 47/38/35	295x1040x244/13	1/4(6,35)/5/8(15,88)



Optional wired remote controller. CZ-RD517C

INTERNET CONTROL: Optional.



Floor console <sup>5)</sup>	Indoor unit	Cooling capacity	Heating capacity	Connection in. / out.	Sound pressure <sup>6)</sup>		Dimension / Net weight	Piping diameter
					Cool — Heat (Hi/Lo/Q-Lo)	dB(A)		
2,0 kW	CS-MZ20UFEA	2,00	3,20	4x1,5	39/27/22	— 39/27/21	600x750x207/13	1/4(6,35)/3/8(9,52)
2,5 kW	CS-Z25UFEAW	2,50	3,60	4x1,5	40/27/22	— 40/27/21	600x750x207/13	1/4(6,35)/3/8(9,52)
3,5 kW <sup>2)</sup>	CS-Z35UFEAW	3,50	4,50	4x1,5	41/28/22	— 41/28/21	600x750x207/13	1/4(6,35)/3/8(9,52)
5,0 kW	CS-Z50UFEAW	5,00	5,30	4x1,5	44/33/29	— 48/35/31	600x750x207/13	1/4(6,35)/1/2(12,70)



Optional wired remote controller. CZ-RT6W or CZ-RTC6

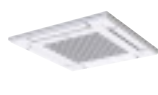

Panel (sold separately). CZ-KPY4

INTERNET CONTROL and BMS CONNECTIVITY: Optional.



4 Way 60x60 cassette*	Indoor unit (Panel CZ-KPY4)	Cooling capacity	Heating capacity	Connection in. / out.	Sound pressure <sup>7)</sup>		Dimension / Net weight		Piping diameter
					Cool — Heat (Hi/Lo/Q-Lo)	dB(A)	Indoor HxWxD	Panel HxWxD	
2,0 kW	S-M20PY3E	2,00	3,20	4x1,5	33/30/27	— 33/30/27	243x575x575/15	30x625x625/2,8	1/4(6,35)/1/2(12,70)
2,5 kW	S-25PY3E	2,50	3,60	4x1,5	33/30/27	— 33/30/27	243x575x575/15	30x625x625/2,8	1/4(6,35)/1/2(12,70)
3,5 kW <sup>2)</sup>	S-36PY3E	3,50	3,60	4x1,5	36/32/27	— 36/32/27	243x575x575/15	30x625x625/2,8	1/4(6,35)/1/2(12,70)
5,0 kW <sup>4)</sup>	S-50PY3E	5,00	6,80	4x1,5	41/36/29	— 41/36/29	243x575x575/15	30x625x625/2,8	1/4(6,35)/1/2(12,70)
6,0 kW	S-60PY3E	6,00	8,50	4x1,5	45/39/33	— 45/39/33	243x575x575/15	30x625x625/2,8	3/8(9,52)/5/8(15,88)

\* Compatible with Commercial control and connectivity accessories only. For detailed information go to the control systems section.



Optional wireless control kit. CZ-RL511D

INTERNET CONTROL and BMS CONNECTIVITY: Optional.



Low static pressure hide-away	Indoor unit	Cooling capacity	Heating capacity	Connection in. / out.	Sound pressure <sup>8)</sup>		Dimension / Net weight	Piping diameter
					Cool — Heat (Hi/Lo/Q-Lo)	dB(A)		
2,0 kW	CS-MZ20UD3EA	2,00	3,20	4x1,5	34/29/26	— 36/29/26	200x750x640/19	1/4(6,35)/3/8(9,52)
2,5 kW	CS-Z25UD3EAW	2,50	3,60	4x1,5	35/29/26	— 37/29/26	200x750x640/19	1/4(6,35)/3/8(9,52)
3,5 kW <sup>2)</sup>	CS-Z35UD3EAW	3,50	4,50	4x1,5	35/29/26	— 37/29/26	200x750x640/19	1/4(6,35)/3/8(9,52)
5,0 kW <sup>4)</sup>	CS-Z50UD3EAW	5,00	6,80	4x1,5	41/31/28	— 41/32/29	200x750x640/19	1/4(6,35)/1/2(12,70)
6,0 kW	CS-Z60UD3EAW	6,00	8,50	4x1,5	43/32/29	— 43/34/31	200x750x640/19	1/4(6,35)/1/2(12,70)

1) The sound pressure of the indoor unit shows the value measured at a position of 1 m in front of the main body and 0,8 m below the unit. The sound pressure is measured in accordance with JIS C 9612. Q-Lo: Quiet mode. Lo: The lowest set fan speed. 2) Heating capacity in combination with Free Multi outdoor units except with CU-Z235TBE. In this case, the heating capacity is 4,20 kW. 3) Heating capacity in combination with Free Multi outdoor units except with CU-Z250TBE. In this case, the heating capacity is 5,00 kW. 4) Heating capacity in combination with Free Multi outdoor units except with CU-Z235TBE. In this case, the heating capacity is 5,30 kW. 5) Compatible only with 2 ports R32 outdoor CU-Z235TBE / CU-Z241TBE / CU-Z250TBE. Minimum quantity of connection: 2 indoor units. 6) The sound pressure of the units shows the value measured at a position 1 m in front of the main body and 1 m above floor. The sound pressure is measured in accordance with JIS C 9612. Q-Lo: Quiet mode. Lo: The lowest set fan speed. 7) The sound pressure of the indoor unit shows the value measured at a position of 1,5 m below the unit. The sound pressure is measured in accordance with JIS C 9612. Q-Lo: Quiet mode. Lo: The lowest set fan speed. 8) The sound pressure of the indoor unit shows the value measured at a position of 1,5 m below the unit with 1 m duct on the suction side and 2 m duct on the discharge side. The sound pressure is measured in accordance with JIS C 9612.

# New Power Heat Multi system

# POWER HEAT

## Outdoor units Power Heat Multi system - R32

- Operation range down to -25 °C
- Equipped with base pan heater
- High energy efficiency: SCOP of 4,60
- Etherea indoor units with nanoe™ X technology to improve protection 24/7
- Indoor units with built-in Wi-Fi for internet and voice control

New 2024



## Tentative data

Outdoor unit			CU-2Z50ABEC	CU-3Z75ABEC
<b>Indoor nominal capacity</b>			<b>5,0 kW (2 room)</b>	<b>7,5 kW (3 room)</b>
Cooling capacity	Nominal (Min - Max)	kW	5,30 (2,10 - 7,50)	7,50 (2,10 - 8,80)
EER <sup>1)</sup>			4,21	3,87
<b>SEER <sup>2)</sup></b>			<b>8,00 A++</b>	<b>8,00 A++</b>
Pdesign (cooling)		kW	5,30	7,50
Input power	Nominal (Min - Max)	kW	1,26 (0,36 - 2,06)	1,94 (0,38 - 2,45)
Heating capacity	Nominal (Min - Max)	kW	6,40 (1,70 - 8,70)	8,60 (1,70 - 10,60)
COP <sup>1)</sup>			4,18	4,26
Heating capacity at -15 °C	Max	kW	5,90	6,30
Heating capacity at -25 °C	Max	kW	3,90	4,30
<b>SCOP <sup>2)</sup></b>			<b>4,40 A+</b>	<b>4,60 A++</b>
Pdesign at -10 °C		kW	5,10	5,60
Input power	Nominal (Min - Max)	kW	1,53 (0,32 - 2,44)	2,02 (0,32 - 2,92)
Current	Heat / Cool	A	6,80 / 5,70	8,80 / 8,50
Power supply		V	230	230
Sound pressure <sup>3)</sup>	Heat / Cool (Hi)	dB(A)	49 / 49	53 / 49
Dimension <sup>4)</sup>	HxWxD	mm	795 x 875 x 320	795 x 875 x 320
Net weight		kg	58	62
Piping diameter	Liquid	Inch (mm)	1/4 (6,35)	1/4 (6,35)
	Gas	Inch (mm)	3/8 (9,52)	3/8 (9,52)
Pipe length range total		m	50	60
Pipe length range to one unit		m	3 ~ 25	3 ~ 25
Elevation difference (in / out)		m	15	15
Pre-charged pipe length		m	30	30
Additional gas amount		g/m	20	20
Refrigerant (R32) / CO <sub>2</sub> Eq.		kg / T	1,92 / 1,296	2,42 / 1,634
Operating range	Heat Min ~ Max	°C	-25 ~ +24	-25 ~ +24
	Cool Min ~ Max	°C	-10 ~ +46	-10 ~ +46

1) EER and COP calculation is based in accordance to EN 14511. 2) Energy Label Scale from A+++ to D. 3) The sound pressure of the units shows the value measured of a position 1 m in front and 1 m in rear side of the main body. The sound pressure is measured in accordance with JIS C 9612. 4) Add 70 or 95 mm for piping port.



## Possible outdoor / indoor units combinations

Rooms	Outdoor unit	Indoor capacity connected	Wall-mounted Etherea			
			20	25	35	50
2	CU-2Z50ABEC	0,85 ~ 3,6 kW	•	•	•	•
3	CU-3Z75ABEC	0,85 ~ 7,5 kW	•	•	•	•

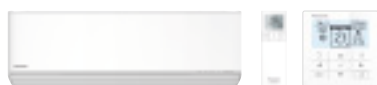

Optional wired remote controller. CZ-RD517C



Wall-mounted Etherea	Indoor unit	Cooling capacity	Heating capacity	Connection in. / out.	Sound pressure <sup>1)</sup>	Dimension / Net weight	Piping diameter
					Cool — Heat (Hi/Lo/Q-Lo)	H x W x D	Liquid / Gas
		kW	kW	mm <sup>2</sup>	dB(A)	mm / kg	Inch (mm)
2,0 kW	CS-Z20ZKEW	2,00	3,20	4x1,5	37 / 26 / 21 — 38 / 27 / 21	295 x 870 x 229 / 10	1/4 (6,35) / 3/8 (9,52)
2,5 kW	CS-Z25ZKEW	2,50	3,60	4x1,5	41 / 27 / 21 — 41 / 29 / 21	295 x 870 x 229 / 10	1/4 (6,35) / 3/8 (9,52)
3,5 kW	CS-Z35ZKEW	3,50	4,50	4x1,5	44 / 30 / 21 — 45 / 35 / 21	295 x 870 x 229 / 11	1/4 (6,35) / 3/8 (9,52)
5,0 kW	CS-Z50ZKEW	5,00	6,80	4x2,5	44 / 39 / 32 — 46 / 39 / 32	295 x 1040 x 244 / 12	1/4 (6,35) / 1/2 (12,70)

1) The sound pressure of the indoor unit shows the value measured of a position of 1 m in front of the main body and 0,8 m below the unit. The sound pressure is measured in accordance with JIS C 9612. Q-Lo: Quiet mode. Lo: The lowest set fan speed.

# Multi TZ system

## Outdoor units Multi TZ · R32

- Up to 3 indoor units with a single outdoor unit
- Up to 3 rooms with individual control
- High energy efficiency class A++ SEER
- Flexible installation, compact units and large connection distance
- Indoor units compatible with internet and voice control



Outdoor unit			CU-2TZ41TBE	CU-2TZ50TBE	CU-3TZ52TBE
<b>Indoor nominal capacity (Min - Max)</b>			<b>3,2 ~ 6,0 kW</b>	<b>3,2 ~ 7,7 kW</b>	<b>4,5 ~ 9,5 kW</b>
Cooling capacity	Nominal (Min - Max)	kW	4,10 (1,50 - 4,70)	5,00 (1,50 - 5,40)	5,20 (1,80 - 6,60)
EER <sup>1)</sup>	Nominal (Min - Max)	W/W	4,14 (5,56 - 3,41)	3,85 (5,56 - 3,33)	4,52 (3,67 - 5,00)
<b>SEER <sup>2)</sup></b>			<b>7,10 A++</b>	<b>7,00 A++</b>	<b>7,60 A++</b>
Pdesign (cooling)		kW	4,10	5,00	5,20
Input power	Nominal (Min - Max)	kW	0,99 (0,27 - 1,38)	1,30 (0,27 - 1,62)	1,15 (0,36 - 1,80)
Annual energy consumption <sup>3)</sup>		kWh/a	202	250	239
Heating capacity	Nominal (Min - Max)	kW	4,40 (1,10 - 6,30)	5,70 (1,10 - 6,40)	6,80 (1,60 - 7,50)
Heating capacity at -7 °C		kW	3,75	3,80	—
COP <sup>1)</sup>	Nominal (Min - Max)	W/W	4,44 (5,00 - 3,54)	4,35 (5,00 - 3,62)	4,28 (3,87 - 5,00)
<b>SCOP <sup>2)</sup></b>			<b>4,30 A+</b>	<b>4,20 A+</b>	<b>4,20 A+</b>
Pdesign at -10 °C		kW	3,50	4,50	5,00
Input power	Nominal (Min - Max)	kW	0,99 (0,22 - 1,78)	1,31 (0,22 - 1,77)	1,59 (0,32 - 1,94)
Annual energy consumption <sup>3)</sup>		kWh/a	1139	1500	1667
Current	Cool / Heat	A	4,60 / 4,60	6,00 / 6,00	5,30 / 7,30
Power supply		V	230	230	230
Sound pressure <sup>4)</sup>	Cool / Heat (Hi)	dB(A)	48 / 50	50 / 52	48 / 48
Dimension <sup>5)</sup>	H x W x D	mm	542 x 780 x 289	542 x 780 x 289	795 x 875 x 320
Net weight		kg	35	35	71
Piping diameter	Liquid	Inch (mm)	1/4 (6,35)	1/4 (6,35)	1/4 (6,35)
	Gas	Inch (mm)	3/8 (9,52)	3/8 (9,52)	3/8 (9,52)
Pipe length range total		m	6 ~ 30	6 ~ 30	6 ~ 50
Pipe length range to one unit		m	3 ~ 20	3 ~ 20	3 ~ 25
Elevation difference (in / out)		m	10	10	15
Pre-charged pipe length		m	20	20	30
Additional gas amount		g/m	15	15	20
Refrigerant (R32) / CO <sub>2</sub> Eq.		kg / T	0,9 / 0,6075	0,9 / 0,6075	2,1 / 1,4175
Operating range	Cool Min ~ Max	°C	-10 ~ +46	-10 ~ +46	-10 ~ +46
	Heat Min ~ Max	°C	-15 ~ +24	-15 ~ +24	-15 ~ +24

1) EER and COP calculation is based in accordance to EN 14511. 2) Energy Label Scale from A+++ to D. 3) The annual energy consumption is calculated in accordance to EU/626/2011. 4) The sound pressure of the units shows the value measured of a position 1 m in front and 1 m in rear side of the main body. The sound pressure is measured in accordance with JIS C 9612. 5) Add 70 or 95 mm for piping port.



## Possible outdoor / indoor units combinations

Rooms	Outdoor unit	Indoor capacity connected (Min - Max)	Wall-mounted TZ super-compact					
			16	20	25	35	42	50
2	CU-2TZ41TBE	3,2 ~ 6,0 kW	•	•	•	•		
	CU-2TZ50TBE	3,2 ~ 7,7 kW	•	•	•	•	•	•
3	CU-3TZ52TBE	4,5 ~ 9,5 kW	•	•	•	•	•	•

Minimum quantity of connection: 2 indoor units.



Optional wired remote controller. CZ-RD517C



Wall-mounted TZ super-compact	Indoor unit	Cooling capacity	Heating capacity	Connection in. / out.	Sound pressure <sup>1)</sup>		Dimension / Net weight	Piping diameter	
					Cool — Heat (Hi/Lo/Q-Lo)			Liquid / Gas	
					dB(A)		mm / kg		Inch (mm)
1,6 kW	CS-MTZ16ZKE	1,60	2,60	4x1,5	38 / 27 / 22 — 39 / 28 / 24		290 x 779 x 209 / 8		1/4 (6,35) / 3/8 (9,52)
2,0 kW	CS-TZ20ZKEW	2,00	3,20	4x1,5	37 / 25 / 20 — 38 / 26 / 22		290 x 779 x 209 / 8		1/4 (6,35) / 3/8 (9,52)
2,5 kW	CS-TZ25ZKEW	2,50	3,60	4x1,5	40 / 26 / 20 — 40 / 27 / 22		290 x 779 x 209 / 8		1/4 (6,35) / 3/8 (9,52)
3,5 kW	CS-TZ35ZKEW	3,50	4,50	4x1,5	42 / 30 / 20 — 42 / 33 / 22		290 x 779 x 209 / 8		1/4 (6,35) / 3/8 (9,52)
4,2 kW	CS-TZ42ZKEW	4,20	5,60	4x1,5	44 / 31 / 29 — 44 / 35 / 34		290 x 779 x 209 / 8		1/4 (6,35) / 1/2 (12,70)
5,0 kW	CS-TZ50ZKEW	5,00	6,80	4x2,5	44 / 37 / 33 — 44 / 37 / 33		290 x 779 x 209 / 8		1/4 (6,35) / 1/2 (12,70)

1) The sound pressure of the indoor unit shows the value measured of a position of 1 m in front of the main body and 0,8 m below the unit. The sound pressure is measured in accordance with JIS C 9612. Q-Lo: Quiet mode. Lo: The lowest set fan speed.

Rating conditions: Cooling indoor 27 °C DB / 19 °C WB. Cooling outdoor 35 °C DB / 24 °C WB. Heating indoor 20 °C DB. Heating outdoor 7 °C DB / 6 °C WB. (DB: Dry Bulb; WB: Wet Bulb). Specifications subject to change without notice. For detailed information about ErP / Energy Labelling, please visit our websites [www.aircon.panasonic.eu](http://www.aircon.panasonic.eu) or [www.ptc.panasonic.eu](http://www.ptc.panasonic.eu).

# RAC Solo, the compact air conditioner without outdoor unit

A high-efficiency RAC Solo with a hyper-compact design that minimises aesthetic impact. Just 16,5 cm deep, easy to install and with DC Inverter technology to optimise performance.



## Seamless integration, indoors and outdoors

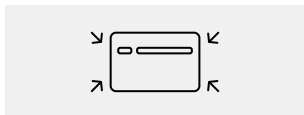

**Slim and compact full metal body.**  
Only 16,5 cm deep (indoor).

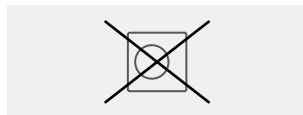

**No outdoor unit.**  
Just two 162 mm holes\*.  
\* 202 mm for the biggest capacity.



**Easy to install.**  
Stand-alone unit with no refrigerant connections.

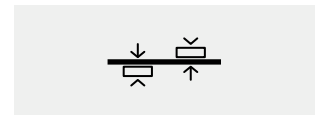

**Self-closing grille.**  
Open only during operation.

## Easy and flexible installation, without outdoor unit

The RAC Solo range offers great installation flexibility as it is a stand-alone unit with no refrigerant connections during installation. The outdoor unit is replaced by two holes in the wall.

All you need is a perimeter wall, to exchange air with the outside. The unit can be placed high on the wall or low on the floor.

Down installation.

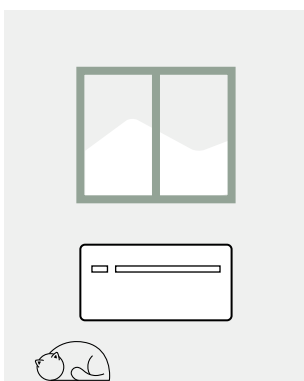

Overhead installation.

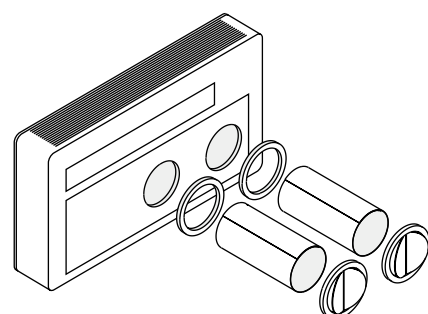
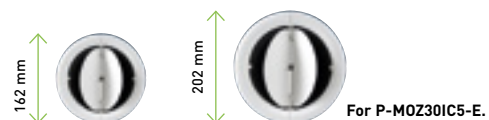
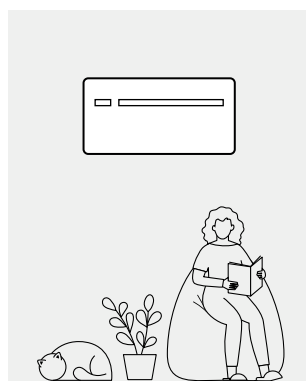

## RAC Solo - R290 / R32

- Slim and compact, only 165 mm deep
- No outdoor unit
- Heating and cooling or cooling only modes available
- Dual power mode, the desired temperature in the shortest possible time
- DC Inverter technology
- No frost system, with preheated condenser water tray
- Easy and flexible installation



Kit matt white			P-MOG16IC5-E	P-MOZ20IC5-E	P-MOZ25IC5-E	P-MOZ30IC5-E
Cooling capacity	Nominal (Min - Max)	kW	1,73 [0,70 - 2,35]	2,09 [0,83 - 2,64]	2,33 [0,92 - 3,10]	2,87 [1,40 - 3,50]
EER <sup>1)</sup>		W/W	3,01	3,29	3,25	2,74
<b>SEER <sup>2)</sup></b>			<b>4,60 B</b>	<b>4,70 A</b>	<b>4,60 B</b>	<b>4,10 C</b>
Input power		kW	0,57	0,64	0,73	1,04
Heating capacity	Nominal (Min - Max)	kW	1,71 [0,75 - 2,40]	2,08 [0,71 - 2,64]	2,31 [0,79 - 3,05]	2,75 [1,35 - 3,50]
Heating capacity at -7 °C		kW	1,13	1,37	1,52	1,81
COP <sup>1)</sup>		W/W	3,15	3,31	3,28	3,12
<b>SCOP <sup>2)</sup></b>			<b>3,70 A</b>	<b>3,80 A</b>	<b>3,70 A</b>	<b>3,40 A</b>
Input power		kW	0,54	0,63	0,71	0,88
Power supply		V	230	230	230	230
Maximum current		A	3,90	4,10	4,60	6,30
Air flow	Max / Average / Min	m <sup>3</sup> /min	6,0/5,0/4,0	6,3/5,2/4,3	6,7/5,3/4,5	7,5/5,8/5,0
External air flow	Max / Average / Min	m <sup>3</sup> /min	7,2/6,0/5,3	7,7/6,3/5,5	8,0/6,5/5,7	9,2/7,7/6,7
Moisture removal volume		L/h	0,7	0,8	0,9	1,2
Sound pressure <sup>3)</sup>	Hi / Lo / Q-Lo	dB(A)	39/29/27	39/30/26	41/31/27	43/33/29
Outside sound pressure <sup>3)</sup>	Hi / Lo	dB(A)	49/36	49/36	51/38	53/40
Refrigerant / charge		kg	R290 / 0,14	R32 / 0,5	R32 / 0,5	R32 / 0,5
Dimension	HxWxD	mm	549x810x165	549x1010x165	549x1010x165	549x1010x165
Net weight		kg	38	41	41	41
Wall hole diameter		mm	162	162	162	202
Distance between wall holes		mm	293	293	293	293
Operating range	Cool Min ~ Max	°C	-5 ~ +43	-5 ~ +43	-5 ~ +43	-5 ~ +43
	Heat Min ~ Max	°C	-15 ~ +18	-15 ~ +18	-15 ~ +18	-15 ~ +18

1) EER and COP calculation is based in accordance to EN 14511. 2) Energy Label Scale from A+++ to D. 3) The sound pressure shows the value measured at 2 m, according to ISO 7779.

Accessories	
<b>PCZ-GB0738</b>	Kit of external aluminium grids with fixed fins (162 mm holes)
<b>PCZ-GB1091</b>	Kit of external aluminium grids with fixed fins (202 mm holes)
<b>PCZ-GB0755</b>	Insect protection kit (1 metal mesh, 1 grid in metal wire and fixing accessories)
<b>PCZ-L00773</b>	Side exit formwork for corner installation (right-hand outlet)

\* Check availability.

Accessories	
<b>PCZ-L00774</b>	Side exit formwork for corner installation (left-hand outlet)
<b>PCZ-GB0737</b>	Bottom cover kit for overhead installation for P-MOZ20/25/30IC5-E
<b>PCZ-GB1105</b>	Bottom cover kit for overhead installation for P-MOG16IC5-E
<b>PCZ-GB1119</b>	Condensate drain pipe heater kit*



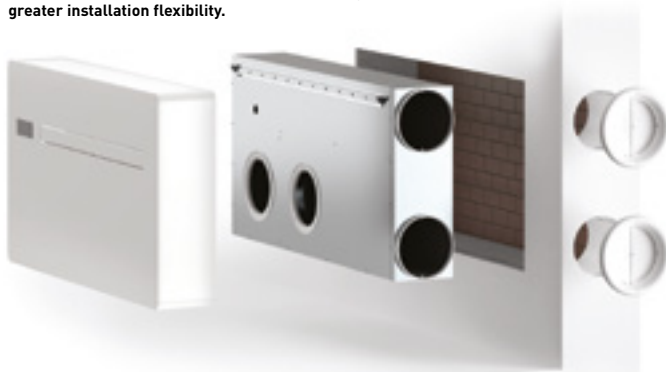

































The side installation kit, which must be embedded in the wall, allows the air flow to be redirected sideways for greater installation flexibility.



R290: For P-MOG16IC5-E. R32: For P-MOZ20IC5-E, P-MOZ25IC5-E and P-MOZ30IC5-E.

Rating conditions: Cooling indoor 27 °C DB / 19 °C WB. Cooling outdoor 35 °C DB / 24 °C WB. Heating indoor 20 °C DB. Heating outdoor 7 °C DB / 6 °C WB. (DB: Dry Bulb; WB: Wet Bulb). Specifications subject to change without notice. For detailed information about ErP / Energy Labelling, please visit our websites [www.aircon.panasonic.eu](http://www.aircon.panasonic.eu) or [www.ptc.panasonic.eu](http://www.ptc.panasonic.eu).

# Single split feature overview

Models	Wall-mounted Heatcharge VZ · R32	Wall-mounted Etherea · R32	Wall-mounted TZ super-compact · R32	Wall-mounted BZ super-compact · R32	Wall-mounted UZ super-compact · R32	Floor console · R32	Low static pressure hide-away · R32
 Refrigerant R32	✓	✓	✓	✓	✓	✓	✓
 Econavi. Sunlight sensor	✓						
 Inverter+ system	✓	✓				✓	
 Inverter system			✓	✓	✓		✓
 R2 rotary compressor	✓	✓	✓	✓	✓	✓	✓
 nanoe X Generator	✓ nanoe™	✓ Mark 3	✓ Mark 1			✓ Mark 1	
 PM2,5 Filter				✓			
 Dust collection filter					✓		
 Antiallergy properties	✓	✓	✓			✓	
 Super Quiet <sup>1)</sup>	✓	✓ 19 dB(A) for 2,0, 2,5 and 3,5 kW	✓ 20 dB(A) for 2,0, 2,5 and 3,5 kW	✓ 20 dB(A) for 2,5 and 3,5 kW	✓ 20 dB(A) for 2,5 and 3,5 kW	✓ 20 dB(A) for 2,5 and 3,5 kW	
 Inside cleaning		✓					
 Mild Dry cooling		✓					
 Aerowings		✓	✓	✓	✓		
 Down to -10 °C in cooling only	✓	✓	✓	✓	✓	✓	✓
 Down to -15 °C in heating mode	✓ -35 °C <sup>2)</sup>	✓ -20 °C	✓	✓	✓	✓	✓
 Summer House	✓						
 R410A/R22 Renewal	✓	✓	✓	✓	✓	✓	✓
 Odour-removing function	✓	✓	✓	✓	✓	✓	✓
 Removable, washable panel	✓	✓	✓	✓	✓	✓	
 Powerful mode	✓	✓	✓	✓	✓	✓	✓
 Soft dry operation mode	✓	✓	✓	✓	✓	✓	✓
 Personal air flow creation	✓	✓	✓ For 6,0 and 7,1 kW				
 Automatic vertical air flow control			✓ For 2,0, 2,5, 3,5, 4,2 and 5,0 kW	✓	✓	✓	
 Manual horizontal air flow control			✓ For 2,0, 2,5, 3,5, 4,2 and 5,0 kW	✓	✓	✓	
 Auto mode	✓	✓	✓	✓	✓	✓	✓
 Hot start mode	✓	✓	✓	✓	✓	✓	✓
 Real time clock with dual ON / OFF timer	✓	✓	✓	✓	✓	✓	
 Weekly timer							✓
 LCD infrared remote controller	✓	✓	✓	✓	✓	✓	
 Automatic restart	✓	✓	✓	✓	✓	✓	✓
 Long piping	✓ 15 m	✓ 15 m, 30 m (5,0 and 7,1 kW)	✓ 15 m, 20 m (5,0 kW), 30 m (7,1 and 6,0 kW)	✓ 15 m, 30 m (6,0 kW)	✓ 15 m	✓ 20 m, 30 m (5,0 kW)	✓ 20 m, 30 m (5,0 and 6,0 kW)
 Top-Panel maintenance access	✓	✓	✓	✓	✓	✓	✓
 Self-diagnosis function	✓	✓	✓	✓	✓	✓	✓
 RAC interface adapter for integration into S-Link	✓	✓	✓	✓	✓	✓	✓
 Wi-Fi control	✓	✓ Built-in	✓ Built-in	✓	✓	✓	✓
 Easy control by BMS	✓	✓	✓	✓	✓	✓	✓
 Warranty on the compressor	✓	✓	✓	✓	✓	✓	✓

1) At the lowest fan speed. 2) Tested by 3rd party laboratory, SP, according to EN 14511:2013 and SP Method 1721, this temperature is not guaranteed by Factory.



# Features explained

## Energy saving

**R32 Refrigerant R32.**  
Our heat pumps containing R32 refrigerant show a drastic reduction in the value of Global Warming Potential (GWP). An important step to reduce greenhouse gases. R32 is also a component refrigerant, making it easy to recycle.

**Inverter Plus system.**  
Inverter Plus system classification highlights Panasonic's highest performing systems.

**Panasonic R2 rotary compressor.**  
Designed to withstand extreme conditions, it delivers high performance and efficiency.

**Econavi. Sunlight sensor.**  
Sunlight Sensor technology can detect and reduce the waste of energy by optimising air conditioner operation according to room conditions. With just one touch of a button, you can save energy.

**Inverter.**  
The Inverter range provides greater efficiency and comfort. Provides more precise temperature control, without highs and lows, and keeps the ambient temperature constant with lower energy consumption and a significant reduction in noise and vibration levels.

## High performance and indoor air quality

**nanoe™ X.**  
Technology with the benefits of hydroxyl radicals has the capacity to inhibit pollutants, viruses, and bacteria to clean and deodorise.

**Summer House.**  
This innovative function keeps the house at 8/10 or 8/15 °C to avoid freezing pipes during the winter. This function is beneficial for summer or weekend homes.

**Auto mode.**  
Automatically switches the current operation mode to heating or cooling mode necessary to keep the temperature at a constantly comfortable level based on the temperature of the room. In case of multi split installation the function is limited to first unit working and logic of switching is different considering also the outdoor temperature.

**PM2.5 filter.**  
This filter can capture airborne particulate matter (PM2.5), including hazardous pollutants, as well as house dust and pollen.

**R22/R410A Renewal.**  
The Panasonic renewal system allows good quality existing R410A or R22 pipe work to be re-used whilst installing high efficiency R32 systems.

**Dust collection filter.**  
This filter collects and retains particles suspended in the air, resulting in cleaner air in the room.

**Odour-removing function.**  
Allows the exchanger to be cleaned, preventing possible odours. While this function is connected, the fan also remains OFF momentarily to avoid unpleasant odours while the exchanger is being cleaned.

**Antiallergy properties.**  
System is equipped with antiallergy properties filter.

**Inside cleaning.**  
This function works to dry the inside of the indoor unit with nanoe™ X. It can inhibit certain adhered bacteria, viruses and mould with up to 99% efficiency.

**Removable, washable panel.**  
The front panel is easy to keep clean. It can be removed quickly in one single step and can be washed in water. A clean front panel ensures smoother, more efficient operation, which can save energy.

**Super Quiet.**  
Thanks to its latest generation compressor and its twin blade fan, our outdoor unit is one of the most silent on the market. The indoor unit emits an almost imperceptible 18 dB(A).

**Powerful mode.**  
The rapid and effective powerful mode is ideal for when you come home on the hottest or coldest days. It works at maximum power to reach the desired temperature in just 15 minutes.

**Mild Dry cooling.**  
Fine control helps prevent a rapid decrease in room humidity while maintaining the set temperature. Maintains an RH\* up to 10% higher than cooling operation (\*RH: Relative Humidity). Ideal when sleeping with the air conditioner on.

**Soft Dry operation mode.**  
The soft dry mode eliminates excess moisture with a soft breeze and provides a sense of wellbeing without much change in temperature.

**Aerowings.**  
Panasonic's Aerowings feature incorporates two blades that concentrate the air flow to cool or heat in the shortest possible time by distributing the air evenly throughout the room.

**Personal air flow creation.**  
Permits the air direction to be adjusted vertically and horizontally. This feature can be conveniently selected by remote controller.

**Down to -10 °C in cooling mode.**  
The air conditioner works in cooling mode when the outdoor temperature of -10 °C.

**Automatic vertical air flow control.**  
The flap swings up and down automatically. The flow can also be set at a fixed angle with the remote controller.

**Down to -15 °C in heating mode.**  
The air conditioner works in heat pump mode when the outdoor temperature is as low as -15 °C.

**Manual horizontal air flow control.**

## High connectivity

**Domestic integration to S-Link - CZ-CAPRA1.**  
Can connect RAC range to S-Link. Full control is now possible.









**Wi-Fi control.**  
The Panasonic Comfort Cloud App allows users to conveniently manage and monitor Panasonic residential heat pumps from a mobile device, anytime, anywhere.

**BMS connectivity.**  
The communication port can be integrated into the indoor unit and provides easy connection to, and control of, your Panasonic air conditioner to your home or Building Management System.





**5 Years compressor warranty.**  
We guarantee the outdoor unit compressors in the entire range for five years.

# Accessories and control

## Connectivity

 <p><b>Wi-Fi adapter for smart control via Panasonic Comfort Cloud App.</b></p> <p>----- CZ-TACG1</p>	 <p><b>Interface adapter for integration into S-Link, plus external input and alarm/status output.</b></p> <p>----- CZ-CAPRA1</p>	 <p><b>KNX interface. Can be used with all models which have a CN-CNT connector (Intesis).</b></p> <p>----- PAW-AC-KNX-1i</p>
 <p><b>Modbus interface. Can be used with all models which have a CN-CNT connector (Intesis).</b></p> <p>----- PAW-AC-MBS-1</p>	 <p><b>BACnet interface. Can be used with all models which have a CN-CNT connector (Intesis).</b></p> <p>----- PAW-AC-BAC-1</p>	 <p><b>KNX interface. Can be used with all models which have a CN-CNT connector (Airzone).</b></p> <p>----- PAW-AZAC-KNX-1</p>
 <p><b>Modbus interface. Can be used with all models which have a CN-CNT connector (Airzone).</b></p> <p>----- PAW-AZAC-MBS-1</p>	 <p><b>BACnet interface. Can be used with all models which have a CN-CNT connector (Airzone).</b></p> <p>----- PAW-AZAC-BAC-1</p>	 <p><b>This interface can be used with all models which have a CN-RMT connector.</b></p> <p>----- PAW-AC-DIO</p>

## Individual controls

 <p><b>Wired remote controller for wall-mounted and floor console.</b></p> <p>----- CZ-RD517C</p>	 <p><b>Infrared remote controller Sky Remote. 2 m cable length of infrared receiver for hide-away.</b></p> <p>----- CZ-RL511D</p>	 <p><b>CONEX wired remote controller (non-wireless) for 4 way 60x60 cassette - PY3, white.</b></p> <p>----- CZ-RTC6W</p>	 <p><b>CONEX wired remote controller (non-wireless) for 4 way 60x60 cassette - PY3, black.</b></p> <p>----- CZ-RTC6</p>
--	--	--	--

## Panel

 <p><b>Panel for 4 way 60x60 cassette - PY3.</b></p> <p>----- CZ-KPY4</p>
---

## Pipe reducer

 <p><b>Reduces the connection size on the indoor unit from 1/2" to 3/8".</b></p> <p>----- CZ-MA1PA</p>	 <p><b>Increases the connection size on the outdoor unit from 3/8" to 1/2".</b></p> <p>----- CZ-MA2PA</p>	 <p><b>Reduces the connection size on the indoor unit from 5/8" to 1/2".</b></p> <p>----- CZ-MA3PA</p>
--	--	--

## RAC Solo accessories



**Kit of external aluminium grids with fixed fins (162 mm holes).**

-----  
PCZ-GB0738

**Kit of external aluminium grids with fixed fins (202 mm holes).**

-----  
PCZ-GB1091

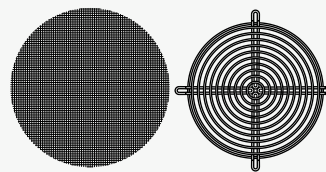

**Insect protection kit (1 metal mesh, 1 grid in metal wire and fixing accessories).**

-----  
PCZ-GB0755



**Side exit formwork for corner installation (right-hand outlet).**

-----  
PCZ-L00773

**Side exit formwork for corner installation (left-hand outlet).**

-----  
PCZ-L00774

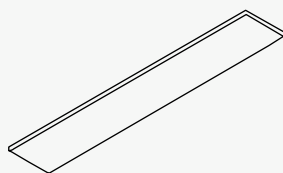

**Bottom cover kit for overhead installation for P-MOZ20/25/30IC5-E.**

-----  
PCZ-GB0737

**Bottom cover kit for overhead installation for P-MOG16IC5-E.**

-----  
PCZ-GB1105

**Condensate drain pipe heater kit\*.**

-----  
PCZ-GB1119

\* Check availability.

# Dimensions

## Domestic

Heatcharge VZ	→ 53
Etherea	→ 54
TZ super-compact	→ 56
BZ super-compact	→ 58
UZ super-compact	→ 59
Floor console	→ 60
Low static pressure hide-away	→ 61
Indoor unit Free Multi system Z - 4 Way 60x60 cassette	→ 62
Outdoor units Free Multi System Z	→ 63
Outdoor units Multi Wall TZ	→ 64

Wall-mounted Heatcharge VZ.

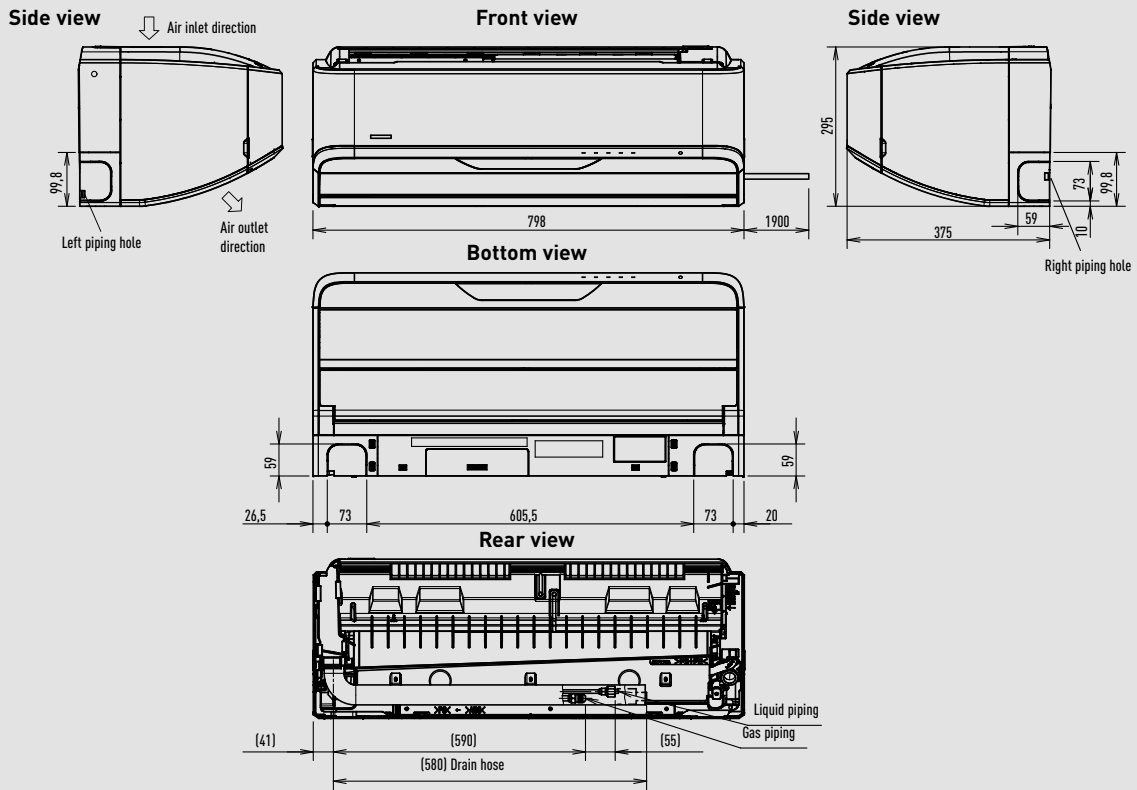

Relative position between the indoor unit and the installation plate

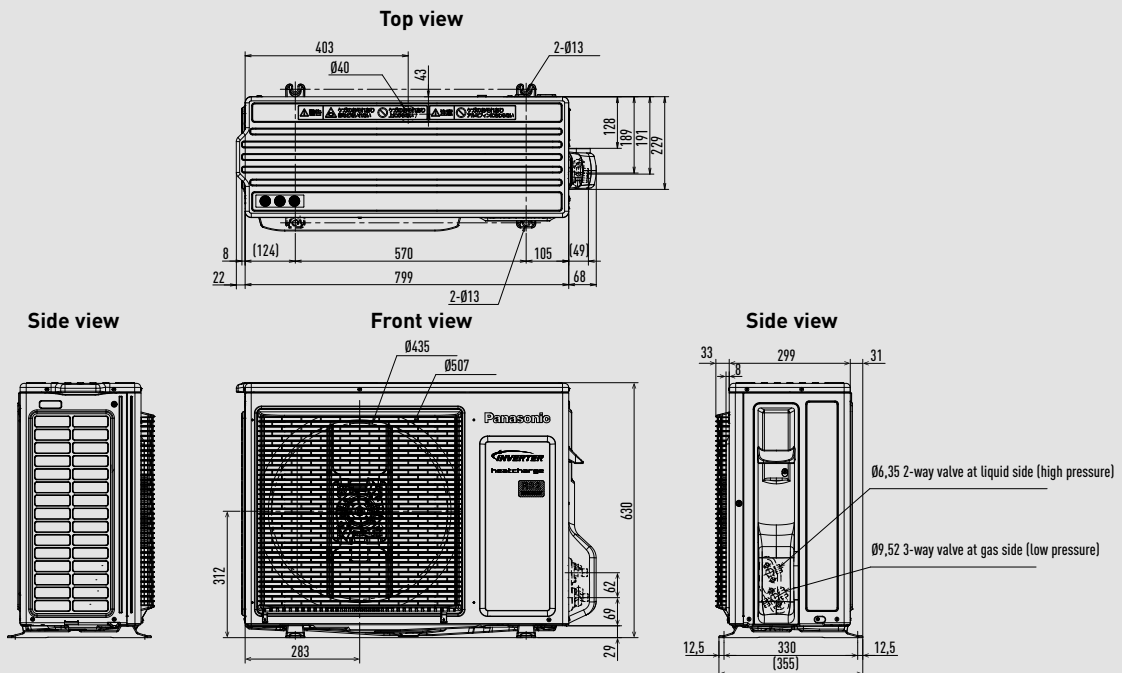
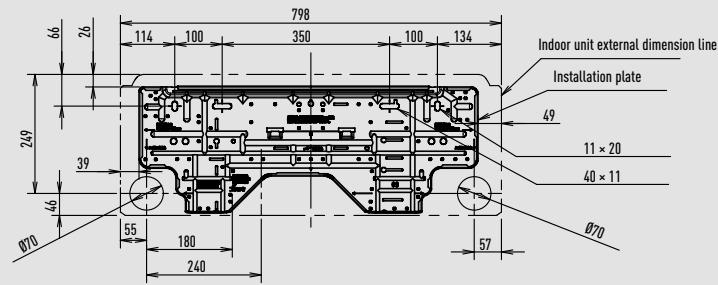

Wall-mounted Etherea (from 1,6 to 4,2 kW).

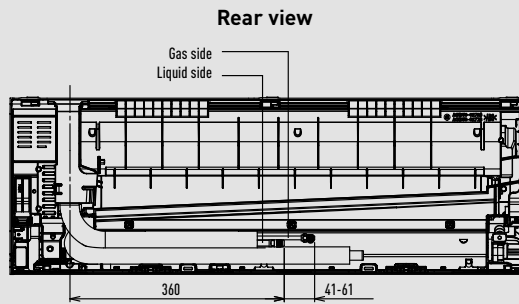
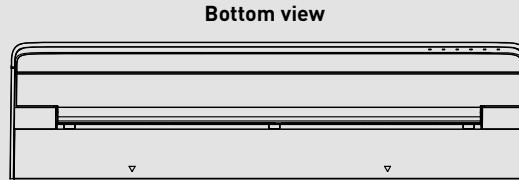
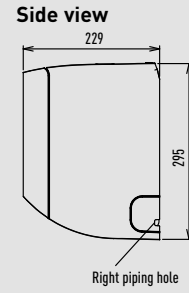
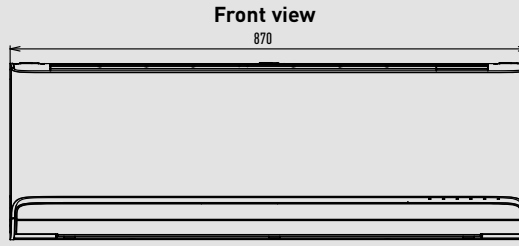
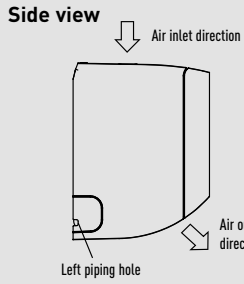

Relative position between the indoor unit and the installation plate

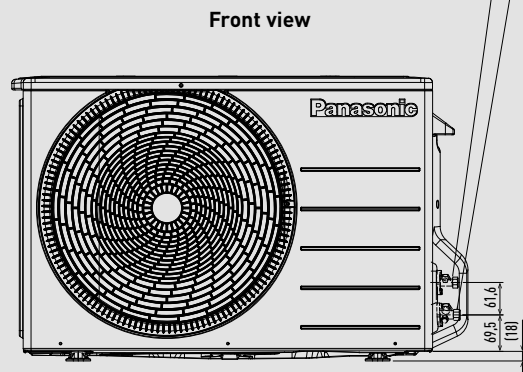
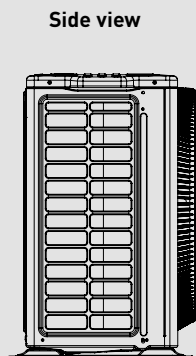
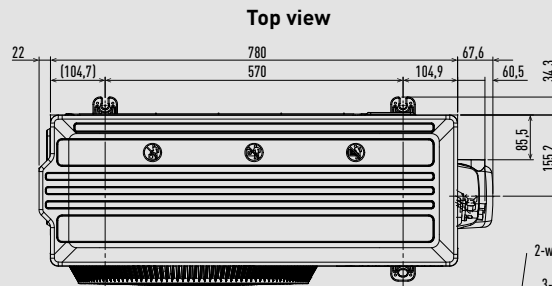
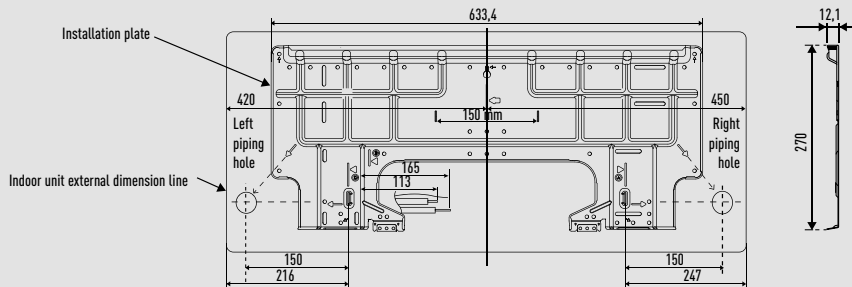

2-way valve at liquid side (high pressure)  
3-way valve at gas side (low pressure)

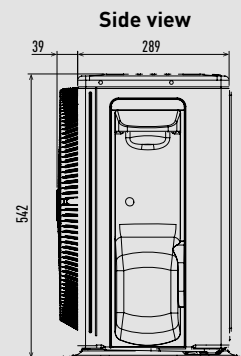

Wall-mounted Etherea (5,0 and 7,1 kW).

Side view

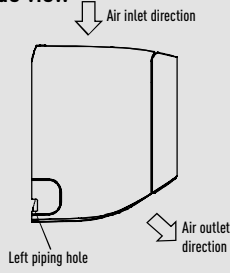

Front view

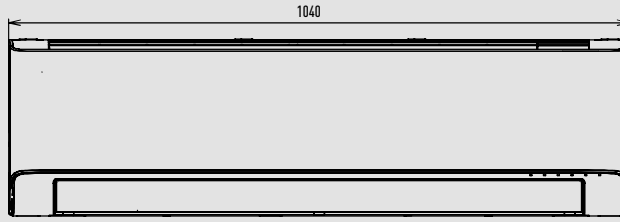

Side view

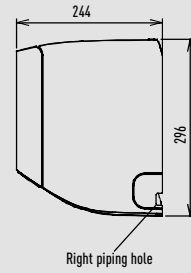

Bottom view

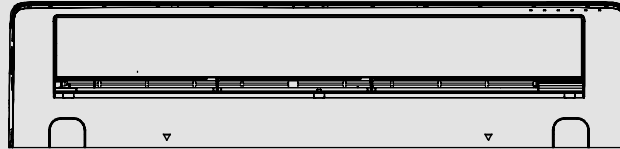

Rear view

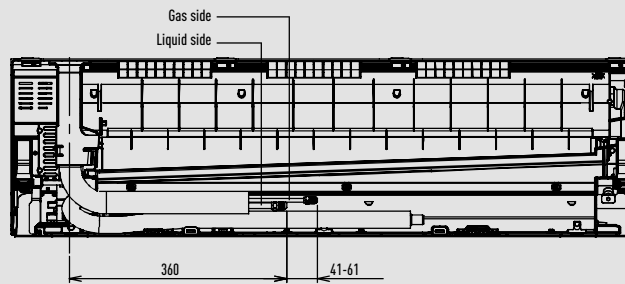

Relative position between the indoor unit and the installation plate

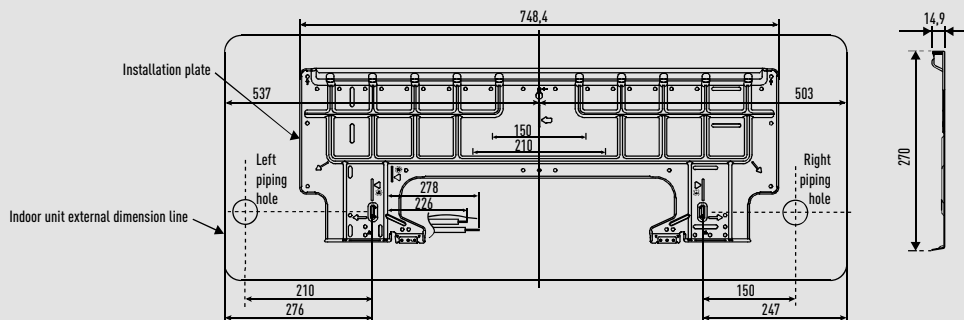

Top view

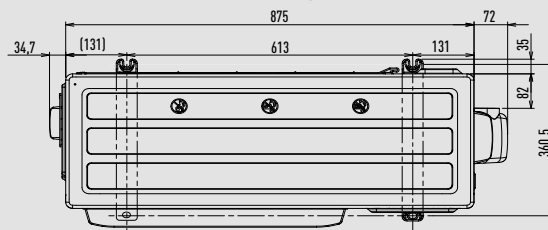

Side view

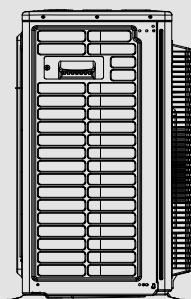

Front view

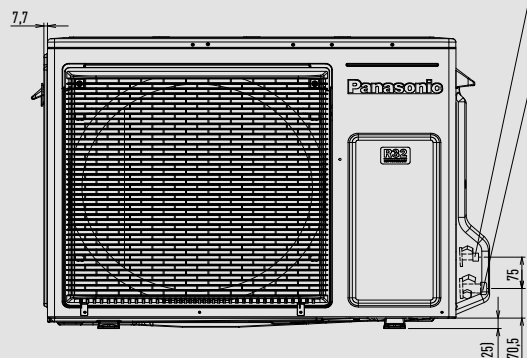

Side view

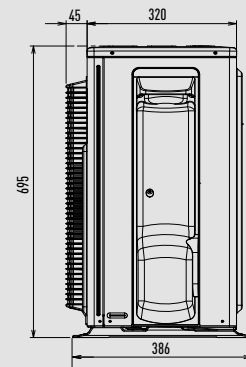

2-way valve at liquid side (high pressure)

3-way valve at gas side (low pressure)

Wall-mounted TZ super-compact (from 1,6 to 5,0 kW).

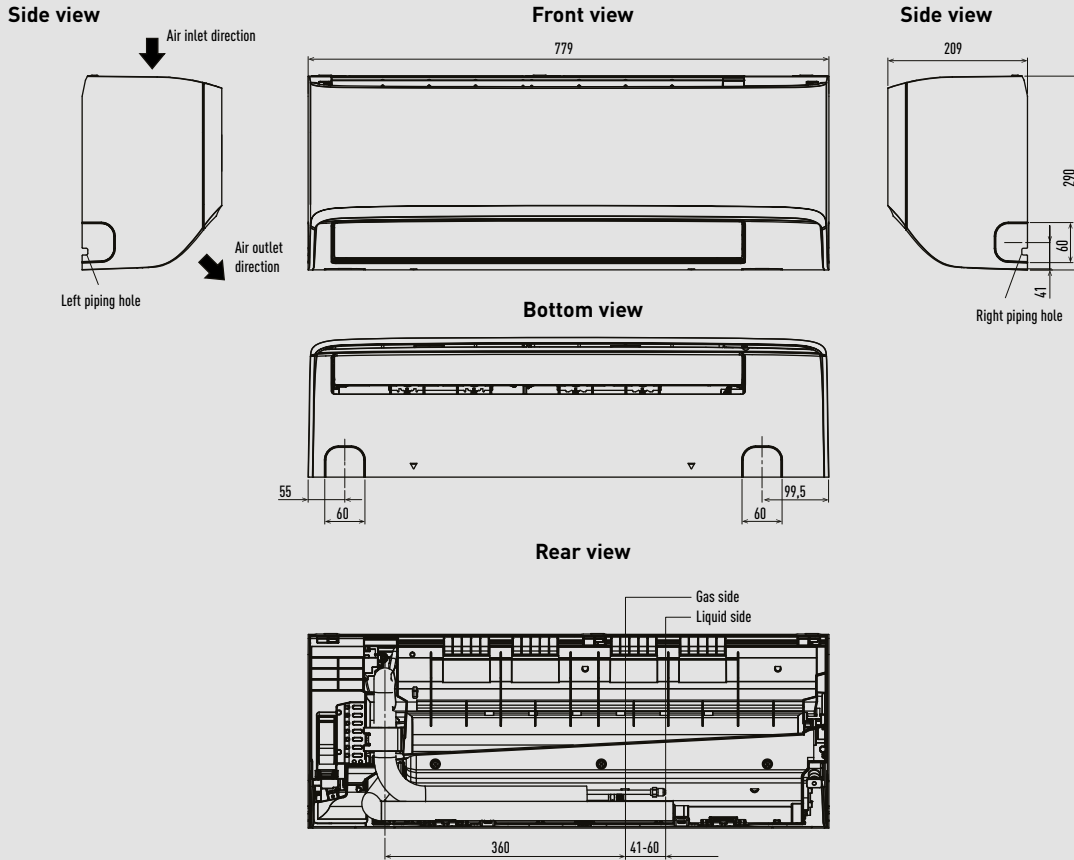

Relative position between the indoor unit and the installation plate

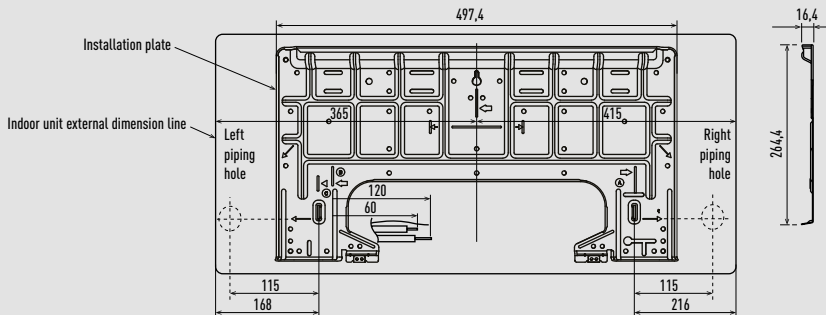

CU-TZ20ZKE / CU-TZ25ZKE / CU-TZ35ZKE / CU-TZ42ZKE

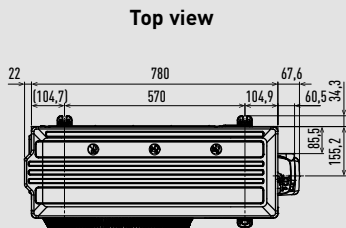

CU-TZ50ZKE

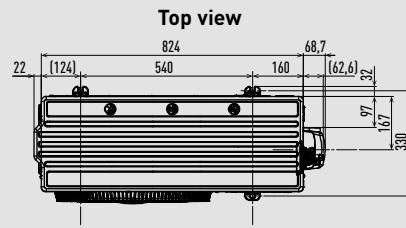

Side view

Front view

Side view

Side view

Front view

Side view

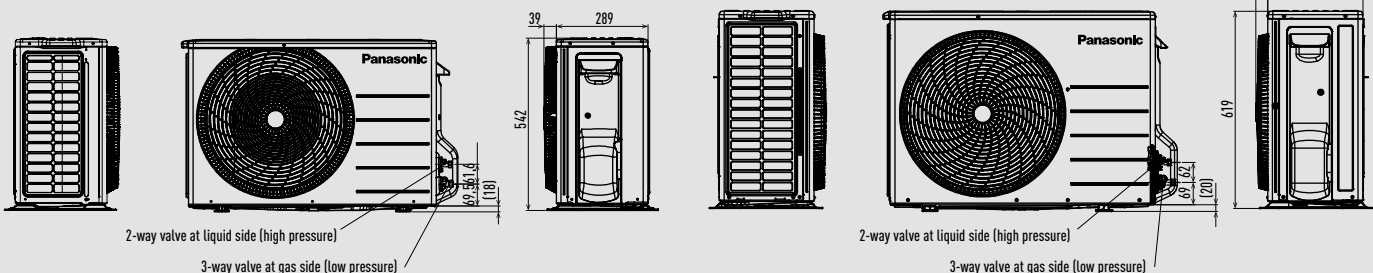

Unit: mm





Wall-mounted BZ super-compact.

Side view

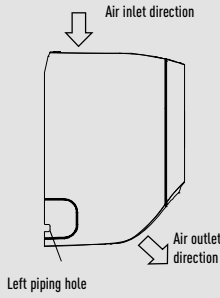

Front view



Side view

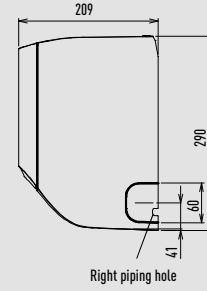

Bottom view

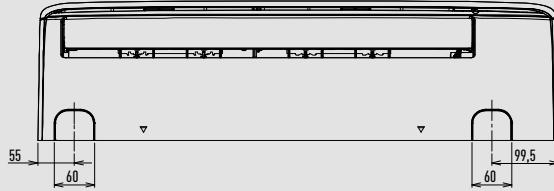

Rear view

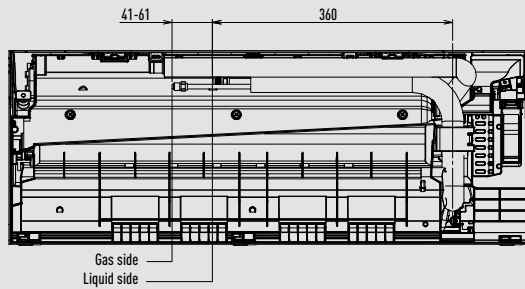

Relative position between the indoor unit and the installation plate

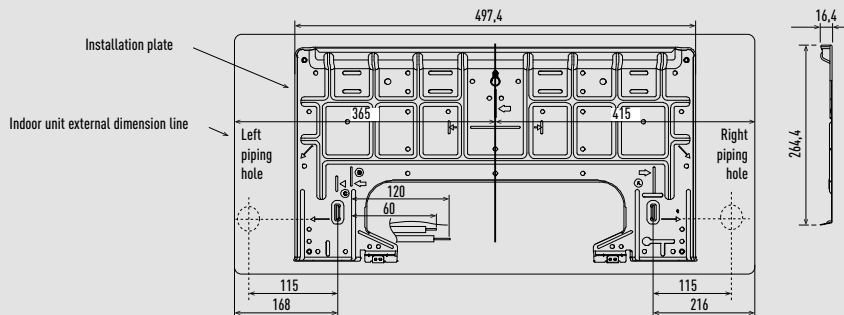

CU-BZ25ZKE / CU-BZ35ZKE

Top view

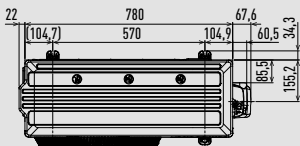

Front view

Side view

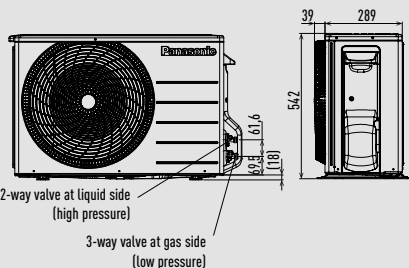

CU-BZ50ZKE

Top view

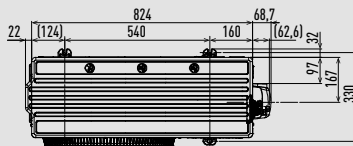

Front view

Side view

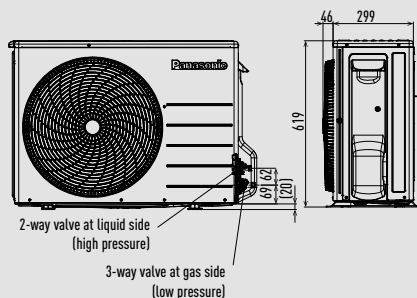

CU-BZ60ZKE

Top view

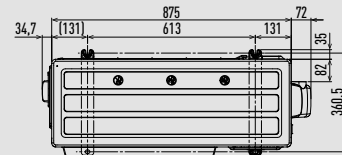

Front view

Side view

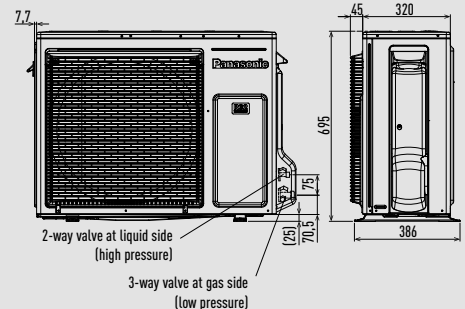

Unit: mm

Wall-mounted UZ super-compact.

Side view

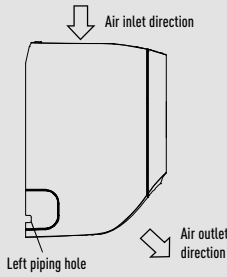

Front view



Side view

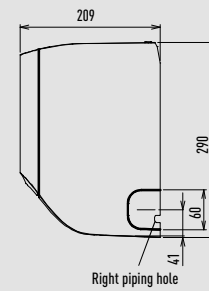

Bottom view

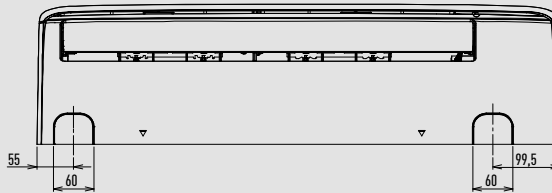

Rear view

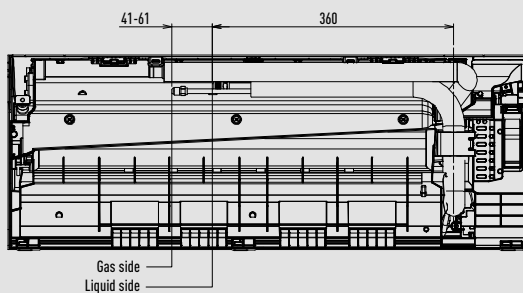

Relative position between the indoor unit and the installation plate

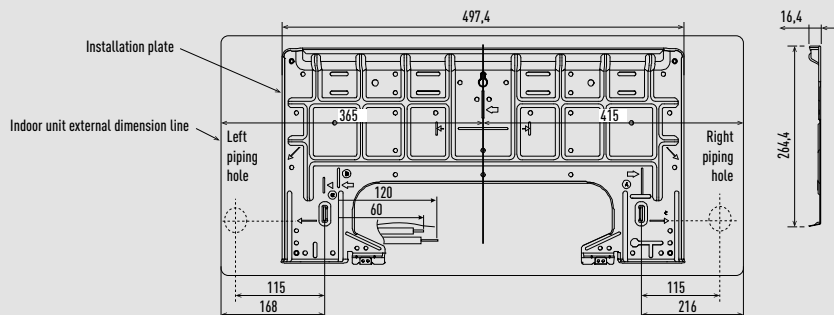

CU-UZ25ZKE / CU-UZ35ZKE

Top view

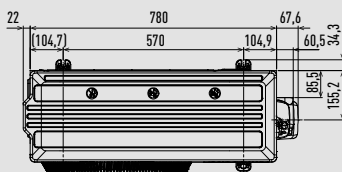

CU-UZ50ZKE

Top view

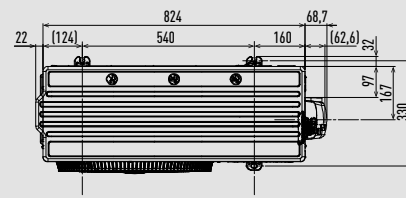

Side view

Front view

Side view

Side view

Front view

Side view

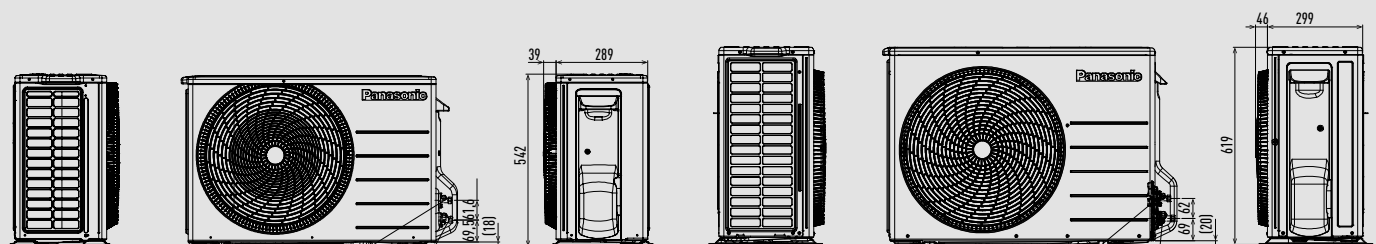

2-way valve at liquid side (high pressure)  
3-way valve at gas side (low pressure)

2-way valve at liquid side (high pressure)  
3-way valve at gas side (low pressure)

Unit: mm

Floor console.

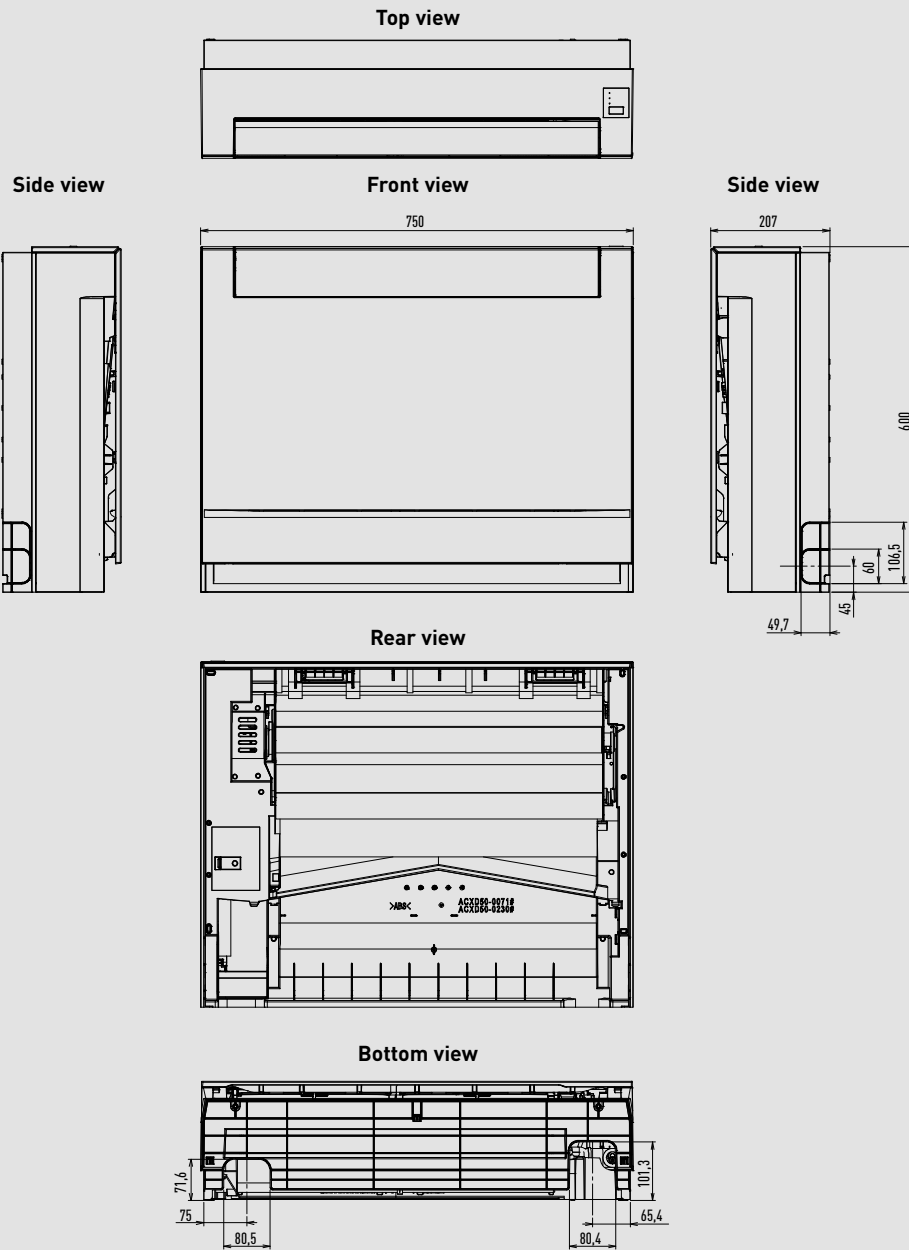

CU-Z25UBEA

CU-Z35UBEA

CU-Z50UBEA

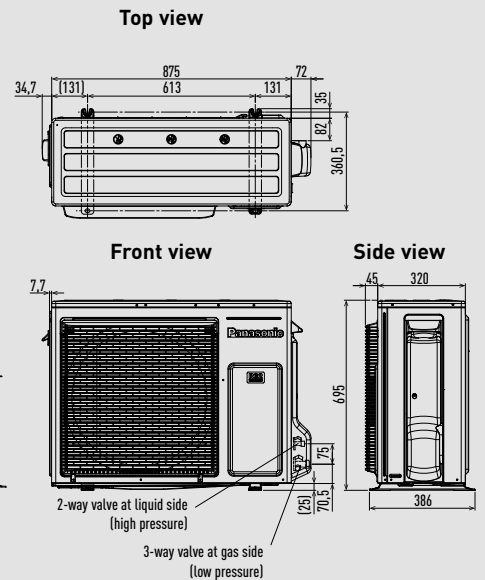
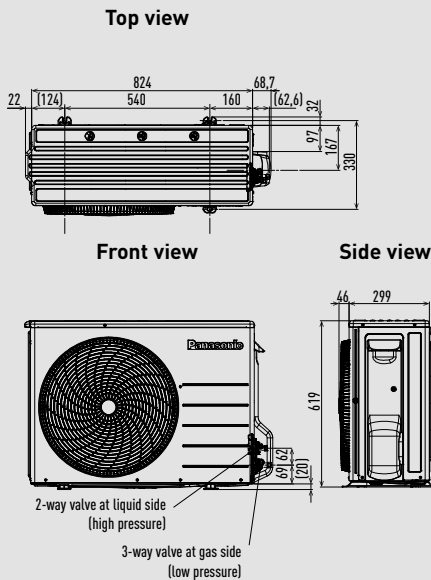
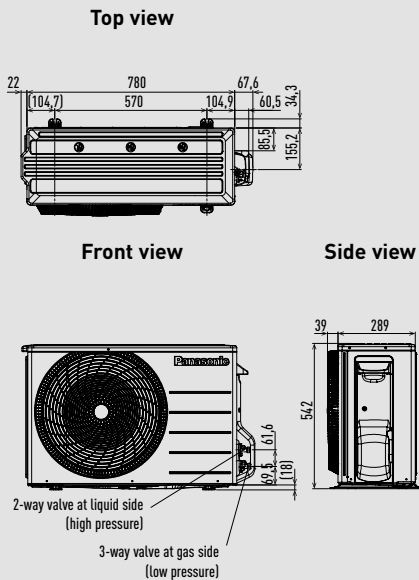

Low static pressure hide-away.

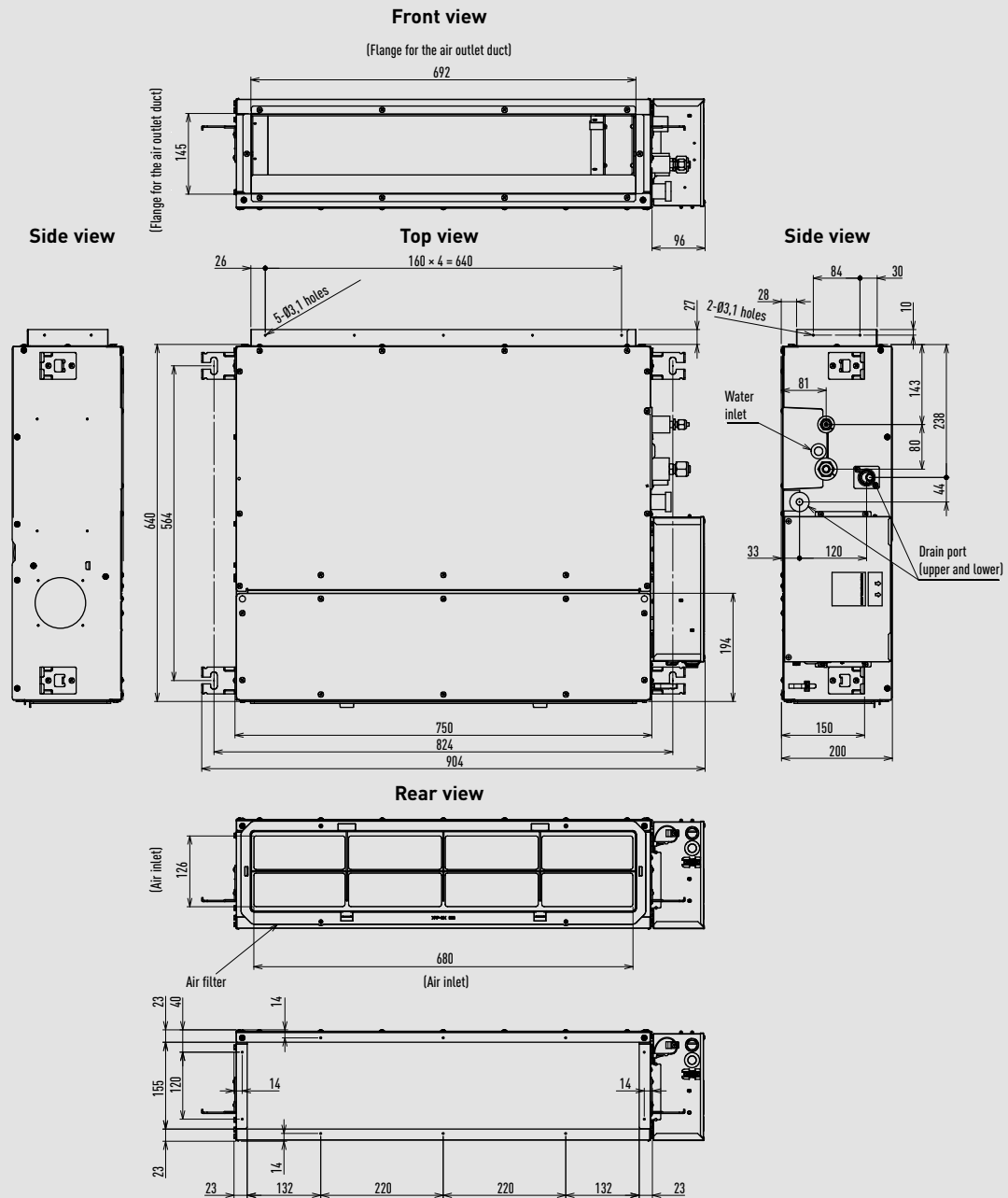

CU-Z25UBEA

Top view

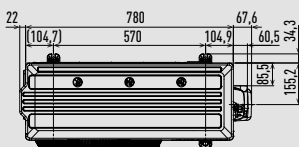

Front view

Side view

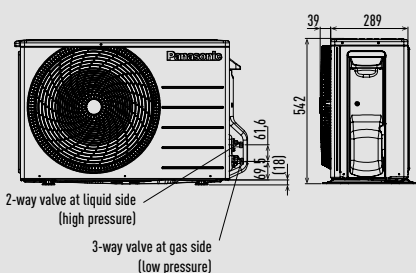

CU-Z35UBEA

Top view

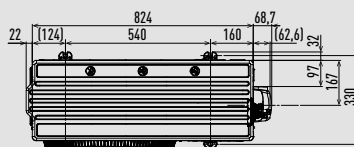

Front view

Side view

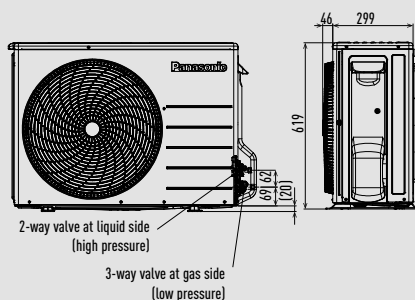

CU-Z50UBEA / CU-Z60UBEA

Top view

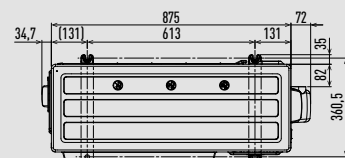

Front view

Side view

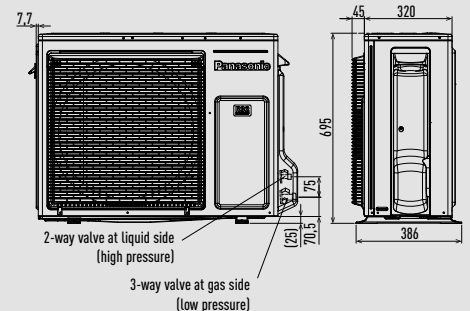

Unit: mm

Indoor unit Free Multi system Z - 4 Way 60x60 cassette.

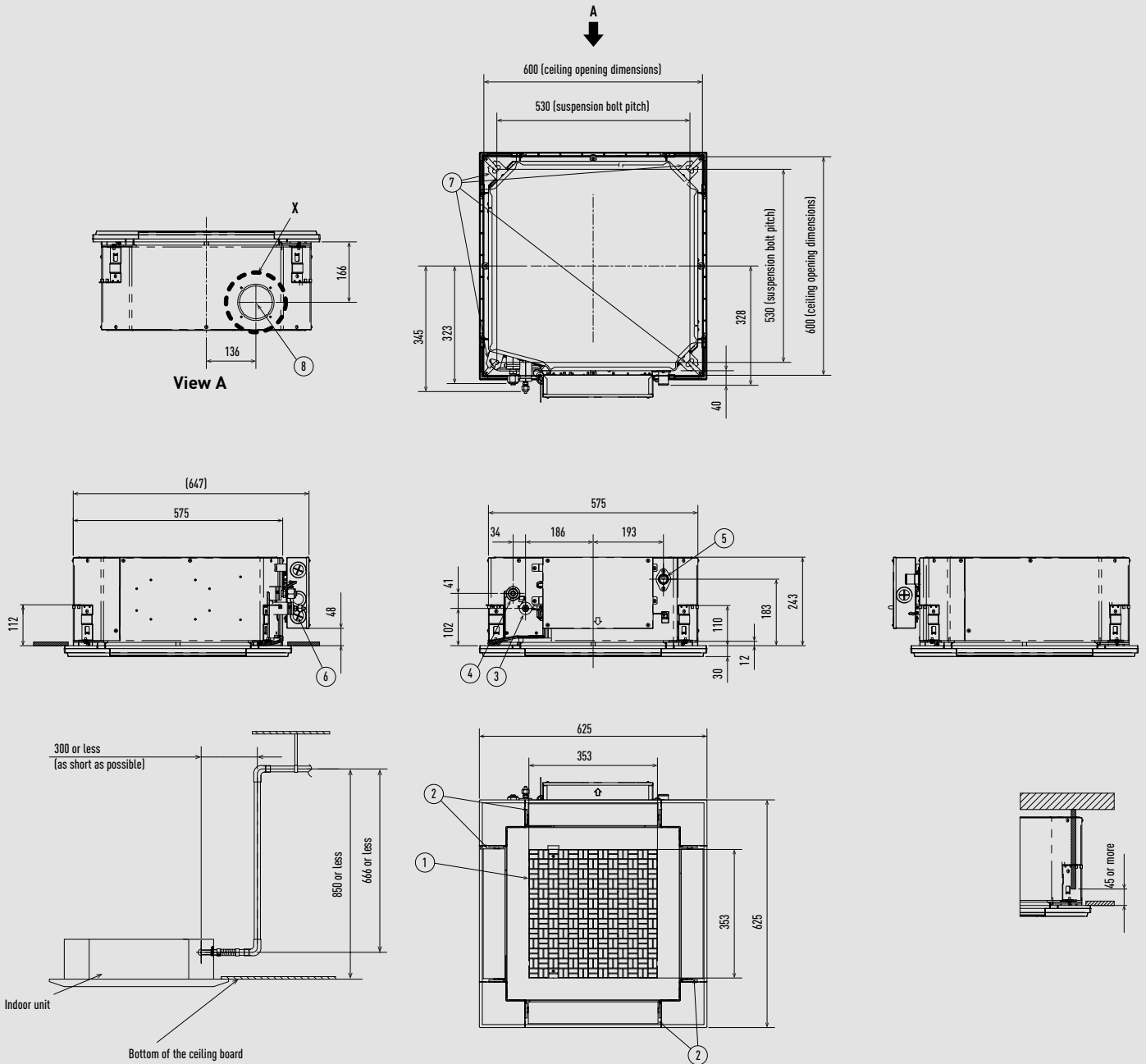

\* Length of supplied drain piping= 250 mm.

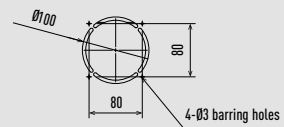

Type	20-50	60
1 Air inlet		
2 Air outlet		
3 Refrigerant piping (liquid)	$\text{Ø}6,35$ (flared)	$\text{Ø}9,52$ (flared)
4 Refrigerant piping (gas)	$\text{Ø}12,70$ (flared)	$\text{Ø}15,88$ (flared)
5 Drain piping connection port VP20		
6 Power supply port		
7 Suspension bolt hole (4-11x26 slot)		
8 Fresh air inlet duct connection port ( $\text{Ø}100$ ) <sup>1)</sup>		

1) Necessary to attach duct connecting flange (field supply).

Filter dimension: 362 x 362 x 15 mm.

Outdoor units Free Multi System Z.

CU-2Z35TBE / CU-2Z41TBE / CU-2Z50TBE

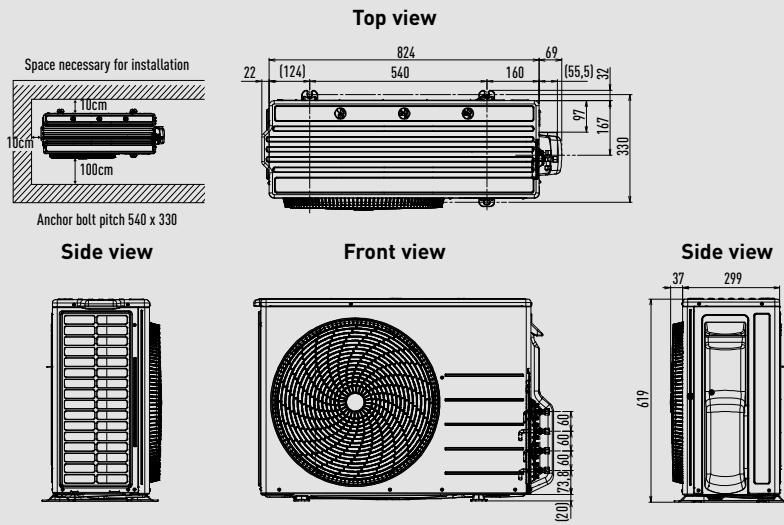

CU-3Z52TBE / CU-3Z68TBE / CU-4Z68TBE

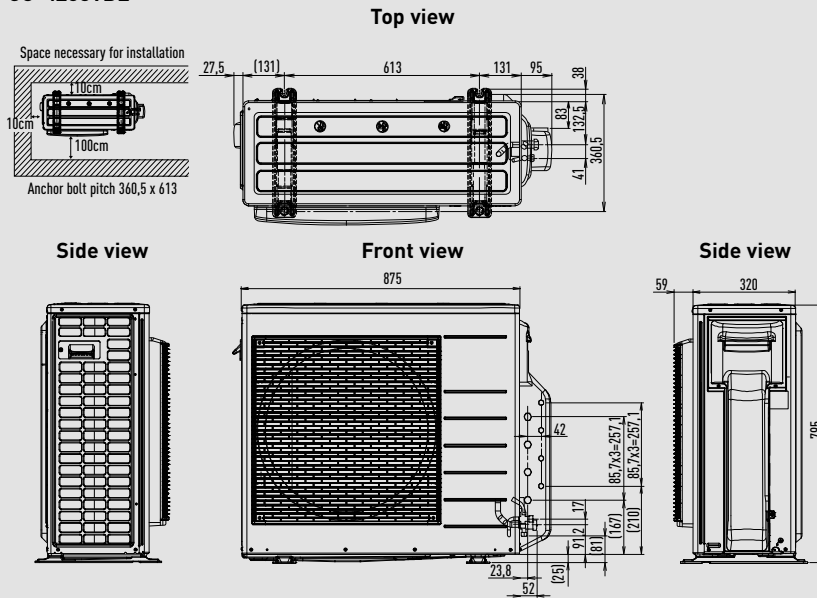

CU-4Z80TBE / CU-5Z90TBE

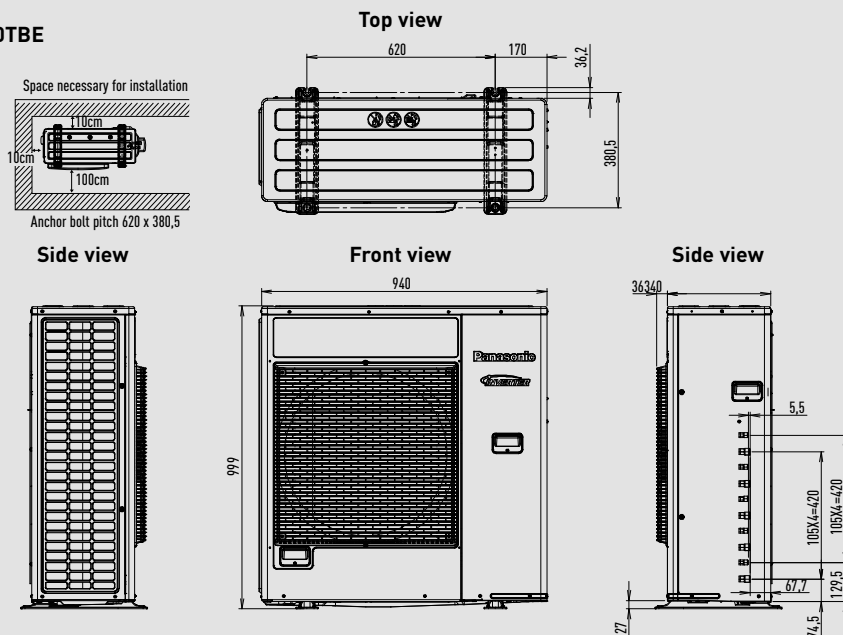

Unit: mm

Outdoor units Multi Wall TZ.

CU-2TZ41TBE / CU-2TZ50TBE

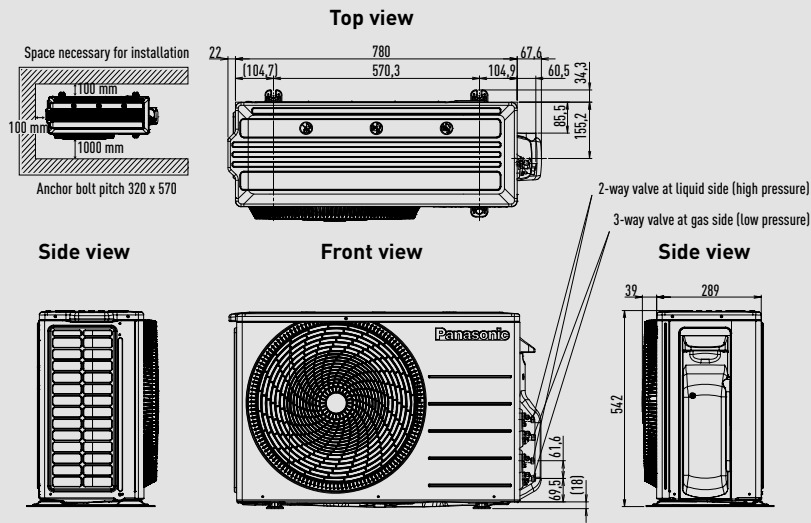

CU-3TZ52TBE

