

SAMSUNG

SINGLE

Technical

Data Book

SINGLE for Europe
(R32, Heat Pump)



Model : AC***RN**KG/EU (Indoor Unit), AC***RXADKG/EU (Outdoor Unit)

History

Version	Modification	Date	Remark
Ver.1.0	Released Single for Europe (R32, HP) TDB	'18. 12. 20	

Features & Benefits

CAC - World-class energy efficiency

Maintain optimal comfort and control with energy and cost-efficient technologies

Featuring a suite of energy-optimizing technologies, Samsung CAC Single delivers top-class energy efficiency to support business in saving costs and the environment. Plus, CAC Single with its smart technologies fully complies with new European Union (EU) regulations for more efficient performance.

Small package, big performance

The Samsung Ceiling Type air conditioner boasts a slim, compact design—half the size of conventional products—with cooling power comparable to larger units.

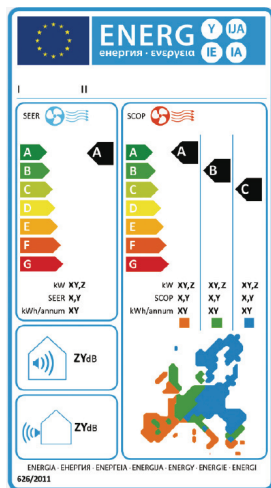

New Energy Label

*Table 1: Introduction of revised energy consumption labelling for air conditioners as per EU Directive 2011/626/EU

Quick, efficient heating and cooling

Smart inverter technology offers powerful, quick cooling and heating with minimal electricity consumption, which means real cost savings and less energy waste. The EU has established new regulations to drastically cut the power consumption of air conditioners. Inefficient units will be gradually withdrawn from the market starting in 2013. To further support this initiative, the EU is introducing an improved energy labeling system to provide consumers a better idea of how much electricity their units consume.

Up to 50 percent less energy use

After reaching changes its operation mode to economical. By avoiding inefficient and frequent switching on and off of the compressor, the digital inverter saves up to 50 percent in energy consumption compared to non-inverter air conditioners.

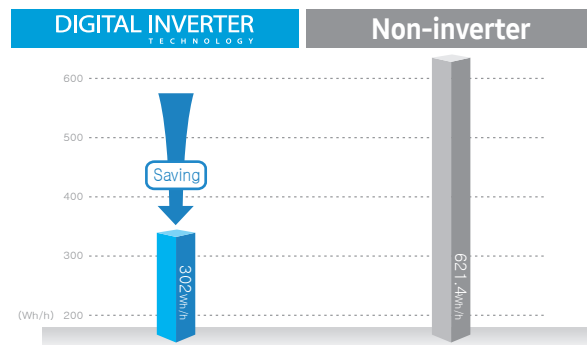

Multi-unit operation

Instead of connecting just one indoor unit, users can connect two, three or four indoor units with a single outdoor unit for more efficient cooling and heating. The indoor units operate and are controlled simultaneously as one cycle within the same mode via one remote controller for up to four rooms. This system is ideal for spaces requiring multiple indoor units, such as open-plan offices or shops.

Outdoor Unit Capacity	2 Rooms	3 Rooms	4 Rooms
7.1kW	3.5 + 3.5		
10kW	5.2 + 5.2		
12kW		5.2 + 5.2 + 5.2	
14kW	7.1 + 7.1	5.2 + 5.2 + 5.2	3.5 + 3.5 + 3.5 + 3.5

All types of indoor units are available except console. (the same models only)

Features & Benefits

CAC Single - Superior performance

Stabilize the atmosphere with broad temperature allowance and control

Samsung is dedicated to supporting comfortable living and working environments based on the strength of its technologies. With a single unit, CAC Single delivers reliable comfort and control over multiple areas to ensure a pleasant atmosphere in any climate.

Wide temperature performance

No matter how extreme the temperature, the high-performing CAC Single can handle the condition—without the need for an additional unit. Featuring a wide temperature allowance, it can cool in heat of up to 50 and provide warmth in the freezing cold of -20°C to ensure a constant and comfortable home environment.

Ideal comfort in minutes

The CAC Single digital inverter air conditioner works at maximum capacity at startup. As soon as the temperature reaches the desired or set temperature, CAC Single performs fine adjustments to cope with any changes. This means less temperature fluctuation and ideal comfort in a matter of minutes.

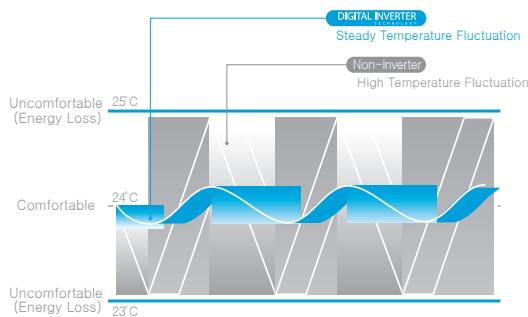

Versatile piping installation

CAC Single outdoor units offer a selection of pipe directions. The internal pipe connection ports allow four different pipe directions, supporting a neater, more organized-looking unit upon installation.



Low CO₂ Emission

Introducing R32 CAC makes it possible to reduce 70% of CO₂ Emission.

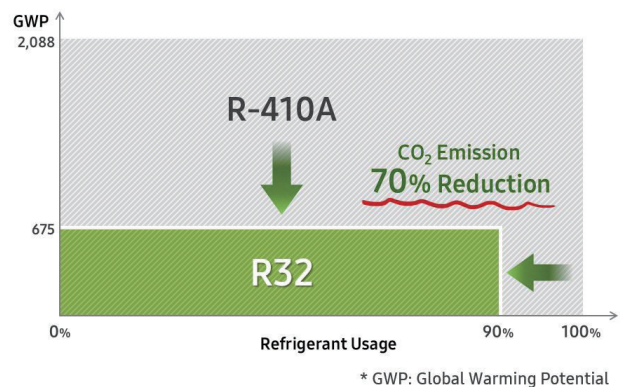

Nomenclature

Indoor Unit

Model Name

AC	052	R	N	4	D	K	G	/	EU
(1)	(2)	(3)	(4)	(5)	(6)	(7)	(8)		Buyer

(1) Classification

AC	CAC
-----------	-----

(2) Capacity

x1/10 kW (3 digits)

(3) Version

N	2018
R	2019

(4) Product Type

N	Indoor Unit
X	Outdoor Unit

(5) Product Notation

1	1 Way Cassette Wind-Free 1Way Cassette
N	4 Way Cassette (600x600) Wind-Free 4 Way Cassette (600x600)
4	4 Way Cassette, 360 Cassette Wind-Free 4 Way Cassette
L	LSP Duct
M	MSP Duct
C	Ceiling
J	Console
A	A3050 (Wall Mounted)

(6) Feature

F	Flagship
S	Standard
D	Deluxe
P	Premium

(7) Rating Voltage

K	1Φ, 220~240V, 50Hz
----------	--------------------

(8) Mode

G	Heat Pump (R32)
----------	-----------------

Nomenclature

Outdoor Unit

Model Name

AC	052	R	X	A	D	K	G	/	EU
(1)	(2)	(3)	(4)	(5)	(6)	(7)	(8)		Buyer

(1) Classification

AC	CAC
----	-----

(5) Product Notation

A,1	Inv+Side+General Temp
-----	-----------------------

(2) Capacity

X1/10 kW (3 digits)

(6) Feature

F	Flagship
S	Standard
D	Deluxe
P	Premium

(3) Version

N	2018
R	2019

(7) Rating Voltage

K	1Φ, 220~240V, 50Hz
N	3Φ, 380~415V, 50Hz

(4) Product Type























N	Indoor Unit
X	Outdoor Unit

(8) Mode



G	Heat Pump (R32)
---	-----------------

Line-up

Indoor unit

Model	Capacity (kW)			
	2.6	3.5	5.2	7.1
Wind-Free 1Way Cassette				
Wind-Free 4Way Cassette (600 x 600)				
Wind-Free 4Way Cassett				
360 Cassette				
LSP Duct				
MSP Duct				
Wall-mounted				
Ceiling				

Outdoor Unit

Model	Capacity (kW)			
	2.6	3.5	5.2	7.1
1Phase				

Contents

Wind-Free 1Way Cassette	9
Wind-Free 4Way Cassette (600x600)	22
Wind-Free 4Way Cassette	42
360 Cassette	56
LSP Duct	72
MSP Duct	95
Wall Mounted Type (A3050)	113
Ceiling	135
Outdoor Units	150
Installation	177

Wind-Free 1Way Cassette

1. Specification	11
2. Summary Table	14
3. Capacity Table	15
4. Dimensional Drawing	16
5. Center of Gravity	17
6. Electrical Wiring Diagram	18
7. Sound Data	19
8. Temperature and airflow distribution	21

Features & Benefits

Wind-Free 1Way Cassette

1. Wind-Free cooling

Comfort wind implementation by Wind-Free cooling

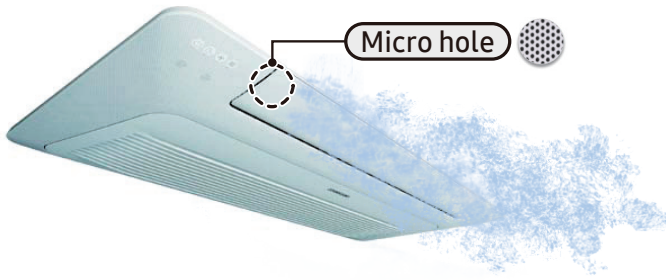

※ Wind-Free implementation : Still air by the velocity of flow below 0.15m/s.

2. Big blade

Max. 5.5m Horizontal reach

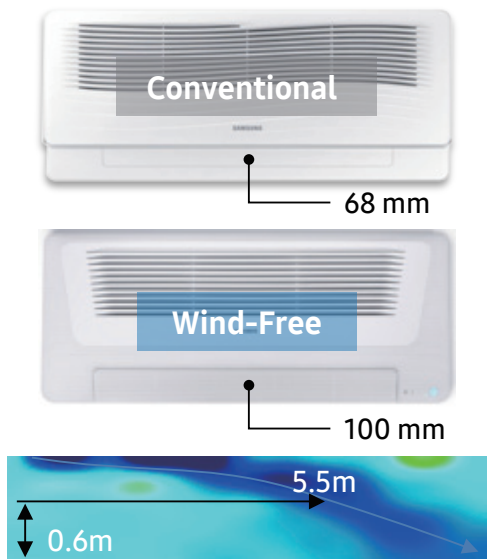

※ Reach : 5.5m (Height 0.6m, Wind speed 0.3m/s)
Conventional product (Samsung) : 3m

※ Based on Wind-Free 1Way 3.5kW

3. Even cooling

Even cooling For spacious space

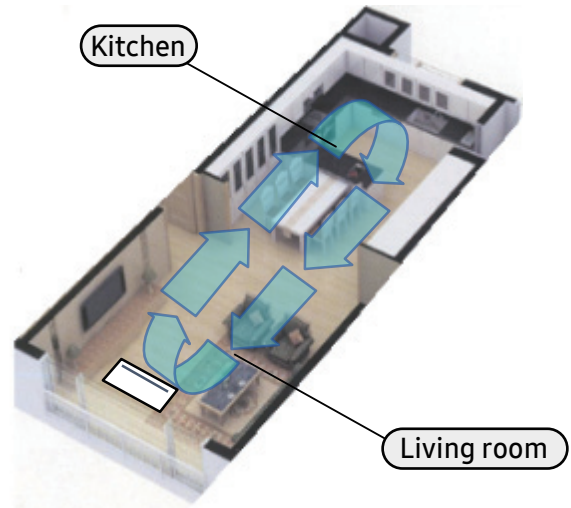

※ Expand the blade angle from 30° to 80°
Conventional product (Samsung) : 40~80 °

1. Specification

Wind-Free 1Way Cassette

Model Name	Indoor Unit			AC026RN1DKG/EU	AC035RN1DKG/EU	
	Outdoor Unit			AC026RXADKG/EU	AC035RXADKG/EU	
Mode				-	HEAT PUMP	
Performance	Capacity (Min/Std/Max)	Cooling	kW	0.82 / 2.60 / 3.80	0.85 / 3.50 / 4.20	
			Btu/h	2,800 / 8,870 / 12,970	2,900 / 11,940 / 14,330	
		Heating	kW	0.98 / 3.30 / 4.40	1.00 / 4.00 / 5.00	
			Btu/h	3,340 / 11,260 / 15,000	3,410 / 13,650 / 17,060	
Power	Power Input (Min/Std/Max)	Cooling	kW	0.17 / 0.72 / 1.16	0.18 / 1.09 / 1.40	
		Heating	kW	0.20 / 1.01 / 1.45	0.19 / 1.28 / 1.80	
	Current Input (Min/Std/Max)	Cooling	A	1.2 / 3.8 / 5.4	1.6 / 5.3 / 7.5	
		Heating	A	1.4 / 5.0 / 7.0	1.3 / 6.2 / 10.5	
	Current	MCA	A	11.0	11.0	
		MFA	A	12.5	12.5	
Efficiency	EER	Cooling	-	3.61	3.21	
	COP	Heating	-	3.26	3.12	
	SEER (Cooling Energy Grade)		-	6.4 (A++)	6.2 (A++)	
	SCOP (Heating Energy Grade)		-	4.0 (A+)	4.0 (A+)	
	Pdesignh		kW	2.0	2.0	
Piping Connections	Liquid Pipe	Type		Flare connection	Flare connection	
		Φ, mm (inch)		6.35 (1/4)	6.35 (1/4)	
	Gas Pipe	Type		Flare connection	Flare connection	
		Φ, mm (inch)		9.52 (3/8)	9.52 (3/8)	
	Heat Insulation		-	Both liquid and gas pipes	Both liquid and gas pipes	
	Piping length (ODU-IDU)	Standard	m		5	5
			Max.		20	20
Elevation				15	15	
Chargeless				20	20	
Wiring connections	Communication	Min.	mm ²	0.75	0.75	
		Remark	-	F1, F2	F1, F2	
Refrigerant	Type		-	R32	R32	
	Factory Charging	kg		0.9	0.9	
		tCO ₂ e		0.61	0.61	

1. Specification

Wind-Free 1Way Cassette

Model Name	Indoor Unit		AC026RN1DKG/EU	AC035RN1DKG/EU	
	Outdoor Unit		AC026RXADKG/EU	AC035RXADKG/EU	
Power Supply		Ø, #, V, Hz	1,2,220-240,50	1,2,220-240,50	
Heat Exchanger	Type		-	F&T	
	Material	Fin	-	Al	
		Tube	-	Cu	
	Fin Treatment		-	Green Hydrophile	
Fan	Type		-	Crossflow Fan	
	Quantity		EA	1	
	Air Flow Rate	Cooling (H/M/L)	m ³ /min	7.3 / 6.5 / 5.8	9.0 / 8.2 / 7.2
			l/s	121.6 / 108.3 / 96.6	150 / 136.6 / 120
		Heating (H/M/L)	m ³ /min	8.5 / 7.2 / 6.5	10.0 / 8.4 / 7.3
			l/s	141.6 / 120 / 108.3	166.6 / 140 / 121.6
Fan Motor	Type		-	BLDC	
	Output		W x n	27	
Drain	Drain Pipe		Ø, mm	VP-20(OD26, ID20)	
Sound	Sound Pressure Level	High/Mid/Low/(Silent)	dB(A)	32 / 29 / 26 / 25	
	Sound Power Level		dB(A)	54	
External Dimension	Net Weight		kg	9.2	
	Shipping Weight		kg	12.0	
	Net Dimensions (WxHxD)		mm	970 x 135 x 410	
	Shipping Dimensions (WxHxD)		mm	1,173 x 231 x 487	
Casing	Material		-	ABS	
Indoor Unit Panel (1)	Model Name		-	PC1NWFMAN	
	Type		-	Wind-Free Type	
	Material		-	HIPS	
	Color		-	DA White	
	Net Weight		kg	4.3	
	Shipping Weight		kg	6.3	
	Net Dimensions (WxHxD)		mm	1,198 x 35 x 500	
	Shipping Dimensions (WxHxD)		mm	1,262 x 122 x 566	
Panel (2)	Model Name		-	PC1NWSMAN	
	Type		-	Fluid Type	
	Material		-	ABS	
	Color		-	White	
	Net Weight		kg	5.5	
	Shipping Weight		kg	7.2	
	Net Dimensions (WxHxD)		mm	1,198 x 25 x 500	
	Shipping Dimensions (WxHxD)		mm	1,275 x 152 x 580	
Control System	Infrared remote control		-	AR-EH03E	
	Wired remote control		-	MWR-WE13N MWR-WG00*N	
Drain Pump	Drain Pump		-	Included	
	Max. lifting Height / Displacement		mm / Liter / h	750/24	
Additional Accessories	Drain Pump	External Model	-	-	
		Internal Model	-	-	
	Max. lifting Height / Displacement		mm / Liter / h	-	-
	Air Filter		-	Removable / Washable	Removable / Washable
Virus Doctor		-	-	-	

1. Specification

Wind-Free 1Way Cassette

Model Name	Indoor Unit			AC026RN1DKG/EU	AC035RN1DKG/EU
	Outdoor Unit			AC026RXADKG/EU	AC035RXADKG/EU
Power Supply			Ø, #, V, Hz	1, 2, 220-240, 50	1, 2, 220-240, 50
Heat Exchanger	Type		-	Fin & Tube	Fin & Tube
	Material	Fin	-	Al	Al
		Tube	-	Cu	Cu
Fin Treatment		-	Anti-Corrosion	Anti-Corrosion	
Compressor	Model Name			UB9AK5090FER	UB9AK5090FER
	Type		-	Single BLDC	Single BLDC
	Output		kW	0.86	0.86
	Oil	Type	-	POE	POE
Initial charge		cc	320	320	
Fan	Type		-	Propeller	Propeller
	Discharge direction		-	Front	Front
	Quantity		EA	1	1
	Air Flow Rate		m ³ /min	30	30
l/s			500	500	
Fan Motor	Type		-	BLDC Motor	BLDC Motor
	Output		W x n	40 x 1	40 x 1
Sound	Sound Pressure Level	Cooling	dB(A)	46	48
		Heating	dB(A)	47	48
	Sound Power Level		dB(A)	59	61
External Dimension	Net Weight		kg	32.5	32.5
	Shipping Weight		kg	35.5	35.5
	Net Dimensions (WxHxD)		mm	790 x 548 x 285	790 x 548 x 285
	Shipping Dimensions (WxHxD)		mm	913 x 622 x 371	913 x 622 x 371
Casing	Material	Body	-	EGI Steel Plate	EGI Steel Plate
	Operating Temp. Range		°C	-15 ~ 46	-15 ~ 46
			°C	-20 ~ 24	-20 ~ 24

NOTE

- Specification may be subject to change without prior notice.
- 1) Performances are based on the following test conditions.
 - Cooling : Indoor temperature 27°C DB, 19°C WB, Outdoor temperature 35°C DB, 24°C WB
 - Heating : Indoor temperature 20°C DB, 15°C WB, Outdoor temperature 7°C DB, 6°C WB
 - Equivalent refrigerant pipe length 5m, Level differences 0m
- 2) Select wire size based on the value of MCA
- 3) Sound pressure level is obtained in an anechoic room.
 - Sound pressure level is a relative value, depending on the distance and acoustic environment.
 - Sound pressure level may differ depending on operation condition.
 - dBA = A-weighted sound pressure level
 - Reference acoustic pressure 0 dB = 20uPa
- 4) Sound power level is an absolute value that a sound source generates.
 - dBA = A-weighted sound power level
 - Reference power : 1pW
 - Measured according to ISO 3741
- 5) These products contain R32(GWP=675) which is fluorinated greenhouse gas.
- 6) 'MWR-WG00*N' is new wired remote control type(Graphic).
If you need the latest control system information, please refer to SAC control TDB.

2. Summary Table

Wind-Free 1Way Cassette

Performance Characteristics

Model Code	Net Weight (kg)	Capacity			Fan Speed	Airflow (CMM)	Sound Pressure Level (dBA)	Sound Power Level (dBA)
			Cooling (kW)	Heating (kW)				
AC026RN1DKG/EU	9.5	Max.	3.80	4.40	High	7.3	32	54
		Std.	2.60	3.30	Mid	6.5	29	
		Min.	0.82	0.98	Low	5.8	26	
AC035RN1DKG/EU	9.5	Max.	4.20	5.00	High	9.0	35	57
		Std.	3.50	4.00	Mid	8.2	32	
		Min.	0.85	1.00	Low	7.2	29	

NOTE

- Sound data is based on cooling operation.

Electric Characteristics

Model		Outdoor Unit				Maximum Input Current [A]				Power Supply	
Indoor Unit	Outdoor Unit	Rated	Voltage range			Outdoor Unit		Indoor Unit	Total	MCA	MFA
			Hz	Volts	Min.	Max.	Cooling				
AC026RN1DKG/EU	AC026RXADKG/EU	50	220 to 240	198	264	10	10	1.0	11.0	11.0	12.5
AC035RN1DKG/EU	AC035RXADKG/EU	50	220 to 240	198	264	10	10	1.0	11.0	11.0	12.5

NOTE

- MCA : Minimum circuit amperes
- MFA : Maximum fuse amperes
- Select wire size based on the value of MCA

3. Capacity Table

Wind-Free 1Way Cassette

(1) AC026RN1DKG/EU+AC026RXADKG/EU

Cooling

TC : Total Capacity, SHC : Sensible Heat Capacity, PI : Power Input

Outdoor Temperature (°C, DB)	Indoor Temperature (°C, DB / WB)																				
	20 / 14			22 / 16			25 / 18			27 / 19			28 / 20			30 / 22			32 / 24		
	TC	SHC	PI	TC	SHC	PI	TC	SHC	PI	TC	SHC	PI	TC	SHC	PI	TC	SHC	PI	TC	SHC	PI
	kW	kW	kW	kW	kW	kW	kW	kW	kW	kW	kW	kW	kW	kW	kW	kW	kW	kW	kW	kW	kW
-15	2.5	1.9	0.52	2.7	2.0	0.53	2.8	2.0	0.54	2.9	2.1	0.55	2.9	2.1	0.55	3.1	2.1	0.56	3.2	2.0	0.57
21	2.4	1.8	0.54	2.5	1.9	0.55	2.6	1.9	0.56	2.7	2.0	0.58	2.8	2.0	0.58	2.9	2.0	0.59	3.1	1.9	0.60
35	2.3	1.7	0.68	2.4	1.8	0.69	2.5	1.8	0.71	2.6	1.9	0.72	2.7	1.9	0.73	2.8	1.9	0.73	2.9	1.8	0.75
46	2.0	1.7	0.61	2.1	1.7	0.62	2.1	1.8	0.64	2.2	1.9	0.65	2.3	1.8	0.65	2.4	1.8	0.66	2.5	1.8	0.67

Heating

TC : Total Capacity, PI : Power Input

Outdoor Temperature (°C, DB)	Indoor Temperature (°C, DB)													
	16		18		20		21		22		24			
	TC	PI	TC	PI	TC	PI	TC	PI	TC	PI	TC	PI		
	kW	kW	kW	kW	kW	kW	kW	kW	kW	kW	kW	kW		
-20	2.3	1.34	2.3	1.33	2.3	1.31	2.3	1.30	2.2	1.29	2.2	1.27		
-15	2.9	1.55	2.9	1.53	2.9	1.52	2.8	1.50	2.8	1.48	2.8	1.47		
-5	3.3	1.44	3.3	1.43	3.2	1.41	3.2	1.40	3.2	1.39	3.1	1.37		
0	3.4	1.24	3.4	1.22	3.4	1.21	3.3	1.20	3.3	1.19	3.3	1.18		
7	3.4	1.03	3.3	1.02	3.3	1.01	3.3	1.00	3.2	0.99	3.2	0.98		
24	4.4	1.18	4.3	1.17	4.3	1.16	4.2	1.15	4.2	1.14	4.2	1.13		

(2) AC035RN1DKG/EU+AC035RXADKG/EU

Cooling

TC : Total Capacity, SHC : Sensible Heat Capacity, PI : Power Input

Outdoor Temperature (°C, DB)	Indoor Temperature (°C, DB / WB)																				
	20 / 14			22 / 16			25 / 18			27 / 19			28 / 20			30 / 22			32 / 24		
	TC	SHC	PI	TC	SHC	PI	TC	SHC	PI	TC	SHC	PI	TC	SHC	PI	TC	SHC	PI	TC	SHC	PI
	kW	kW	kW	kW	kW	kW	kW	kW	kW	kW	kW	kW	kW	kW	kW	kW	kW	kW	kW	kW	kW
-15	3.4	2.5	0.78	3.6	2.6	0.80	3.7	2.7	0.81	3.9	2.8	0.83	3.9	2.7	0.84	4.1	2.7	0.84	4.3	2.6	0.86
21	3.3	2.4	0.82	3.4	2.5	0.84	3.6	2.5	0.85	3.7	2.6	0.87	3.7	2.6	0.88	3.9	2.6	0.89	4.1	2.5	0.91
35	3.1	2.3	1.03	3.3	2.4	1.05	3.4	2.4	1.07	3.5	2.5	1.09	3.6	2.5	1.10	3.7	2.5	1.11	3.9	2.4	1.13
46	2.6	2.1	0.92	2.8	2.2	0.94	2.9	2.3	0.96	3.0	2.3	0.98	3.0	2.3	0.99	3.2	2.3	1.00	3.3	2.3	1.02

Heating

TC : Total Capacity, PI : Power Input

Outdoor Temperature (°C, DB)	Indoor Temperature (°C, DB)													
	16		18		20		21		22		24			
	TC	PI	TC	PI	TC	PI	TC	PI	TC	PI	TC	PI		
	kW	kW	kW	kW	kW	kW	kW	kW	kW	kW	kW	kW		
-20	2.8	1.70	2.8	1.68	2.8	1.66	2.7	1.65	2.7	1.63	2.7	1.61		
-15	3.5	1.96	3.5	1.94	3.5	1.92	3.4	1.90	3.4	1.88	3.4	1.86		
-5	4.0	1.83	4.0	1.81	3.9	1.79	3.9	1.77	3.8	1.76	3.8	1.74		
0	4.2	1.57	4.1	1.55	4.1	1.54	4.0	1.52	4.0	1.51	4.0	1.49		
7	4.1	1.31	4.0	1.29	4.0	1.28	4.0	1.27	3.9	1.25	3.9	1.24		
24	5.3	1.50	5.3	1.49	5.2	1.47	5.1	1.46	5.1	1.44	5.0	1.43		

NOTE

- The performance table shows the average value of each conditions.

4. Dimensional Drawing

Wind-Free 1Way Cassette

AC026/035RN1DKG/EU

Units : mm [inches]

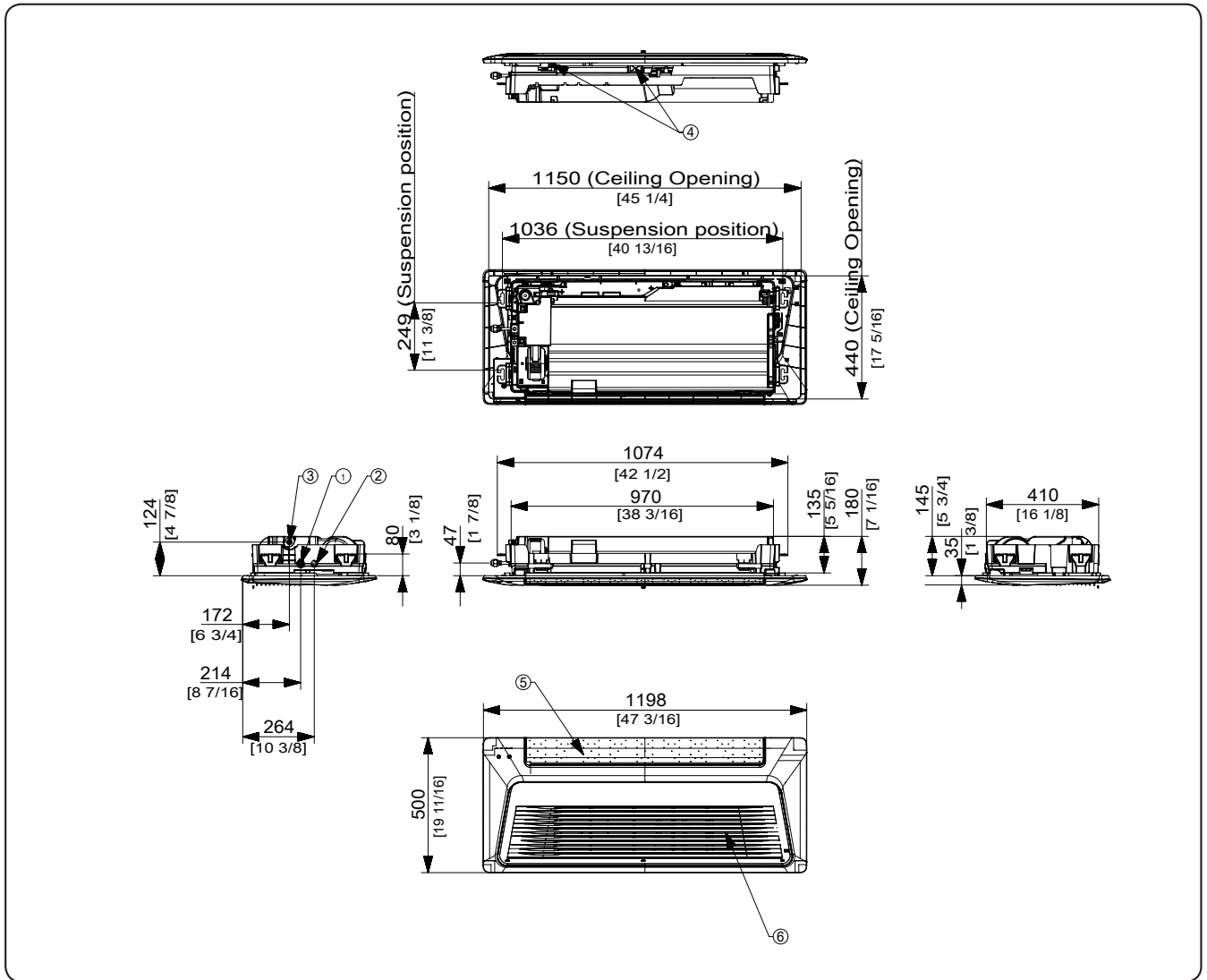

No.	Name	Description
1	Gas pipe connection	Φ 9.52 (3/8)
2	Liquid pipe connection	Φ 6.35 (1/4)
3	Drain pipe connection	VP-20 (OD26, ID20)
4	Power supply & Communication wiring conduit	-
5	Air outlet louver	-
6	Air inlet grille	-

NOTE

- As for suspension bolt, please use M8 ~ M10.
(Procured at local site)

5. Center of Gravity

Wind-Free 1Way Cassette

Units : mm [inches]

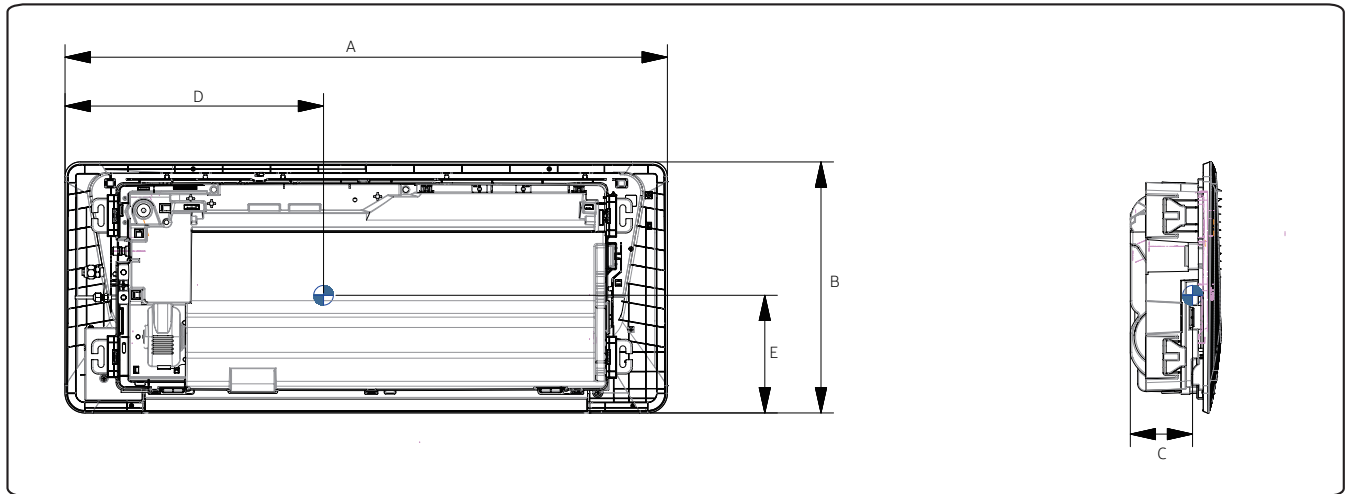

Model	A	B	C	D	E
AC026/035RN1DKG/EU	1,198 [47-3/16]	500 [19-11/16]	108 [4-1/2]	555 [21-7/8]	200 [7-7/8]

6. Electrical Wiring Diagram

Wind-Free 1Way Cassette

AC026/035RN1DKG/EU

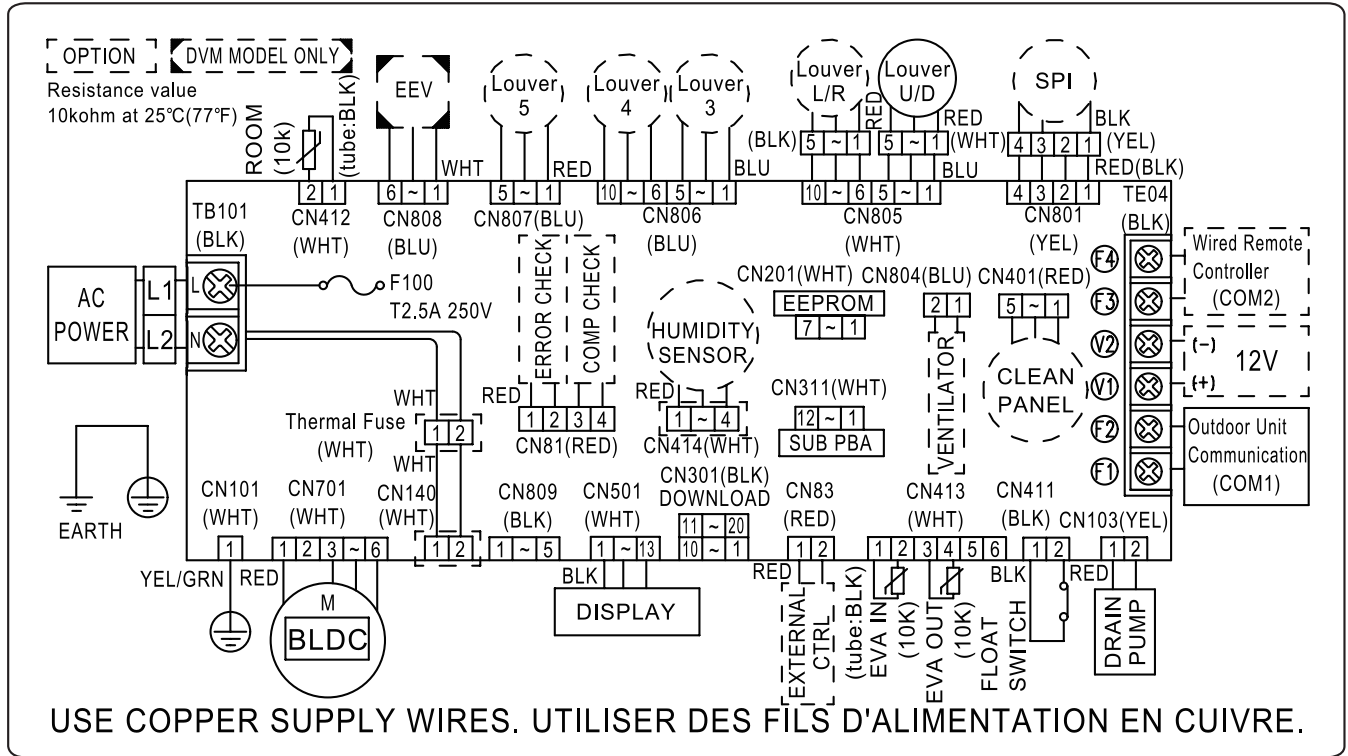

SPI	S-Plasma ion	EEV	Electronic Expansion Valve	ROOM	Thermistor ROOM in (10K)
FLOAT SWITCH	Check the FLOATING S/W	EVA-IN	Thermistor EVA IN(10K)	EVA-OUT	Thermistor EVA OUT(10K)

NOTE

- This wiring diagram applies only to the Indoor unit.
- Symbols show as follow :
blk: black, red: red, blu: blue, wht: white, yel: yellow, brn: brown, sky: skyblue: grn: green
- For connection wiring indoor-outdoor transmission F1-F2, indoor-wired remote controller transmission F3-F4.
- Protective earth(screw)

7. Sound Data

Wind-Free 1Way Cassette

Sound Pressure level

Unit: dB(A)

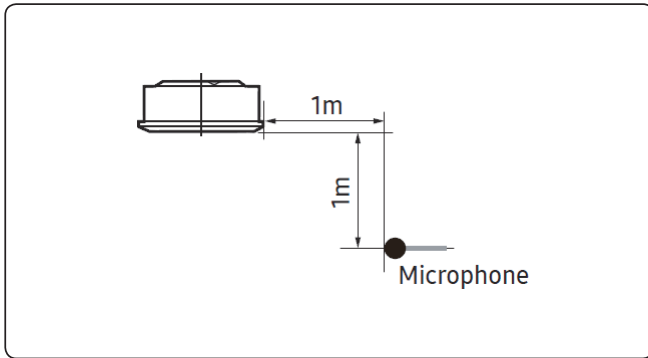

Model	HIGH	MID	LOW
AC026RN1DKG/EU	32	29	26
AC035RN1DKG/EU	35	32	29

- NC Curve

- 1) AC026RN1DKG/EU

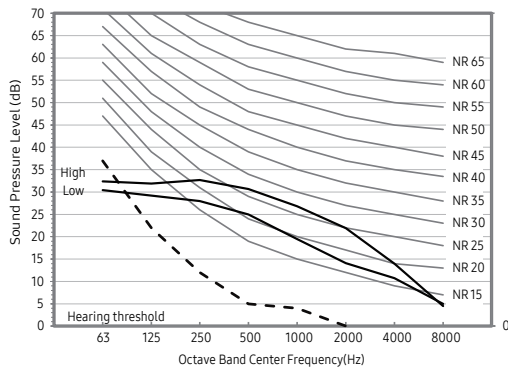

- 2) AC035RN1DKG/EU

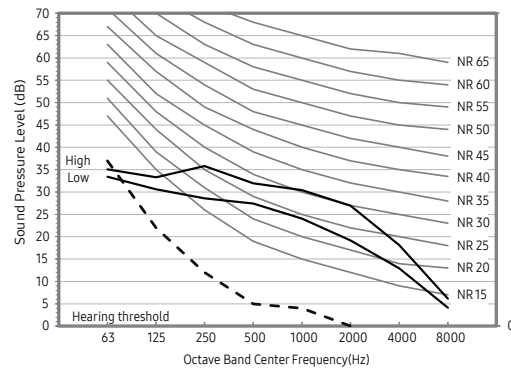

NOTE

- Specifications may be subject to change without prior notice.
 - Sound pressure level is obtained in an anechoic room.
 - Sound pressure level is a relative value, depending on the distance and acoustic environment.
 - Sound pressure level may differ depending on operation condition.
 - dBA = A weighted sound pressure level
 - Reference acoustic pressure 0 dB = 20μPa

7. Sound Data

Wind-Free 1Way Cassette

Sound Power level

NOTE

- Specifications may be subject to change without prior notice
 - Sound power level is an absolute value that a sound source generates.
 - dBA = A-weighted sound power level.
 - Reference power : 1pW.
 - Measured according to ISO 3741.

Unit: dB(A)

Model	Power
AC026RN1DKG/EU	52
AC035RN1DKG/EU	55

• NR Curve

1) AC026RN1DKG/EU

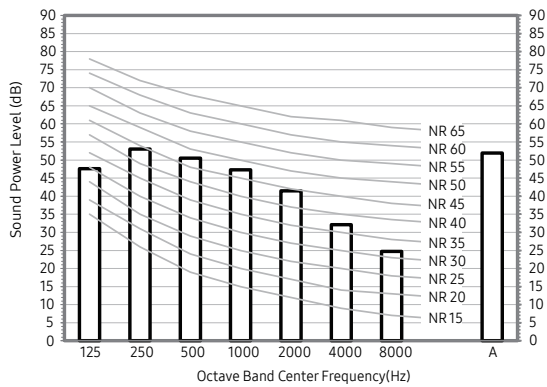

2) AC035RN1DKG/EU

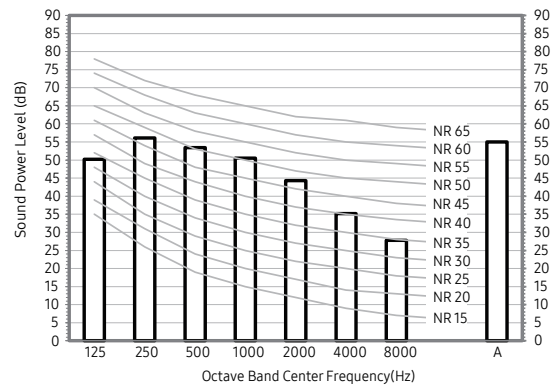

8. Temperature and airflow distribution

Wind-Free 1Way Cassette

AC026RN1DKG/EU

- Cooling Air Velocity distribution

(Discharge angle : 60 degree)

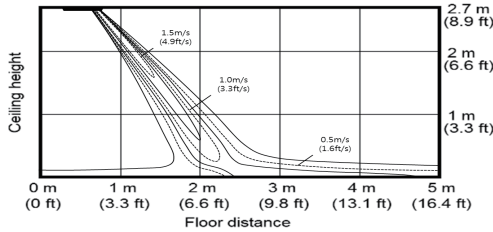

- Cooling temperature distribution

(Discharge angle : 60 degree)

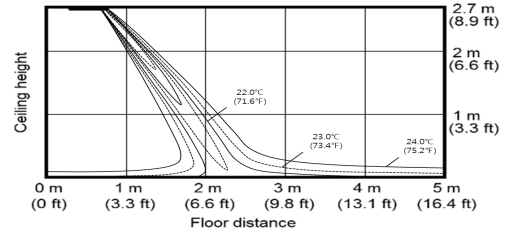

- Heating Air Velocity distribution

(Discharge angle : 60 degree)

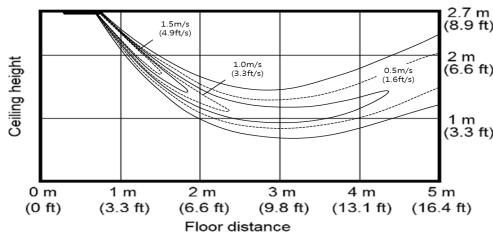

- Heating temperature distribution

(Discharge angle : 60 degree)

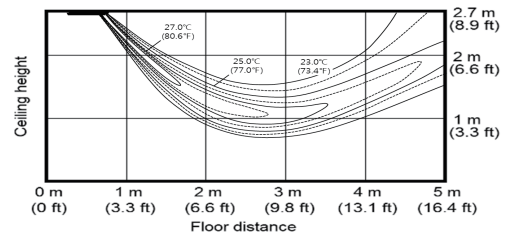

AC035RN1DKG/EU

- Cooling Air Velocity distribution

(Discharge angle : 60 degree)

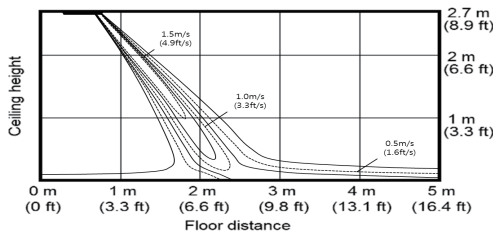

- Cooling temperature distribution

(Discharge angle : 60 degree)

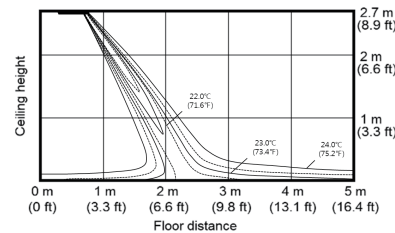

- Heating Air Velocity distribution

(Discharge angle : 60 degree)

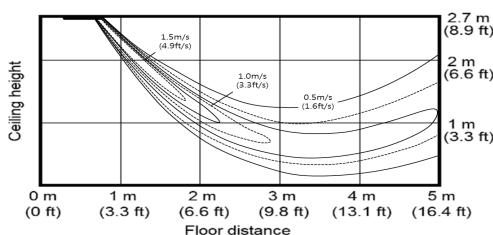

- Heating temperature distribution

(Discharge angle : 60 degree)

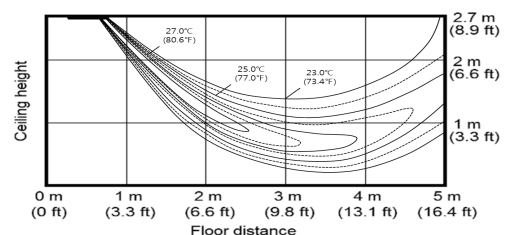

Wind-Free 4Way Cassette (600x600)

1. Specification	24
2. Summary Table	30
3. Capacity Table	31
4. Dimensional Drawing	35
5. Center of Gravity	36
6. Electrical Wiring Diagram	37
7. Sound Data	38
8. Temperature and air flow distribution	40

Features & Benefits

Add chic flair to your interior design with a stylish yet powerful AC system

Samsung's advanced Wind-Free 4Way Cassette (600 x 600) builds on the aesthetic appeal and performance of the standard Wind-Free 4Way Cassette with an enhanced design. The Wind-Free 4Way Cassette (600 x 600) comes in a variety of patterns to complement any interior. The stylish cassette unit visually harmonizes with the indoor space, while efficient cooling and heating performance make it a dependable and practical air conditioning solution.

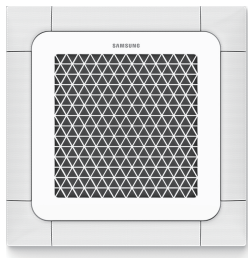

The Wind-Free 4Way Cassette (600 x 600) indoor air conditioning system provides high-performance heating and cooling in an elegant design with features such as:

- **Tasteful design and compact, lightweight build.** Create a polished ambiance with a discreetly sized design and a choice of attractive panel patterns.
- **Enhanced comfort control.** Optimize comfort and save energy with optional motion detection.
- **Low maintenance and powerful airflow.** Ease installation and maintenance and maximize airflow with an efficient design and robust performance.

Wind-Free 4Way Cassette (600 x 600) - Tasteful design, Compact, Lightweight build

Refine the interior with an elegant, compact design

The enhanced Samsung Wind-Free 4Way Cassette (600 x 600) indoor air conditioner features a selection of simple panel patterns to blend seamlessly into any interior design. Its uniquely lightweight frame blends effortlessly and beautifully into any décor, while clever blade construction keeps the unit clean for a tidy appearance.

Attractive panel and display

The Wind-Free 4Way Cassette (600 x 600) features a fashionable panel with a simple, beveled corner design. The rounded panel frame promotes a neat, tidy look for an aesthetic flair that blends perfectly with any ambience.

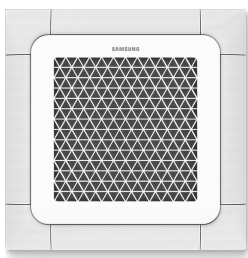

Ultra-compact size

Samsung's Wind-Free 4Way Cassette (600 x 600) air conditioner can be installed on a single standard ceiling tile (600W x 600D) which helps minimize installation time and effort.

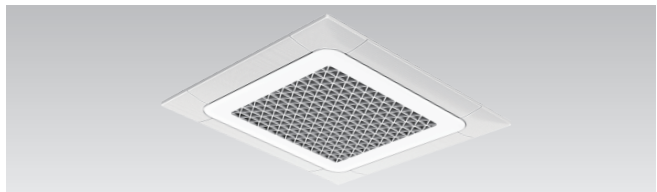

Light, robust design

The Samsung Wind-Free 4Way Cassette (600 x 600) indoor unit is now lighter in weight at 11kg. It is the lightest indoor unit in the industry, about 35 percent lighter than our conventional products.

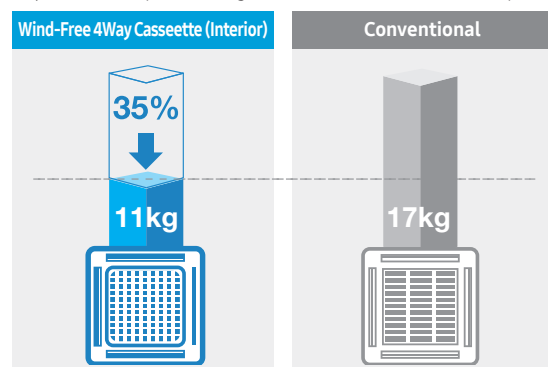

*Based on 3.5kW

1. Specification

Wind-Free 4Way Cassette (600x600)

	Model Name		Indoor Unit	AC026RNNDKG/EU	AC035RNNDKG/EU	
			Outdoor Unit	AC026RXADKG/EU	AC035RXADKG/EU	
System	Mode		-	HEAT PUMP	HEAT PUMP	
	Performance	Capacity (Min/Std/Max)	Cooling	kW	0.87 / 2.60 / 4.10	0.88 / 3.50 / 4.50
				Btu/h	2,970 / 8,870 / 13,990	3,000 / 11,940 / 15,350
		Heating	kW	0.98 / 3.40 / 4.10	1.00 / 4.00 / 4.80	
			Btu/h	3,340 / 11,600 / 13,990	3,410 / 13,650 / 16,380	
	Power	Power Input (Min/Std/Max)	Cooling	kW	0.16 / 0.67 / 1.20	0.18 / 1.03 / 1.40
			Heating	kW	0.20 / 0.92 / 1.45	0.19 / 1.20 / 1.80
		Current Input (Min/Std/Max)	Cooling	A	1.3 / 3.5 / 5.5	1.4 / 5.0 / 6.0
			Heating	A	1.3 / 4.6 / 7.0	1.3 / 5.7 / 10.5
	Current	MCA	A	11.0	11.0	
		MFA	A	12.5	12.5	
	Efficiency	EER	Cooling	-	3.88	3.40
		COP	Heating	-	3.69	3.33
		SEER (Cooling Energy Grade)		-	7.1 (A++)	7.0 (A++)
		SCOP (Heating Energy Grade)		-	4.3 (A+)	4.3 (A+)
	Pdesignh		kW	2.1	2.1	
	Piping Connections	Liquid Pipe		Type	Flare connection	Flare connection
				Φ, mm (inch)	6.35 (1/4)	6.35 (1/4)
		Gas Pipe		Type	Flare connection	Flare connection
				Φ, mm (inch)	9.52 (3/8)	9.52 (3/8)
Heat Insulation		-	Both liquid and gas pipes	Both liquid and gas pipes		
Piping length (ODU-IDU)		Standard	m	5	5	
	Max.		20	20		
	Elevation		15	15		
	Chargeless		20	20		
Wiring connections	Communication	Min.	mm ²	0.75	0.75	
		Remark	-	F1, F2	F1, F2	
Refrigerant	Type		-	R32	R32	
	Factory Charging		kg	0.9	0.9	
tCO ₂ e			0.61	0.61		
Indoor Unit	Power Supply		Ø, #, V, Hz	1,2,220-240,50	1,2,220-240,50	
	Heat Exchanger	Type		-	F&T	F&T
		Material	Fin	-	Al	Al
			Tube	-	Cu	Cu
	Fin Treatment		-	Green Hydrophile	Green Hydrophile	
	Fan	Type		-	Turbo Fan	Turbo Fan
		Quantity		EA	1	1
		Air Flow Rate	Cooling (H/M/L)	m ³ /min	8.0 / 7.0 / 6.0	9.2 / 8.0 / 6.4
				l/s	133.3 / 116.6 / 100	153.3 / 133.3 / 106.6
	Heating (H/M/L)	m ³ /min	10.0 / 9.0 / 8.0	10.4 / 9.0 / 7.8		
l/s		166.6 / 150 / 133.3	173.3 / 150 / 130			
Fan Motor	Type		-	BLDC	BLDC	
	Output		W x n	65	65	

1. Specification

Wind-Free 4Way Cassette (600x600)

Model Name	Indoor Unit			AC026RNNDKG/EU	AC035RNNDKG/EU
	Outdoor Unit			AC026RXADKG/EU	AC035RXADKG/EU
Drain	Drain Pipe		Φ, mm	VP-25(OD32, ID25)	VP-25(OD32, ID25)
Sound	Sound Pressure Level	High/Mid/Low/(Silent)	dB(A)	31 / 28 / 25	34 / 30 / 25
	Sound Power Level		dB(A)	48	50
External Dimension	Net Weight		kg	11.5	11.5
	Shipping Weight		kg	14.0	14.0
	Net Dimensions (WxHxD)		mm	575 x 250 x 575	575 x 250 x 575
	Shipping Dimensions (WxHxD)		mm	623 x 298 x 653	623 x 298 x 653
Casing	Material		-	Polypropylene	Polypropylene
Panel (1)	Model Name		-	PC4SUFMAN	PC4SUFMAN
	Type		-	Wind-Free Type	Wind-Free Type
	Material		-	HIPS	HIPS
	Color		-	DA White	DA White
	Net Weight		kg	2.7	2.7
	Shipping Weight		kg	3.9	3.9
	Net Dimensions (WxHxD)		mm	620 x 46 x 620	620 x 46 x 620
	Shipping Dimensions (WxHxD)		mm	670 x 120 x 655	670 x 120 x 655
Panel (2)	Model Name		-	PC4SUSMBN	PC4SUSMBN
	Type		-	Waffle Type	Waffle Type
	Material		-	HIPS	HIPS
	Color		-	Victory gray	Victory gray
	Net Weight		kg	2.3	2.3
	Shipping Weight		kg	3.5	3.5
	Net Dimensions (WxHxD)		mm	620 x 45 x 620	620 x 45 x 620
	Shipping Dimensions (WxHxD)		mm	661 x 106 x 671	661 x 106 x 671
Panel (3)	Model Name		-	PC4SUSMFN	PC4SUSMFN
	Type		-	Stripe Type	Stripe Type
	Material		-	HIPS	HIPS
	Color		-	Victory gray	Victory gray
	Net Weight		kg	2.3	2.3
	Shipping Weight		kg	3.5	3.5
	Net Dimensions (WxHxD)		mm	620 x 45 x 620	620 x 45 x 620
	Shipping Dimensions (WxHxD)		mm	661 x 106 x 671	661 x 106 x 671
Control System	Infrared remote control		-	AR-EH03E	AR-EH03E
	Wired remote control		-	MWR-WE13N MWR-WG00*N	MWR-WE13N MWR-WG00*N
Drain Pump	Drain Pump		-	Included	Included
	Max. lifting Height / Displacement		mm / Liter / h	750/24	750/24
Additional Accessories	Drain Pump	External Model	-	-	-
		Internal Model	-	-	-
	Max. lifting Height / Displacement		mm / Liter / h	-	-
	Air Filter		-	Removable / Washable	Removable / Washable
	Virus Doctor		-	Option	-

1. Specification

Wind-Free 4Way Cassette (600x600)

Model Name	Indoor Unit			AC026RNNDKG/EU	AC035RNNDKG/EU	
	Outdoor Unit			AC026RXADKG/EU	AC035RXADKG/EU	
Power Supply				Ø, #, V, Hz	1, 2, 220-240, 50	
Heat Exchanger	Type		-	Fin & Tube	Fin & Tube	
	Material	Fin	-	Al	Al	
		Tube	-	Cu	Cu	
	Fin Treatment		-	Anti-Corrosion	Anti-Corrosion	
Compressor	Model Name			UB9AK5090FER	UB9AK5090FER	
	Type			Single BLDC	Single BLDC	
	Output			kW	0.86	
	Oil	Type		-	POE	POE
		Initial charge		cc	320	320
Fan	Type		-	Propeller	Propeller	
	Discharge direction		-	Front	Front	
	Quantity		EA	1	1	
	Air Flow Rate		m ³ /min	29	30	
			l/s	483	500	
Fan Motor	Type			BLDC Motor	BLDC Motor	
	Output			W x n	40 x 1	
Sound	Sound Pressure Level	Cooling	dB(A)	46	48	
		Heating	dB(A)	47	48	
	Sound Power Level		dB(A)	59	61	
External Dimension	Net Weight		kg	32.5	32.5	
	Shipping Weight		kg	35.5	35.5	
	Net Dimensions (WxHxD)		mm	790 x 548 x 285	790 x 548 x 285	
	Shipping Dimensions (WxHxD)		mm	913 x 622 x 371	913 x 622 x 371	
Casing	Material	Body	-	EGL Steel Plate	EGL Steel Plate	
	Operating Temp. Range			°C	-15 ~ 46	
	Heating			°C	-20 ~ 24	

NOTE

- Specification may be subject to change without prior notice.
 - 1) Performances are based on the following test conditions.
 - Cooling : Indoor temperature 27°C DB, 19°C WB, Outdoor temperature 35°C DB, 24°C WB
 - Heating : Indoor temperature 20°C DB, 15°C WB, Outdoor temperature 7°C DB, 6°C WB
 - Equivalent refrigerant pipe length 5m, Level differences 0m
 - 2) Select wire size based on the value of MCA
 - 3) Sound pressure level is obtained in an anechoic room.
 - Sound pressure level is a relative value, depending on the distance and acoustic environment.
 - Sound pressure level may differ depending on operation condition.
 - dBA = A-weighted sound pressure level
 - Reference acoustic pressure 0 dB = 20uPa
 - 4) Sound power level is an absolute value that a sound source generates.
 - dBA = A-weighted sound power level
 - Reference power : 1pW
 - Measured according to ISO 3741
 - 5) These products contain R32(GWP=675) which is fluorinated greenhouse gas.
 - 6) 'MWR-WG00*N' is new wired remote control type(Graphic).
If you need the latest control system information, please refer to SAC control TDB.

1. Specification

Wind-Free 4Way Cassette (600x600)

Model Name	Indoor Unit			AC052RNNDKG/EU	AC071RNNDKG/EU	
	Outdoor Unit			AC052RXADKG/EU	AC071RXADKG/EU	
Mode				-	HEAT PUMP	
Performance	Capacity (Min/Std/Max)	Cooling	kW	1.30 / 5.00 / 6.20	1.50 / 6.80 / 8.30	
			Btu/h	4,430 / 17,060 / 21,150	5,120 / 23,200 / 28,320	
		Heating	kW	1.30 / 5.50 / 7.50	1.90 / 7.50 / 9.00	
			Btu/h	4,430 / 18,760 / 25,590	6,480 / 25,590 / 30,710	
Power	Power Input (Min/Std/Max)	Cooling	kW	0.31 / 1.53 / 2.10	0.35 / 2.75 / 3.60	
		Heating	kW	0.35 / 1.52 / 2.40	0.35 / 2.80 / 3.95	
	Current Input (Min/Std/Max)	Cooling	A	2.6 / 7.0 / 9.5	2.0 / 12.0 / 16.0	
		Heating	A	2.9 / 7.0 / 11.0	2.0 / 12.0 / 17.0	
	Current	MCA	A	17.5	17.5	
		MFA	A	20.6	20.6	
Efficiency	EER	Cooling	-	3.27	2.47	
	COP	Heating	-	3.62	2.68	
	SEER (Cooling Energy Grade)		-	6.7 (A++)	6.1 (A++)	
	SCOP (Heating Energy Grade)		-	4.2 (A+)	3.8 (A)	
	Pdesignh		kW	2.4	4.0	
Piping Connections	Liquid Pipe		Type	Flare connection	Flare connection	
			Φ, mm (inch)	6.35 (1/4)	6.35 (1/4)	
	Gas Pipe		Type	Flare connection	Flare connection	
			Φ, mm (inch)	12.7 (1/2)	15.88 (5/8)	
	Heat Insulation		-	Both liquid and gas pipes	Both liquid and gas pipes	
	Piping length (ODU-IDU)	Standard	m	5	5	
		Max.	m	30	50	
Elevation		m	20	30		
Chargeless		m	10	15		
Wiring connections	Communication	Min.	mm ²	0.75	0.75	
		Remark	-	F1, F2	F1, F2	
Refrigerant	Type		-	R32	R32	
	Factory Charging		kg	1.2	1.7	
			tCO ₂ e	0.81	1.15	
Power Supply				Ø, #, V, Hz	1,2,220-240,50	1,2,220-240,50
Heat Exchanger	Type		-	F&T	F&T	
	Material	Fin	-	Al	Al	
		Tube	-	Cu	Cu	
Fin Treatment		-	Green Hydrophile	Green Hydrophile		
Fan	Type		-	Turbo Fan	Turbo Fan	
	Quantity		EA	1	1	
	Air Flow Rate	Cooling (H/M/L)	m ³ /min	10.5 / 9.5 / 8.5	11.5 / 10.5 / 9.5	
			l/s	175 / 158.3 / 141.6	191.6 / 175 / 158.3	
		Heating (H/M/L)	m ³ /min	10.5 / 9.5 / 8.5	11.5 / 10.5 / 9.5	
l/s			175 / 158.3 / 141.6	191.6 / 175 / 158.3		
Fan Motor	Type		-	BLDC	BLDC	
	Output		W x n	65	65	

1. Specification

Wind-Free 4Way Cassette (600x600)

Model Name	Indoor Unit			AC052RNNDKG/EU	AC071RNNDKG/EU
	Outdoor Unit			AC052RXADKG/EU	AC071RXADKG/EU
Drain	Drain Pipe		Φ, mm	VP-25(OD32, ID25)	VP-25(OD32, ID25)
Sound	Sound Pressure Level	High/Mid/Low/(Silent)	dB(A)	39 / 34 / 29	42 / 39 / 36
	Sound Power Level		dB(A)	56	58
External Dimension	Net Weight		kg	12.0	12.0
	Shipping Weight		kg	14.2	14.2
	Net Dimensions (WxHxD)		mm	575 x 250 x 575	575 x 250 x 575
	Shipping Dimensions (WxHxD)		mm	623 x 298 x 653	623 x 298 x 653
Casing	Material		-	Polypropylene	Polypropylene
Panel (1)	Model Name		-	PC4SUFMAN	PC4SUFMAN
	Type		-	Wind-Free Type	Wind-Free Type
	Material		-	HIPS	HIPS
	Color		-	DA White	DA White
	Net Weight		kg	2.7	2.7
	Shipping Weight		kg	3.9	3.9
	Net Dimensions (WxHxD)		mm	620 x 46 x 620	620 x 46 x 620
	Shipping Dimensions (WxHxD)		mm	670 x 120 x 655	670 x 120 x 655
Panel (2)	Model Name		-	PC4SUSMBN	PC4SUSMBN
	Type		-	Waffle Type	Waffle Type
	Material		-	HIPS	HIPS
	Color		-	Victory gray	Victory gray
	Net Weight		kg	2.3	2.3
	Shipping Weight		kg	3.5	3.5
	Net Dimensions (WxHxD)		mm	620 x 45 x 620	620 x 45 x 620
	Shipping Dimensions (WxHxD)		mm	661 x 106 x 671	661 x 106 x 671
Panel (3)	Model Name		-	PC4SUSMFN	PC4SUSMFN
	Type		-	Stripe Type	Stripe Type
	Material		-	HIPS	HIPS
	Color		-	Victory gray	Victory gray
	Net Weight		kg	2.3	2.3
	Shipping Weight		kg	3.5	3.5
	Net Dimensions (WxHxD)		mm	620 x 45 x 620	620 x 45 x 620
	Shipping Dimensions (WxHxD)		mm	661 x 106 x 671	661 x 106 x 671
Control System	Infrared remote control		-	AR-EH03E	AR-EH03E
	Wired remote control		-	MWR-WE13N MWR-WG00*N	MWR-WE13N MWR-WG00*N
Drain Pump	Drain Pump		-	Included	Included
	Max. lifting Height / Displacement		mm / Liter / h	750/24	750/24
Additional Accessories	Drain Pump	External Model	-	-	-
		Internal Model	-	-	-
	Max. lifting Height / Displacement		mm / Liter / h	-	-
	Air Filter		-	Removable / Washable	Removable / Washable
	Virus Doctor		-	Option	Option

1. Specification

Wind-Free 4Way Cassette (600x600)

Model Name	Indoor Unit		AC052RNNDKG/EU	AC071RNNDKG/EU
	Outdoor Unit		AC052RXADKG/EU	AC071RXADKG/EU
Power Supply		Ø, #, V, Hz	1, 2, 220-240, 50	1, 2, 220-240, 50
Heat Exchanger	Type		-	Fin & Tube
	Material	Fin	-	Al
		Tube	-	Cu
Fin Treatment		-	Anti-Corrosion	Anti-Corrosion
Compressor	Model Name		UB9TK3150FE4	UG4T200FUA4
	Type		-	Twin BLDC
	Output		kW	1.51
	Oil	Type	-	POE
Initial charge		cc	500	
Fan	Type		-	Propeller
	Discharge direction		-	Front
	Quantity		EA	1
	Air Flow Rate			m ³ /min
		l/s	667	
Fan Motor	Type		-	BLDC Motor
	Output		W x n	125 x 1
Sound	Sound Pressure Level	Cooling	dB(A)	48
		Heating	dB(A)	48
	Sound Power Level		dB(A)	62
External Dimension	Net Weight		kg	43.5
	Shipping Weight		kg	46.5
	Net Dimensions (WxHxD)		mm	880 x 638 x 310
	Shipping Dimensions (WxHxD)		mm	1,023 x 742 x 413
Casing	Material	Body	-	EGI Steel Plate
			-	EGI Steel Plate
Operating Temp. Range	Cooling		°C	-15 ~ 50
	Heating		°C	-20 ~ 24

NOTE

- Specification may be subject to change without prior notice.
- 1) Performances are based on the following test conditions.
 - Cooling : Indoor temperature 27°C DB, 19°C WB, Outdoor temperature 35°C DB, 24°C WB
 - Heating : Indoor temperature 20°C DB, 15°C WB, Outdoor temperature 7°C DB, 6°C WB
 - Equivalent refrigerant pipe length 5m, Level differences 0m
- 2) Select wire size based on the value of MCA
- 3) Sound pressure level is obtained in an anechoic room.
 - Sound pressure level is a relative value, depending on the distance and acoustic environment.
 - Sound pressure level may differ depending on operation condition.
 - dBA = A-weighted sound pressure level
 - Reference acoustic pressure 0 dB = 20uPa
- 4) Sound power level is an absolute value that a sound source generates.
 - dBA = A-weighted sound power level
 - Reference power : 1pW
 - Measured according to ISO 3741
- 5) These products contain R32(GWP=675) which is fluorinated greenhouse gas.
- 6) 'MWR-WG00*N' is new wired remote control type(Graphic).
If you need the latest control system information, please refer to SAC control TDB.

2. Summary Table

Wind-Free 4Way Cassette (600x600)

Performance Characteristics

Model Code	Net Weight (kg)	Capacity			Fan Speed	Airflow (CMM)	Sound Pressure Level (dBA)	Sound Power Level (dBA)
			Cooling (kW)	Heating (kW)				
AC026RNNDKG/EU	11.4	Max.	4.10	4.10	High	8.0	31	48
		Std.	2.60	3.40	Mid	7.0	28	
		Min.	0.87	0.98	Low	6.0	25	
AC035RNNDKG/EU	11.4	Max.	4.50	4.80	High	9.2	34	50
		Std.	3.50	4.00	Mid	8.0	30	
		Min.	0.88	1.00	Low	6.4	25	
AC052RNNDKG/EU	11.6	Max.	6.20	7.50	High	10.5	39	56
		Std.	5.00	5.50	Mid	9.5	34	
		Min.	1.30	1.30	Low	8.5	29	
AC071RNNDKG/EU	11.8	Max.	8.30	9.00	High	11.5	42	58
		Std.	6.80	7.50	Mid	10.5	39	
		Min.	1.50	1.90	Low	9.5	36	

NOTE

- Sound data is based on cooling operation.

Electric Characteristics

Model		Outdoor Unit				Input Current (Amperes)				Power Supply	
Indoor Unit	Outdoor Unit	Rated	Voltage range			Outdoor Unit		Indoor Unit	Total	MCA(A)	MFA(A)
		Hz	Volts	Min.	Max.	Cooling	Heating				
AC026RNNDKG/EU	AC026RXADKG/EU	50	220 to 240	198	264	10	10	1.0	11.0	11.0	12.5
AC035RNNDKG/EU	AC035RXADKG/EU	50	220 to 240	198	264	10	10	1.0	11.0	11.0	12.5
AC052RNNDKG/EU	AC052RXADKG/EU	50	220 to 240	198	264	16.5	16.5	1.0	17.5	17.5	20.6
AC071RNNDKG/EU	AC071RXADKG/EU	50	220 to 240	198	264	16.5	16.5	1.0	17.5	17.5	20.6

NOTE

- MCA : Minimum circuit amperes
- MFA : Maximum fuse amperes
- Select wire size based on the value of MCA

3. Capacity Table

Wind-Free 4Way Cassette (600x600)

(1) AC026RNNDKG/EU+AC026RXADKG/EU

Cooling

TC : Total Capacity, SHC : Sensible Heat Capacity, PI : Power Input

Outdoor Temperature (°C, DB)	Indoor Temperature (°C, DB / WB)																				
	20 / 14			22 / 16			25 / 18			27 / 19			28 / 20			30 / 22			32 / 24		
	TC	SHC	PI	TC	SHC	PI	TC	SHC	PI	TC	SHC	PI	TC	SHC	PI	TC	SHC	PI	TC	SHC	PI
	kW	kW	kW	kW	kW	kW	kW	kW	kW	kW	kW	kW	kW	kW	kW	kW	kW	kW	kW	kW	kW
-15	2.5	2.1	0.48	2.7	2.2	0.49	2.8	2.2	0.50	2.9	2.3	0.51	2.9	2.3	0.51	3.1	2.3	0.52	3.2	2.2	0.53
21	2.4	2.0	0.50	2.5	2.1	0.51	2.6	2.1	0.53	2.7	2.2	0.54	2.8	2.2	0.54	2.9	2.2	0.55	3.1	2.1	0.56
35	2.3	1.9	0.63	2.4	2.0	0.64	2.5	2.0	0.66	2.6	2.1	0.67	2.7	2.1	0.68	2.8	2.1	0.68	2.9	2.0	0.70
46	2.0	1.8	0.57	2.1	1.8	0.58	2.1	1.9	0.59	2.2	1.9	0.60	2.3	1.9	0.61	2.4	1.9	0.62	2.5	1.9	0.63

Heating

TC : Total Capacity, PI : Power Input

Outdoor Temperature (°C, DB)	Indoor Temperature (°C, DB)											
	16		18		20		21		22		24	
	TC	PI	TC	PI	TC	PI	TC	PI	TC	PI	TC	PI
	kW	kW	kW	kW	kW	kW	kW	kW	kW	kW	kW	kW
-20	2.4	1.22	2.4	1.21	2.3	1.20	2.3	1.18	2.3	1.17	2.3	1.16
-15	3.0	1.41	3.0	1.39	3.0	1.38	2.9	1.37	2.9	1.35	2.9	1.34
-5	3.4	1.31	3.4	1.30	3.3	1.29	3.3	1.28	3.3	1.26	3.2	1.25
0	3.5	1.13	3.5	1.12	3.5	1.10	3.4	1.09	3.4	1.08	3.4	1.07
7	3.5	0.94	3.4	0.93	3.4	0.92	3.4	0.91	3.3	0.90	3.3	0.89
24	4.5	1.08	4.5	1.07	4.4	1.06	4.4	1.05	4.3	1.04	4.3	1.03

NOTE

- The performance table shows the average value of each conditions.

3. Capacity Table

Wind-Free 4Way Cassette (600x600)

(2) AC035RNNDKG/EU+AC035RXADKG/EU

Cooling

TC : Total Capacity, SHC : Sensible Heat Capacity, PI : Power Input

Outdoor Temperature (°C, DB)	Indoor Temperature (°C, DB / WB)																				
	20 / 14			22 / 16			25 / 18			27 / 19			28 / 20			30 / 22			32 / 24		
	TC	SHC	PI	TC	SHC	PI	TC	SHC	PI	TC	SHC	PI	TC	SHC	PI	TC	SHC	PI	TC	SHC	PI
	kW	kW	kW	kW	kW	kW	kW	kW	kW	kW	kW	kW	kW	kW	kW	kW	kW	kW	kW	kW	kW
-15	3.4	2.6	0.74	3.6	2.7	0.75	3.7	2.8	0.77	3.9	2.9	0.78	3.9	2.8	0.79	4.1	2.8	0.80	4.3	2.8	0.81
21	3.3	2.5	0.78	3.4	2.6	0.79	3.6	2.6	0.81	3.7	2.7	0.82	3.7	2.7	0.83	3.9	2.7	0.84	4.1	2.6	0.86
35	3.1	2.4	0.97	3.3	2.4	0.99	3.4	2.5	1.01	3.5	2.6	1.03	3.6	2.6	1.04	3.7	2.5	1.05	3.9	2.5	1.07
46	2.6	2.3	0.87	2.8	2.3	0.89	2.9	2.4	0.91	3.0	2.5	0.93	3.0	2.4	0.94	3.2	2.4	0.95	3.3	2.4	0.96

Heating

TC : Total Capacity, PI : Power Input

Outdoor Temperature (°C, DB)	Indoor Temperature (°C, DB)											
	16		18		20		21		22		24	
	TC	PI	TC	PI	TC	PI	TC	PI	TC	PI	TC	PI
	kW	kW	kW	kW	kW	kW	kW	kW	kW	kW	kW	kW
-20	2.8	1.59	2.8	1.58	2.8	1.56	2.7	1.54	2.7	1.53	2.7	1.51
-15	3.5	1.84	3.5	1.82	3.5	1.80	3.4	1.78	3.4	1.76	3.4	1.75
-5	4.0	1.71	4.0	1.70	3.9	1.68	3.9	1.66	3.8	1.65	3.8	1.63
0	4.2	1.47	4.1	1.45	4.1	1.44	4.0	1.43	4.0	1.41	4.0	1.40
7	4.1	1.22	4.0	1.21	4.0	1.20	4.0	1.19	3.9	1.18	3.9	1.16
24	5.3	1.41	5.3	1.39	5.2	1.38	5.1	1.37	5.1	1.35	5.0	1.34

NOTE

- The performance table shows the average value of each conditions.

3. Capacity Table

Wind-Free 4Way Cassette (600x600)

(3) AC052RNNDKG/EU+AC052RXADKG/EU

Cooling

TC : Total Capacity, SHC : Sensible Heat Capacity, PI : Power Input

Outdoor Temperature (°C, DB)	Indoor Temperature (°C, DB / WB)																				
	20 / 14			22 / 16			25 / 18			27 / 19			28 / 20			30 / 22			32 / 24		
	TC	SHC	PI	TC	SHC	PI	TC	SHC	PI	TC	SHC	PI	TC	SHC	PI	TC	SHC	PI	TC	SHC	PI
	kW	kW	kW	kW	kW	kW	kW	kW	kW	kW	kW	kW	kW	kW	kW	kW	kW	kW	kW	kW	kW
-15	4.9	3.6	1.09	5.1	3.7	1.12	5.3	3.8	1.14	5.5	4.0	1.16	5.6	3.9	1.17	5.9	3.9	1.19	6.2	3.8	1.21
21	4.6	3.4	1.15	4.9	3.6	1.18	5.1	3.7	1.20	5.3	3.8	1.22	5.4	3.7	1.24	5.6	3.7	1.25	5.9	3.6	1.27
35	4.4	3.3	1.44	4.7	3.4	1.47	4.9	3.5	1.50	5.0	3.6	1.53	5.1	3.6	1.55	5.4	3.5	1.56	5.6	3.5	1.59
46	3.8	3.1	1.30	4.0	3.2	1.32	4.1	3.3	1.35	4.3	3.4	1.38	4.3	3.3	1.39	4.6	3.3	1.40	4.8	3.2	1.43
50	2.9	2.4	1.15	3.0	2.5	1.18	3.2	2.6	1.20	3.3	2.7	1.22	3.3	2.6	1.24	3.5	2.6	1.25	3.7	2.6	1.27

Heating

TC : Total Capacity, PI : Power Input

Outdoor Temperature (°C, DB)	Indoor Temperature (°C, DB)											
	16		18		20		21		22		24	
	TC	PI	TC	PI	TC	PI	TC	PI	TC	PI	TC	PI
	kW	kW	kW	kW	kW	kW	kW	kW	kW	kW	kW	kW
-20	3.9	2.02	3.8	2.00	3.8	1.98	3.8	1.96	3.7	1.94	3.7	1.92
-15	4.9	2.33	4.8	2.30	4.8	2.28	4.7	2.26	4.7	2.23	4.6	2.21
-5	5.5	2.17	5.4	2.15	5.4	2.13	5.3	2.11	5.3	2.09	5.2	2.06
0	5.7	1.86	5.7	1.84	5.6	1.82	5.6	1.81	5.5	1.79	5.4	1.77
7	5.6	1.55	5.6	1.54	5.5	1.52	5.4	1.50	5.4	1.49	5.3	1.47
24	7.3	1.78	7.2	1.77	7.2	1.75	7.1	1.73	7.0	1.71	6.9	1.70

NOTE

- The performance table shows the average value of each conditions.

3. Capacity Table

Wind-Free 4Way Cassette (600x600)

(4) AC071RNNDKG/EU+AC071RXADKG/EU

Cooling

TC : Total Capacity, SHC : Sensible Heat Capacity, PI : Power Input

Outdoor Temperature (°C, DB)	Indoor Temperature (°C, DB / WB)																				
	20 / 14			22 / 16			25 / 18			27 / 19			28 / 20			30 / 22			32 / 24		
	TC	SHC	PI	TC	SHC	PI	TC	SHC	PI	TC	SHC	PI	TC	SHC	PI	TC	SHC	PI	TC	SHC	PI
	kW	kW	kW	kW	kW	kW	kW	kW	kW	kW	kW	kW	kW	kW	kW	kW	kW	kW	kW	kW	kW
-15	6.6	4.5	1.97	7.0	4.7	2.01	7.3	4.8	2.05	7.5	5.0	2.09	7.6	4.9	2.11	8.0	4.9	2.13	8.4	4.8	2.17
21	6.3	4.3	2.07	6.6	4.4	2.11	6.9	4.6	2.16	7.1	4.7	2.20	7.3	4.7	2.22	7.6	4.6	2.24	8.0	4.5	2.29
35	6.0	4.1	2.59	6.3	4.2	2.64	6.6	4.4	2.70	6.8	4.5	2.75	6.9	4.5	2.78	7.3	4.4	2.81	7.6	4.3	2.86
46	5.1	3.9	2.33	5.4	4.0	2.38	5.6	4.2	2.43	5.8	4.3	2.48	5.9	4.2	2.50	6.2	4.2	2.52	6.5	4.1	2.57
50	3.9	3.1	2.07	4.1	3.2	2.11	4.3	3.3	2.16	4.4	3.4	2.20	4.5	3.4	2.22	4.7	3.3	2.24	5.0	3.3	2.29

Heating

TC : Total Capacity, PI : Power Input

Outdoor Temperature (°C, DB)	Indoor Temperature (°C, DB)											
	16		18		20		21		22		24	
	TC	PI	TC	PI	TC	PI	TC	PI	TC	PI	TC	PI
	kW	kW	kW	kW	kW	kW	kW	kW	kW	kW	kW	kW
-20	5.3	3.71	5.2	3.68	5.2	3.64	5.1	3.60	5.1	3.57	5.0	3.53
-15	6.7	4.28	6.6	4.24	6.5	4.20	6.5	4.16	6.4	4.12	6.3	4.08
-5	7.5	4.00	7.4	3.96	7.4	3.92	7.3	3.88	7.2	3.84	7.1	3.80
0	7.8	3.43	7.7	3.39	7.7	3.36	7.6	3.33	7.5	3.29	7.4	3.26
7	7.7	2.86	7.6	2.83	7.5	2.80	7.4	2.77	7.4	2.74	7.3	2.72
24	9.9	3.28	9.8	3.25	9.8	3.22	9.7	3.19	9.6	3.16	9.5	3.12

NOTE

- The performance table shows the average value of each conditions.

4. Dimensional Drawing

Wind-Free 4Way Cassette (600x600)

AC026/035/052/071RNNDKG/EU

Units : mm [inches]

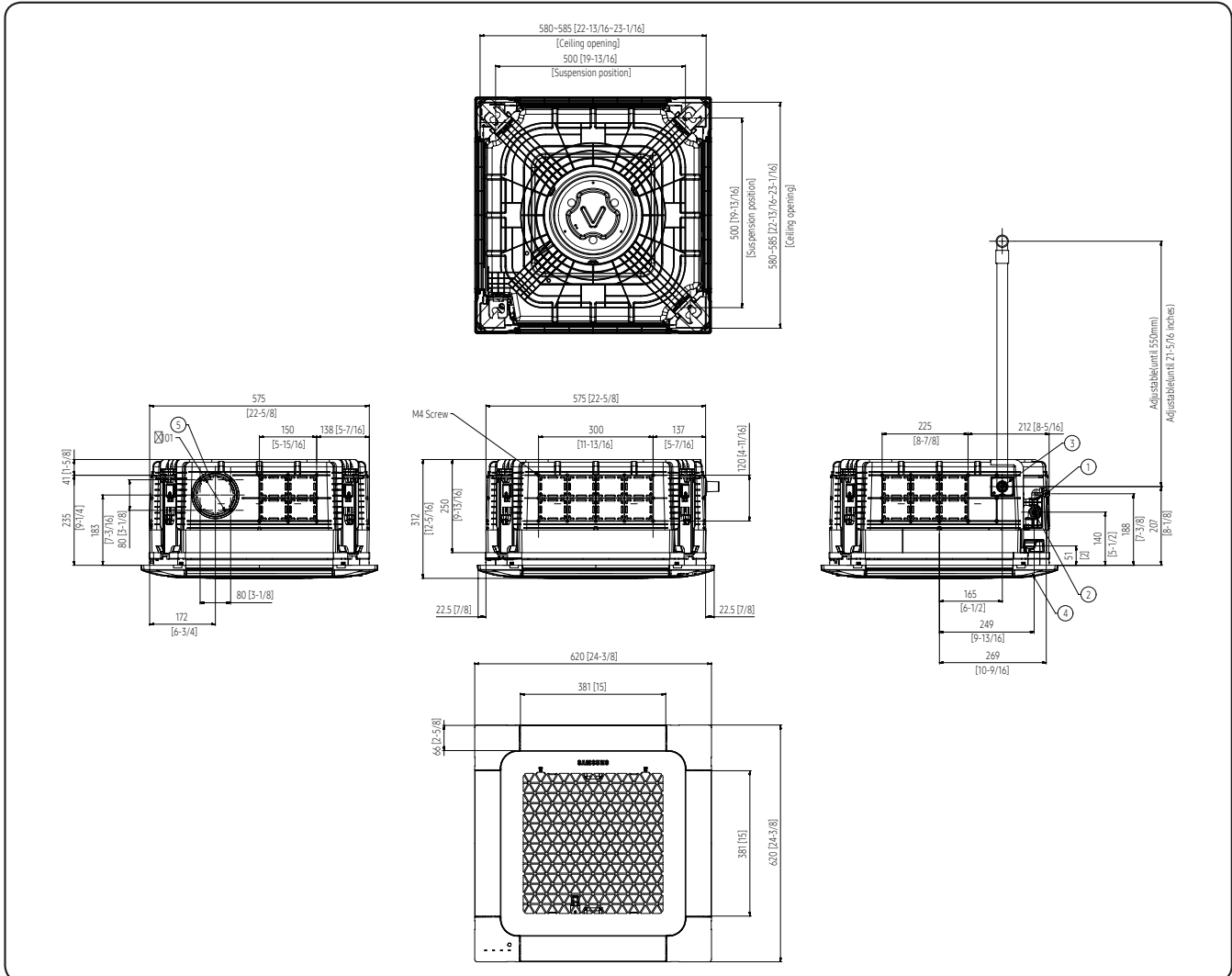

No.	Name	Description		
		AC026/035RNNDKG/EU	AC052RNNDKG/EU	AC071RNNDKG/EU
1	Liquid pipe connection	Φ6.35(1/4)		
2	Gas pipe connection	Φ9.52(3/8)	Φ12.7(1/2)	Φ15.88(3/8)
3	Drain pipe connection	VP-25(OD32, ID25)		
4	Power supply & Communication wiring conduit			
5	Sub duct connection	Use M4 Screw		
6	Fresh air intake knockout hole	Φ10[4] , Use M4 Screw		

NOTE

- As for suspension bolt, please use M8 ~ M10.
(Procured at local site)

5. Center of Gravity

Wind-Free 4Way Cassette (600x600)

AC026/035/052/071RNNDKG/EU

Units : mm [inches]

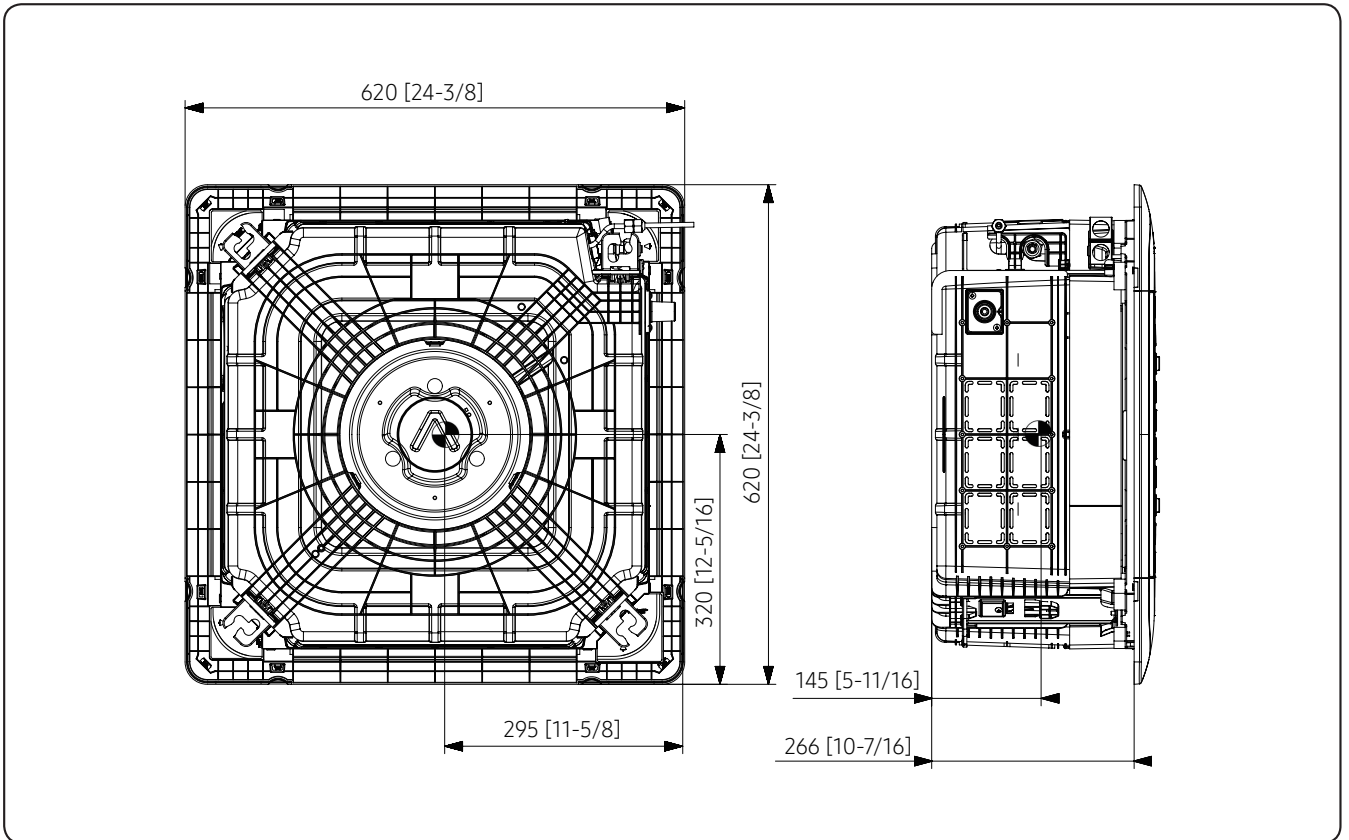

6. Electrical Wiring Diagram

Wind-Free 4Way Cassette (600x600)

AC026/035/052/071RNNDKG/EU

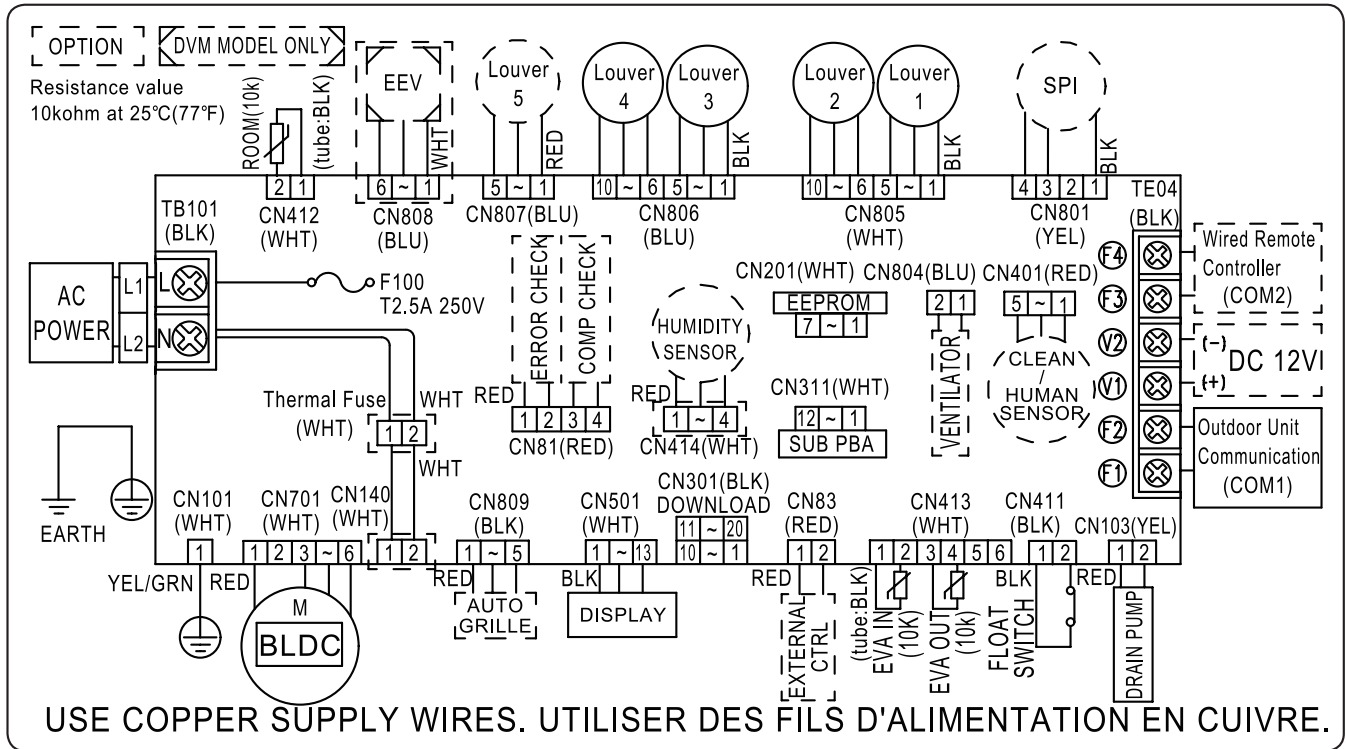

SPI	S-Plasma ion	EEV	Electronic Expansion Valve	ROOM	Thermistor ROOM in (10K)
FLOAT SWITCH	Switch of the float of Drain	EVA-IN	Thermistor EVA IN(10K)	EVA-OUT	Thermistor EVA OUT(10K)

NOTE

- This wiring diagram applies only to the Indoor unit.
- Symbols show as follow :
blk: black, red: red, blu: blue, wht: white, yel: yellow, brn: brown, sky: skyblue: grn: green
- For connection wiring indoor-outdoor transmission F1-F2, indoor-wired remote controller transmission F3-F4.
- Protective earth(screw)

7. Sound Data

Wind-Free 4Way Cassette (600x600)

Sound Pressure level

Unit: dB(A)

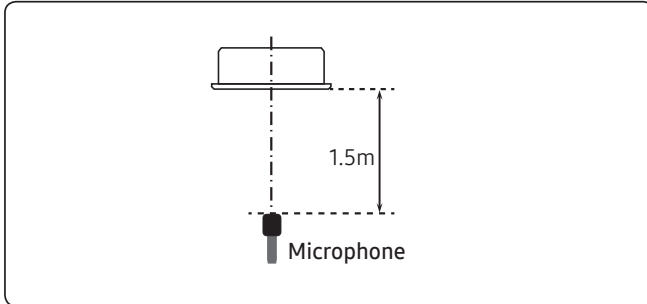

Model	HIGH	MID	LOW
AC026RNNDKG/EU	31	28	25
AC035RNNDKG/EU	34	30	25
AC052RNNDKG/EU	39	34	29
AC071RNNDKG/EU	42	40	36

• NR Curve

1) AC026RNNDKG/EU

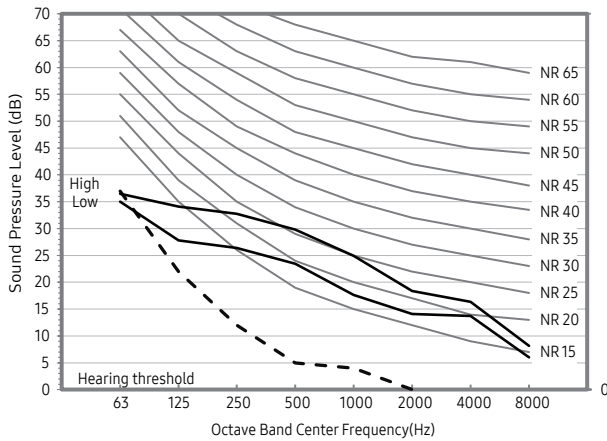

2) AC035RNNDKG/EU

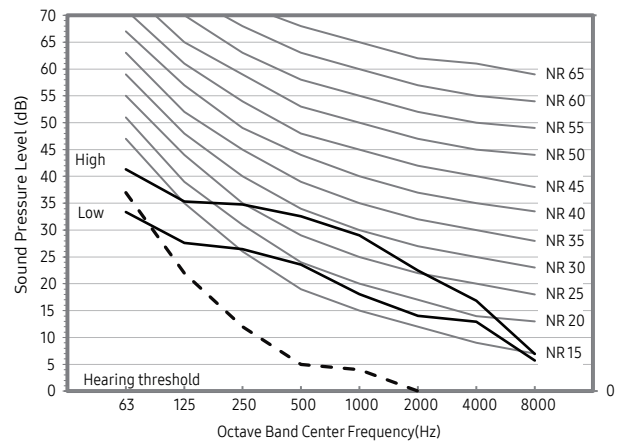

3) AC052RNNDKG/EU

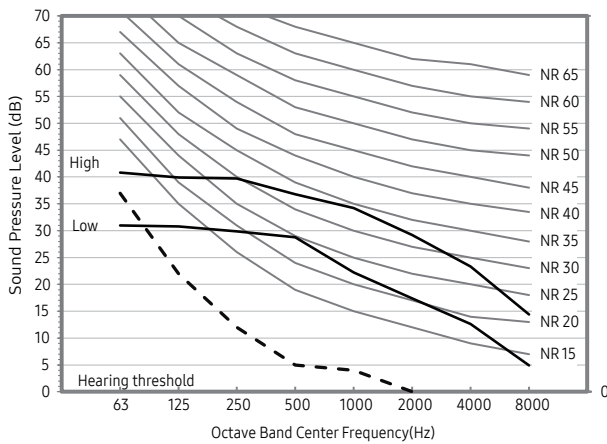

4) AC071RNNDKG/EU

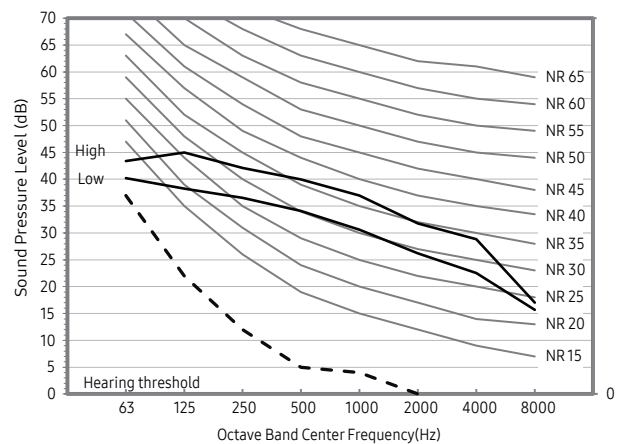

NOTE

- Specifications may be subject to change without prior notice.
 - Sound pressure level is obtained in an anechoic room.
 - Sound pressure level is a relative value, depending on the distance and acoustic environment.
 - Sound pressure level may differ depending on operation condition.
 - dBA = A weighted sound pressure level
 - Reference acoustic pressure 0 dB = 20μPa

7. Sound Data

Wind-Free 4Way Cassette (600x600)

Sound Power level

NOTE

- Specifications may be subject to change without prior notice
 - Sound power level is an absolute value that a sound source generates.
 - dBA = A-weighted sound power level.
 - Reference power : 1pW.
 - Measured according to ISO 3741.

Unit: dB(A)

Model	Power
AC026RNNDKG/EU	48
AC035RNNDKG/EU	50
AC052RNNDKG/EU	56
AC071RNNDKG/EU	58

• NR Curve

1) AC026RNNDKG/EU

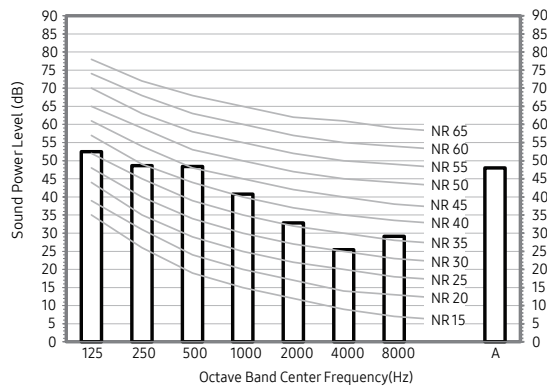

2) AC035RNNDKG/EU

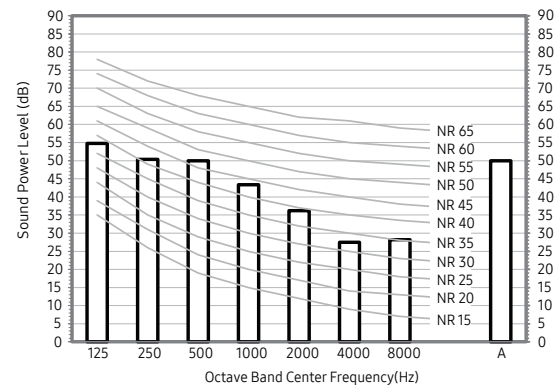

3) AC052RNNDKG/EU

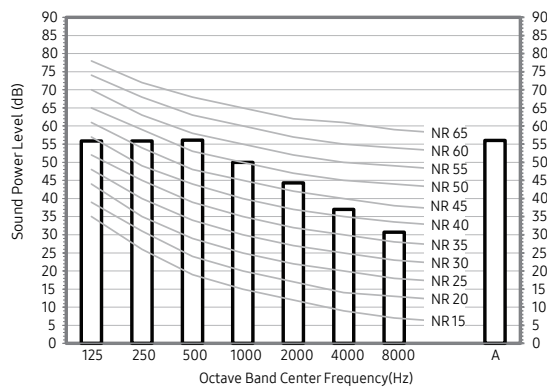

4) AC071RNNDKG/EU

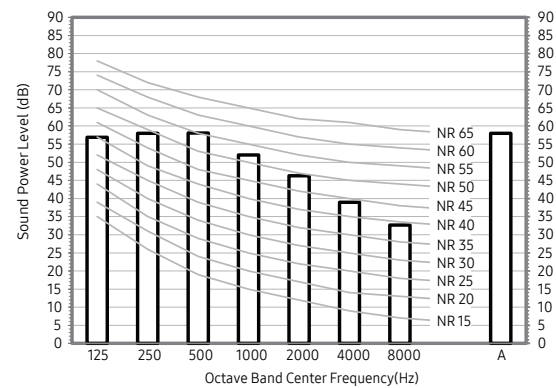

8. Temperature and air flow distribution

Wind-Free 4Way Cassette (600x600)

AC026RNNDKG/EU

- Cooling Air Velocity distribution

(Discharge angle : 41 degree)

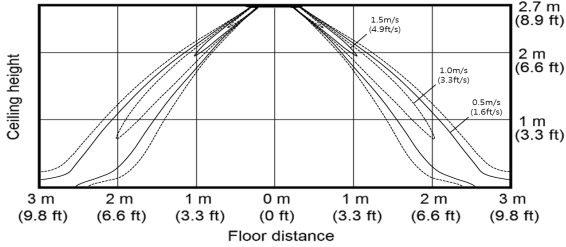

- Cooling temperature distribution

(Discharge angle : 41 degree)

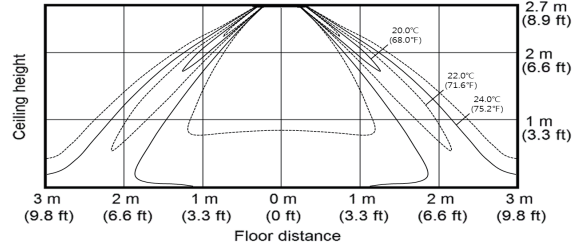

- Heating Air Velocity distribution

(Discharge angle : 56 degree)

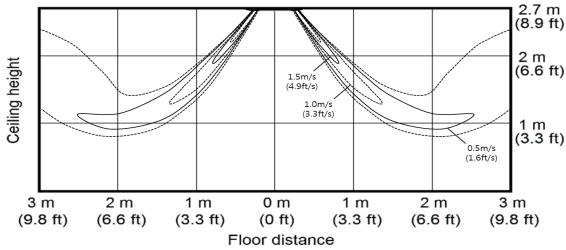

- Heating temperature distribution

(Discharge angle : 56 degree)

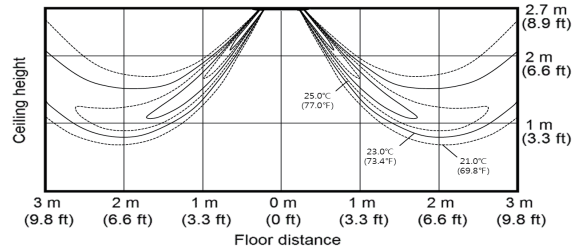

AC035RNNDKG/EU

- Cooling Air Velocity distribution

(Discharge angle : 41 degree)

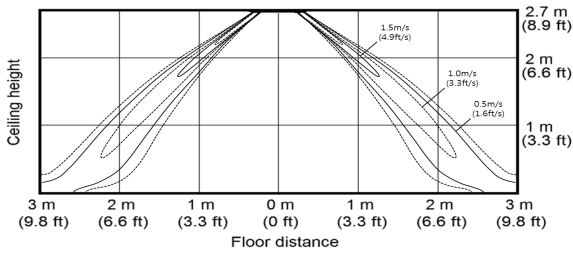

- Cooling temperature distribution

(Discharge angle : 41 degree)

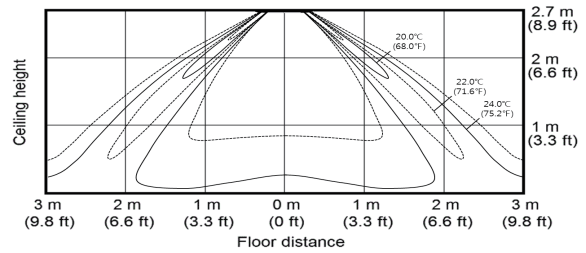

- Heating Air Velocity distribution

(Discharge angle : 56 degree)

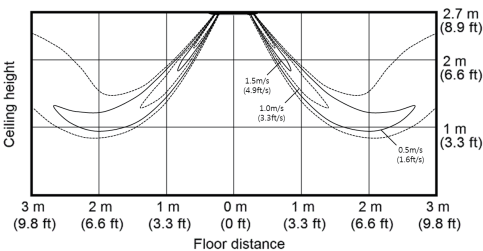

- Heating temperature distribution

(Discharge angle : 56 degree)

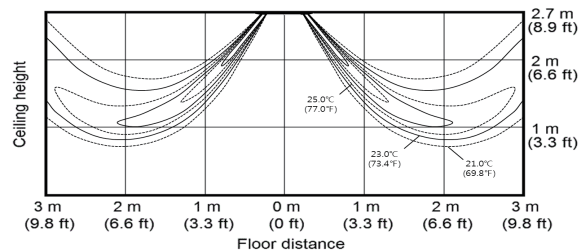

8. Temperature and air flow distribution

Wind-Free 4Way Cassette (600x600)

AC052RNNDKG/EU

- Cooling Air Velocity distribution

(Discharge angle : 41 degree)

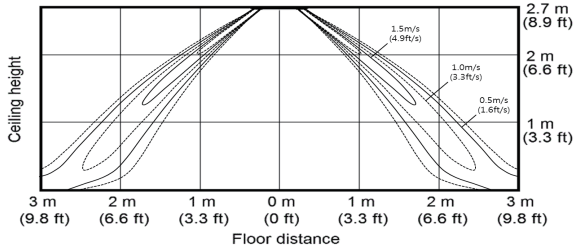

- Cooling temperature distribution

(Discharge angle : 41 degree)

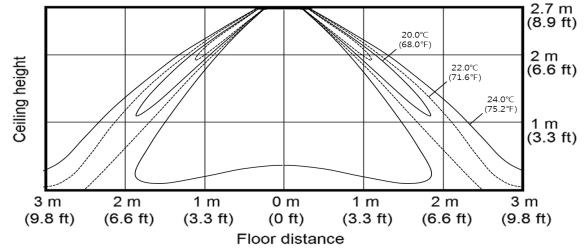

- Heating Air Velocity distribution

(Discharge angle : 56 degree)

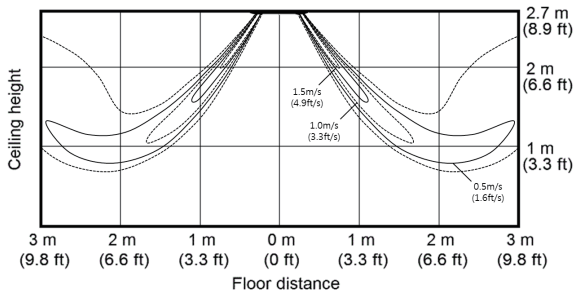

- Heating temperature distribution

(Discharge angle : 56 degree)

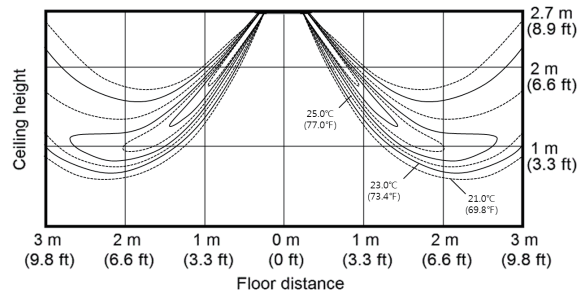

AC071RNNDKG/EU

- Cooling Air Velocity distribution

(Discharge angle : 41 degree)

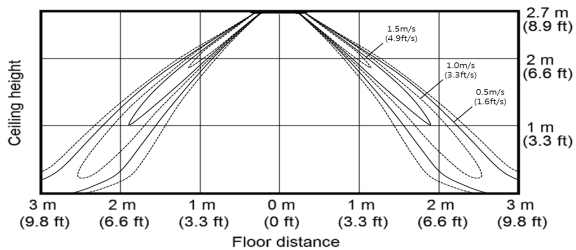

- Cooling temperature distribution

(Discharge angle : 41 degree)

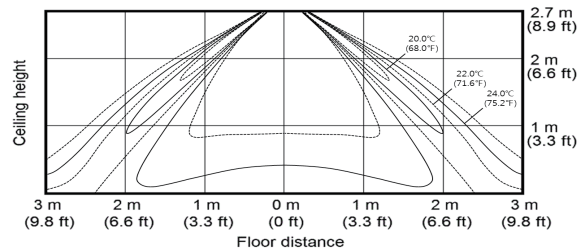

- Heating Air Velocity distribution

(Discharge angle : 56 degree)

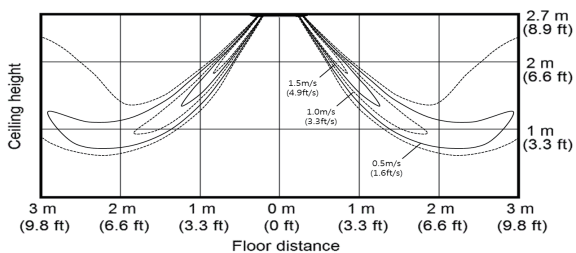

- Heating temperature distribution

(Discharge angle : 56 degree)

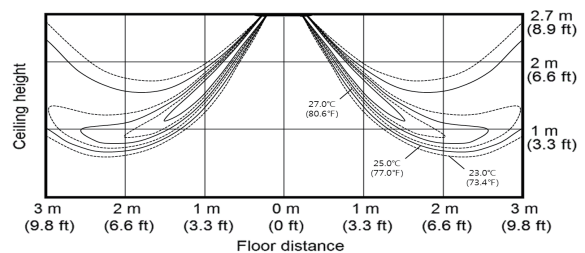

Wind-Free 4Way Cassette

1. Specification	44
2. Summary Table	47
3. Capacity Table	48
4. Dimensional Drawing	50
5. Center of Gravity	51
6. Electrical Wiring Diagram	52
7. Sound Data	53
8. Temperature and air flow distribution	55

Features & Benefits

Wind-Free 4Way Cassette

Add chic flair to your interior design with a stylish yet powerful AC system

Samsung's advanced Wind-Free 4Way Cassette (600 x 600) builds on the aesthetic appeal and performance of the standard Wind-Free 4Way Cassette with an enhanced design. The Wind-Free 4Way Cassette (600 x 600) comes in a variety of patterns to complement any interior. The stylish cassette unit visually harmonizes with the indoor space, while efficient cooling and heating performance make it a dependable and practical air conditioning solution.

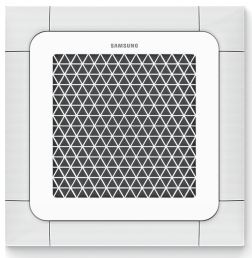

The Wind-Free 4Way Cassette (600 x 600) indoor air conditioning system provides high-performance heating and cooling in an elegant design with features such as:

- **Tasteful design and compact, lightweight build.** Create a polished ambiance with a discreetly sized design and a choice of attractive panel patterns.
- **Enhanced comfort control.** Optimize comfort and save energy with optional motion detection.
- **Low maintenance and powerful airflow.** Ease installation and maintenance and maximize airflow with an efficient design and robust performance.

Wind-Free 4Way Cassette (600 x 600) - Tasteful design, Compact, Lightweight build

Refine the interior with an elegant, compact design

The enhanced Samsung Wind-Free 4Way Cassette (600 x 600) indoor air conditioner features a selection of simple panel patterns to blend seamlessly into any interior design. Its uniquely lightweight frame blends effortlessly and beautifully into any décor, while clever blade construction keeps the unit clean for a tidy appearance.

Attractive panel and display

The Wind-Free 4Way Cassette (600 x 600) features a fashionable panel with a simple, beveled corner design. The rounded panel frame promotes a neat, tidy look for an aesthetic flair that blends perfectly with any ambience.

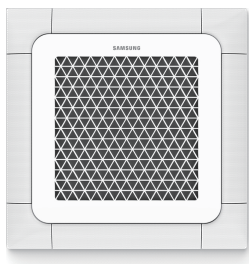

Ultra-compact size

Samsung's Wind-Free 4Way Cassette (600 x 600) air conditioner can be installed on a single standard ceiling tile (600W x 600D) which helps minimize installation time and effort.

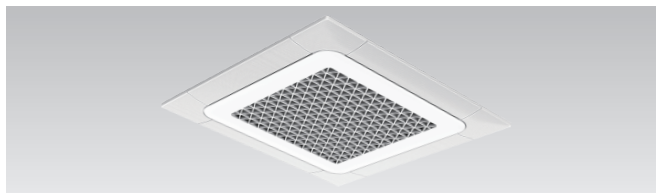

Light, robust design

The Samsung Wind-Free 4Way Cassette (600 x 600) indoor unit is now lighter in weight at 11kg. It is the lightest indoor unit in the industry, about 35 percent lighter than our conventional products.

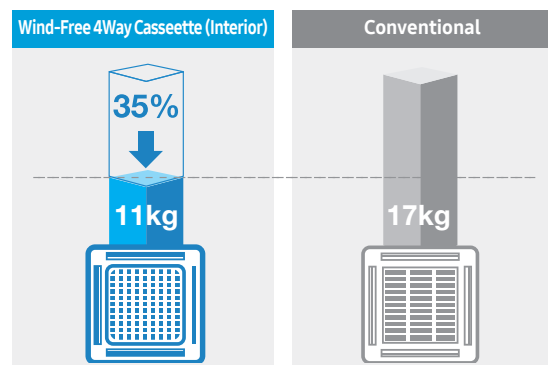

*Based on 3.5kW

1. Specification

Wind-Free 4Way Cassette

	Model Name		Indoor Unit	AC052RN4DKG/EU	AC071RN4DKG/EU	
			Outdoor Unit	AC052RXADKG/EU	AC071RXADKG/EU	
System	Mode		-	HEAT PUMP	HEAT PUMP	
	Performance	Capacity (Min/Std/Max)	Cooling	kW	1.00 / 5.00 / 6.50	1.50 / 7.10 / 8.70
				Btu/h	3,410 / 17,060 / 22,180	5,120 / 24,230 / 29,680
		Heating		kW	1.00 / 6.00 / 7.00	1.90 / 8.00 / 9.00
				Btu/h	3,410 / 20,470 / 23,880	6,480 / 27,300 / 30,710
	Power	Power Input (Min/Std/Max)	Cooling	kW	0.33 / 1.43 / 2.30	0.35 / 2.38 / 3.60
			Heating	kW	0.25 / 1.49 / 2.50	0.35 / 2.45 / 3.95
		Current Input (Min/Std/Max)	Cooling	A	1.5 / 6.5 / 9.5	2.0 / 10.3 / 16.0
			Heating	A	1.5 / 6.8 / 12.0	2.0 / 10.7 / 17.0
		Current	MCA	A	17.5	17.5
			MFA	A	20.6	20.6
	Efficiency	EER	Cooling	-	3.50	2.98
		COP	Heating	-	4.03	3.27
		SEER (Cooling Energy Grade)		-	7.6 (A++)	6.7 (A++)
		SCOP (Heating Energy Grade)		-	4.3 (A+)	4.2 (A+)
		Pdesignh		kW	2.6	4.5
	Piping Connections	Liquid Pipe		Type	Flare connection	Flare connection
				Φ, mm (inch)	6.35 (1/4)	6.35 (1/4)
		Gas Pipe		Type	Flare connection	Flare connection
				Φ, mm (inch)	12.7 (1/2)	15.88 (5/8)
Heat Insulation		-	Both liquid and gas pipes	Both liquid and gas pipes		
Piping length (ODU-IDU)		Standard	Max.	m	5	5
			Elevation	m	30	50
	Chargeless		m	20	30	
	Min.		m	10	15	
Wiring connections	Communication	Min.	mm ²	0.75	0.75	
		Remark	-	F1, F2	F1, F2	
Refrigerant	Type		-	R32	R32	
	Factory Charging		kg	1.2	1.7	
			tCO ₂ e	0.81	1.15	
Indoor Unit	Power Supply		Ø, #, V, Hz	1,2,220-240,50	1,2,220-240,50	
	Heat Exchanger	Type		-	F&T	F&T
		Material	Fin	-	Al	Al
			Tube	-	Cu	Cu
		Fin Treatment		-	Green Hydrophile	Green Hydrophile
	Fan	Type		-	Turbo Fan	Turbo Fan
		Quantity		EA	1	1
		Air Flow Rate	Cooling (H/M/L)	m ³ /min	15.0 / 14.0 / 13.0	19.5 / 16.5 / 14.5
				l/s	250 / 233.3 / 216.6	325 / 275 / 241.6
			Heating (H/M/L)	m ³ /min	15.0 / 14.0 / 13.0	19.5 / 16.5 / 14.5
	l/s			250 / 233.3 / 216.6	325 / 275 / 241.6	
	Fan Motor	Type		-	BLDC	BLDC
		Output		W x n	65	65

1. Specification

Wind-Free 4Way Cassette

Model Name	Indoor Unit			AC052RN4DKG/EU	AC071RN4DKG/EU
	Outdoor Unit			AC052RXADKG/EU	AC071RXADKG/EU
Drain	Drain Pipe		Φ, mm	VP-25(OD32, ID25)	VP-25(OD32, ID25)
Sound	Sound Pressure Level	High/Mid/Low/(Silent)	dB(A)	33 / 31 / 29	36 / 33 / 29
	Sound Power Level		dB(A)	49	53
External Dimension	Net Weight		kg	14.5	14.5
	Shipping Weight		kg	18.5	18.5
	Net Dimensions (WxHxD)		mm	840 x 204 x 840	840 x 204 x 840
	Shipping Dimensions (WxHxD)		mm	898 x 275 x 898	898 x 275 x 898
Casing	Material		-	Polypropylene	Polypropylene
Panel (1)	Model Name		-	PC4NUFMAN	PC4NUFMAN
	Type		-	Wind-Free Type	Wind-Free Type
	Material		-	HIPS	HIPS
	Color		-	DA White	DA White
	Net Weight		kg	6.3	6.3
	Shipping Weight		kg	8.7	8.7
	Net Dimensions (WxHxD)		mm	950 x 48 x 950	950 x 48 x 950
	Shipping Dimensions (WxHxD)		mm	1,010 x 117 x 1,000	1,010 x 117 x 1,000
Panel (2)	Model Name		-	PC4NUSKAN	PC4NUSKAN
	Type		-	Waffle Type	Waffle Type
	Material		-	HIPS	HIPS
	Color		-	White	White
	Net Weight		kg	5.9	5.9
	Shipping Weight		kg	8	8
	Net Dimensions (WxHxD)		mm	950 x 45 x 950	950 x 45 x 950
	Shipping Dimensions (WxHxD)		mm	1,005 x 100 x 1,005	1,005 x 100 x 1,005
Panel (3)	Model Name		-	PC4NBSKAN	PC4NBSKAN
	Type		-	Waffle Type	Waffle Type
	Material		-	HIPS	HIPS
	Color		-	Black	Black
	Net Weight		kg	5.9	5.9
	Shipping Weight		kg	8	8
	Net Dimensions (WxHxD)		mm	950 x 45 x 950	950 x 45 x 950
	Shipping Dimensions (WxHxD)		mm	1,005 x 100 x 1,005	1,005 x 100 x 1,005
Panel (4)	Model Name		-	PC4NUSKEN	PC4NUSKEN
	Type		-	Stripe Type	Stripe Type
	Material		-	ABS	ABS
	Color		-	White	White
	Net Weight		kg	5.9	5.9
	Shipping Weight		kg	8	8
	Net Dimensions (WxHxD)		mm	950 x 45 x 950	950 x 45 x 950
	Shipping Dimensions (WxHxD)		mm	1,005 x 100 x 1,005	1,005 x 100 x 1,005
Control System	Infrared remote control		-	AR-EH03E	AR-EH03E
	Wired remote control		-	MWR-WE13N MWR-WG00*N	MWR-WE13N MWR-WG00*N
Drain Pump	Drain Pump		-	Included	Included
	Max. lifting Height / Displacement		mm / Liter / h	750/24	750/24
Additional Accessories	Drain Pump	External Model	-	-	-
		Internal Model	-	-	-
	Max. lifting Height / Displacement		mm / Liter / h	-	-
	Air Filter		-	Removable / Washable	Removable / Washable
Virus Doctor		-	Option	Option	

1. Specification

Wind-Free 4Way Cassette

Model Name	Indoor Unit			AC052RN4DKG/EU	AC071RN4DKG/EU	
	Outdoor Unit			AC052RXADKG/EU	AC071RXADKG/EU	
Power Supply				Ø, #, V, Hz	1, 2, 220-240, 50	
Heat Exchanger	Type		-	Fin & Tube	Fin & Tube	
	Material	Fin	-	Al	Al	
		Tube	-	Cu	Cu	
	Fin Treatment		-	Anti-Corrosion	Anti-Corrosion	
Compressor	Model Name			UB9TK3150FE4	UB4TN8200FE4	
	Type			Twin BLDC	Twin BLDC	
	Output			kW	1.51	
	Oil	Type		-	POE	POE
		Initial charge		cc	320	320
Fan	Type		-	Propeller	Propeller	
	Discharge direction		-	Front	Front	
	Quantity		EA	1	1	
	Air Flow Rate		m ³ /min	40	51	
			l/s	667	850	
Fan Motor	Type			BLDC Motor	BLDC Motor	
	Output			W x n	125 x 1	
Sound	Sound Pressure Level	Cooling	dB(A)	48	49	
		Heating	dB(A)	48	51	
	Sound Power Level		dB(A)	62	65	
External Dimension	Net Weight		kg	43.5	51.0	
	Shipping Weight		kg	46.5	55.0	
	Net Dimensions (WxHxD)		mm	880 x 638 x 310	880 x 798 x 310	
	Shipping Dimensions (WxHxD)		mm	1,023 x 742 x 413	1,023 x 896 x 413	
Casing	Material	Body	-	EGL Steel Plate	EGL Steel Plate	
	Operating Temp. Range			°C	-15 ~ 50	
	Heating			°C	-20 ~ 24	

NOTE

- Specification may be subject to change without prior notice.
 - 1) Performances are based on the following test conditions.
 - Cooling : Indoor temperature 27°C DB, 19°C WB, Outdoor temperature 35°C DB, 24°C WB
 - Heating : Indoor temperature 20°C DB, 15°C WB, Outdoor temperature 7°C DB, 6°C WB
 - Equivalent refrigerant pipe length 5m, Level differences 0m
 - 2) Select wire size based on the value of MCA
 - 3) Sound pressure level is obtained in an anechoic room.
 - Sound pressure level is a relative value, depending on the distance and acoustic environment.
 - Sound pressure level may differ depending on operation condition.
 - dBA = A-weighted sound pressure level
 - Reference acoustic pressure 0 dB = 20uPa
 - 4) Sound power level is an absolute value that a sound source generates.
 - dBA = A-weighted sound power level
 - Reference power : 1pW
 - Measured according to ISO 3741
 - 5) These products contain R32(GWP=675) which is fluorinated greenhouse gas.
 - 6) 'MWR-WG00*N' is new wired remote control type(Graphic).
If you need the latest control system information, please refer to SAC control TDB.

2. Summary Table

Wind-Free 4Way Cassette

Performance Characteristics

Model Code	Net Weight (kg)	Capacity		Fan Speed	Airflow (CMM)	Sound Pressure Level (dBA)	Sound Power Level (dBA)
		Cooling (kW)	Heating (kW)				
AC052RN4DKG/EU	15.0	Max.	6.50	7.00	High	15.0	36
		Std.	5.00	6.00	Mid	14.0	33
		Min.	1.00	1.00	Low	13.0	29
AC071RN4DKG/EU	15.0	Max.	8.70	9.00	High	19.5	36
		Std.	7.10	8.00	Mid	16.5	33
		Min.	1.50	1.90	Low	14.5	29

NOTE

- Sound data is based on cooling operation.

Electric Characteristics

Model		Outdoor Unit				Input Current (Amperes)				Power Supply	
Indoor Unit	Outdoor Unit	Rated Hz	Voltage range			Outdoor Unit		Indoor Unit	Total	MCA(A)	MFA(A)
			Volts	Min.	Max.	Cooling	Heating				
AC052RN4DKG/EU	AC052RXADKG/EU	50	220 to 240	198	264	16.5	16.5	1.0	17.5	17.5	20.6
AC071RN4DKG/EU	AC071RXADKG/EU	50	220 to 240	198	264	16.5	16.5	1.0	17.5	17.5	20.6

NOTE

- MCA : Minimum circuit amperes
- MFA : Maximum fuse amperes
- Select wire size based on the value of MCA

3. Capacity Table

Wind-Free 4Way Cassette

(1) AC052RN4DKG/EU+AC052RXADKG/EU

Cooling

TC : Total Capacity, SHC : Sensible Heat Capacity, PI : Power Input

Outdoor Temperature (°C, DB)	Indoor Temperature (°C, DB / WB)																				
	20 / 14			22 / 16			25 / 18			27 / 19			28 / 20			30 / 22			32 / 24		
	TC	SHC	PI	TC	SHC	PI	TC	SHC	PI	TC	SHC	PI	TC	SHC	PI	TC	SHC	PI	TC	SHC	PI
	kW	kW	kW	kW	kW	kW	kW	kW	kW	kW	kW	kW	kW	kW	kW	kW	kW	kW	kW	kW	kW
-15	4.9	4.0	1.02	5.1	4.1	1.04	5.3	4.3	1.07	5.5	4.4	1.09	5.6	4.4	1.10	5.9	4.3	1.11	6.2	4.2	1.13
21	4.6	3.8	1.08	4.9	4.0	1.10	5.1	4.1	1.12	5.3	4.2	1.14	5.4	4.2	1.16	5.6	4.1	1.17	5.9	4.0	1.19
35	4.4	3.7	1.35	4.7	3.8	1.37	4.9	3.9	1.40	5.0	4.0	1.43	5.1	4.0	1.44	5.4	3.9	1.46	5.6	3.8	1.49
46	3.8	3.4	1.21	4.0	3.5	1.24	4.1	3.6	1.26	4.3	3.7	1.29	4.3	3.7	1.30	4.6	3.6	1.31	4.8	3.6	1.34
50	2.9	2.7	1.08	3.0	2.8	1.10	3.2	2.8	1.12	3.3	2.9	1.14	3.3	2.9	1.16	3.5	2.9	1.17	3.7	2.8	1.19

Heating

TC : Total Capacity, PI : Power Input

Outdoor Temperature (°C, DB)	Indoor Temperature (°C, DB)											
	16		18		20		21		22		24	
	TC	PI	TC	PI	TC	PI	TC	PI	TC	PI	TC	PI
	kW	kW	kW	kW	kW	kW	kW	kW	kW	kW	kW	kW
-20	4.2	1.98	4.2	1.96	4.1	1.94	4.1	1.92	4.1	1.90	4.0	1.88
-15	5.3	2.28	5.3	2.26	5.2	2.24	5.2	2.21	5.1	2.19	5.1	2.17
-5	6.0	2.13	5.9	2.11	5.9	2.09	5.8	2.07	5.8	2.04	5.7	2.02
0	6.2	1.82	6.2	1.81	6.1	1.79	6.1	1.77	6.0	1.75	5.9	1.73
7	6.1	1.52	6.1	1.50	6.0	1.49	5.9	1.48	5.9	1.46	5.8	1.45
24	8.0	1.75	7.9	1.73	7.8	1.71	7.7	1.70	7.6	1.68	7.6	1.66

NOTE

- The performance table shows the average value of each conditions.

3. Capacity Table

Wind-Free 4Way Cassette

(2) AC071RN4DKG/EU+AC071RXADKG/EU

Cooling

TC : Total Capacity, SHC : Sensible Heat Capacity, PI : Power Input

Outdoor Temperature (°C, DB)	Indoor Temperature (°C, DB / WB)																				
	20 / 14			22 / 16			25 / 18			27 / 19			28 / 20			30 / 22			32 / 24		
	TC	SHC	PI	TC	SHC	PI	TC	SHC	PI	TC	SHC	PI	TC	SHC	PI	TC	SHC	PI	TC	SHC	PI
	kW	kW	kW	kW	kW	kW	kW	kW	kW	kW	kW	kW	kW	kW	kW	kW	kW	kW	kW	kW	kW
-15	6.9	5.1	1.70	7.3	5.3	1.74	7.6	5.5	1.77	7.8	5.6	1.81	8.0	5.6	1.83	8.4	5.5	1.84	8.8	5.4	1.88
21	6.6	4.9	1.79	6.9	5.0	1.83	7.2	5.2	1.87	7.5	5.4	1.90	7.6	5.3	1.92	8.0	5.2	1.94	8.4	5.1	1.98
35	6.3	4.7	2.24	6.6	4.8	2.29	6.9	4.9	2.33	7.1	5.1	2.38	7.2	5.0	2.40	7.6	5.0	2.43	8.0	4.9	2.48
46	5.3	4.4	2.02	5.6	4.5	2.06	5.9	4.6	2.10	6.0	4.8	2.14	6.2	4.7	2.16	6.5	4.7	2.18	6.8	4.6	2.23
50	4.1	3.4	1.79	4.3	3.6	1.83	4.5	3.7	1.87	4.6	3.8	1.90	4.7	3.7	1.92	4.9	3.7	1.94	5.2	3.6	1.98

Heating

TC : Total Capacity, PI : Power Input

Outdoor Temperature (°C, DB)	Indoor Temperature (°C, DB)											
	16		18		20		21		22		24	
	TC	PI	TC	PI	TC	PI	TC	PI	TC	PI	TC	PI
	kW	kW	kW	kW	kW	kW	kW	kW	kW	kW	kW	kW
-20	5.6	3.25	5.6	3.22	5.5	3.19	5.5	3.15	5.4	3.12	5.4	3.09
-15	7.1	3.75	7.0	3.71	7.0	3.68	6.9	3.64	6.8	3.60	6.8	3.57
-5	8.0	3.50	7.9	3.46	7.8	3.43	7.8	3.40	7.7	3.36	7.6	3.33
0	8.3	3.00	8.2	2.97	8.2	2.94	8.1	2.91	8.0	2.88	7.9	2.85
7	8.2	2.50	8.1	2.47	8.0	2.45	7.9	2.43	7.8	2.40	7.8	2.38
24	10.6	2.87	10.5	2.85	10.4	2.82	10.3	2.79	10.2	2.76	10.1	2.73

NOTE

- The performance table shows the average value of each conditions.

4. Dimensional Drawing

Wind-Free 4Way Cassette

AC052/071RN4DKG/EU

Units : mm [inches]

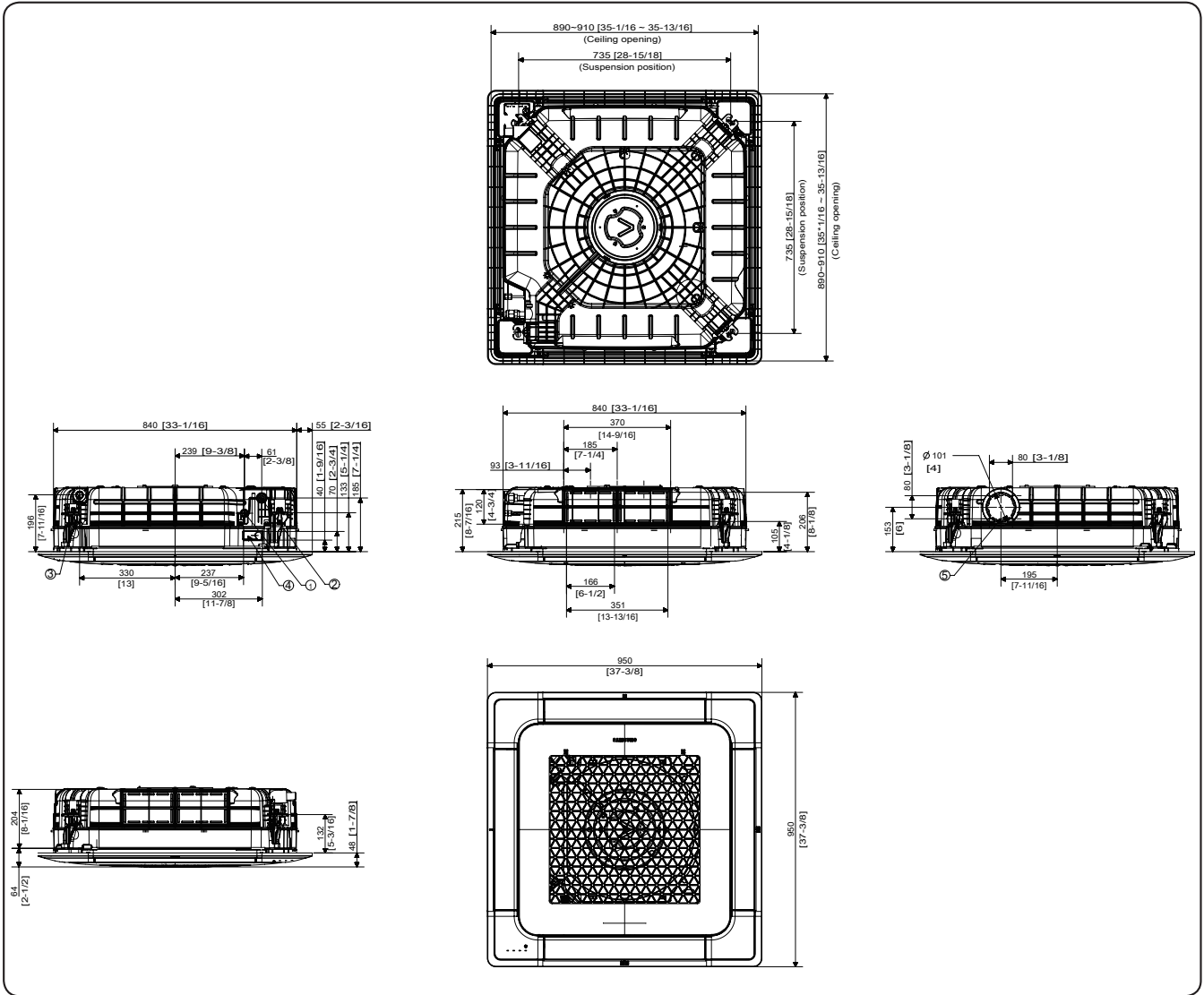

No.	Name	Description	
		AC052RN4DKG/EU	AC071RN4DKG/EU
1	Liquid pipe connection	Φ6.35(1/4)	
2	Gas pipe connection	Φ12.7(1/2)	Φ15.88(5/8)
3	Drain pipe connection	VP-25(OD32, ID25)	
4	Power supply & Communication wiring conduit		
5	Fresh air intake knockout hole	Φ10[4] , Use M4 Screw	

NOTE

- As for suspension bolt, please use M8 ~ M10.
(Procured at local site)

5. Center of Gravity

Wind-Free 4Way Cassette

AC052/071RN4DKG/EU

Units : mm [inches]

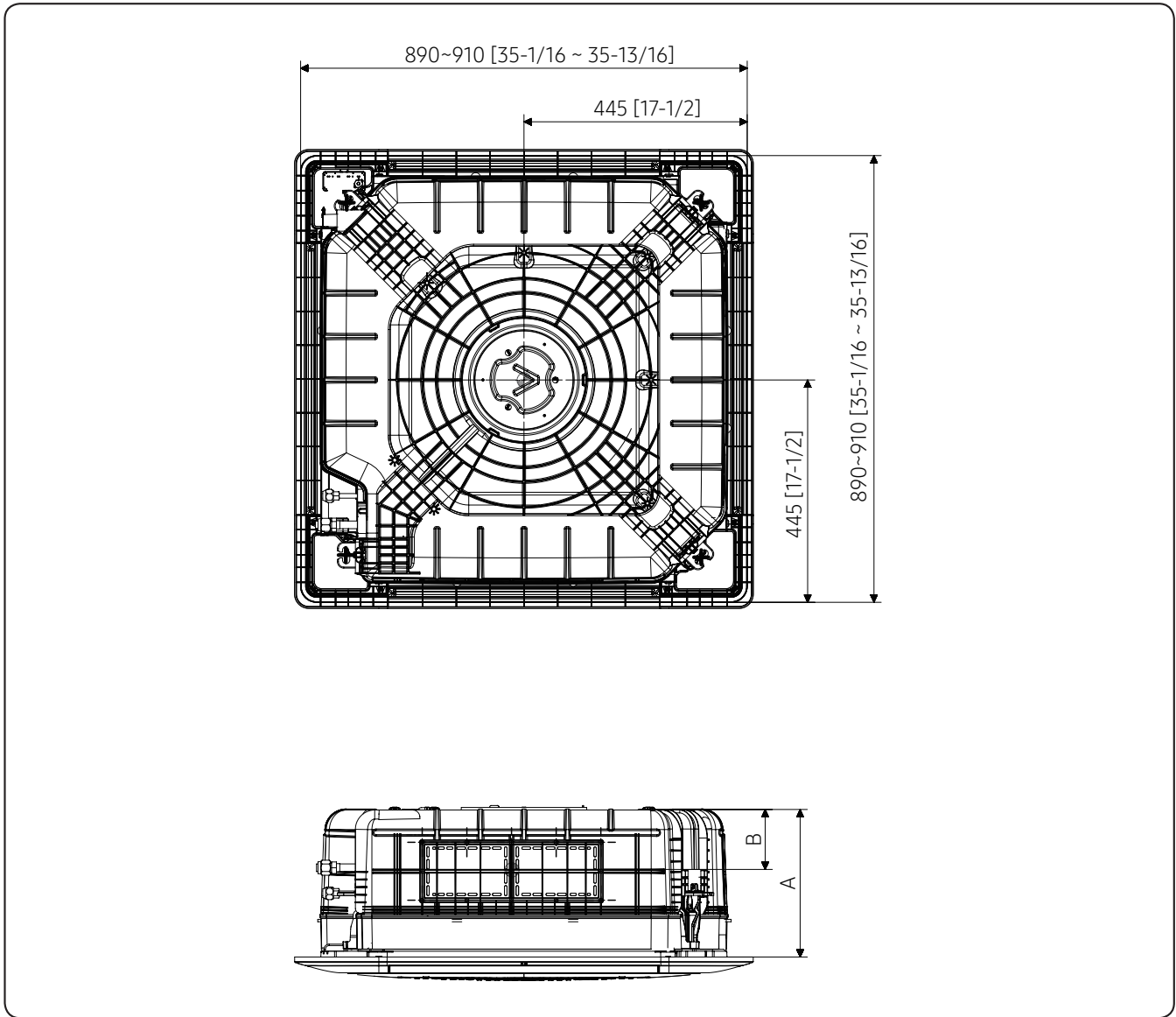

	A	B
~ 7.1kW	221 [8-11/16]	70 [2-3/4]

6. Electrical Wiring Diagram

Wind-Free 4Way Cassette

AC052/071RN4DKG/EU

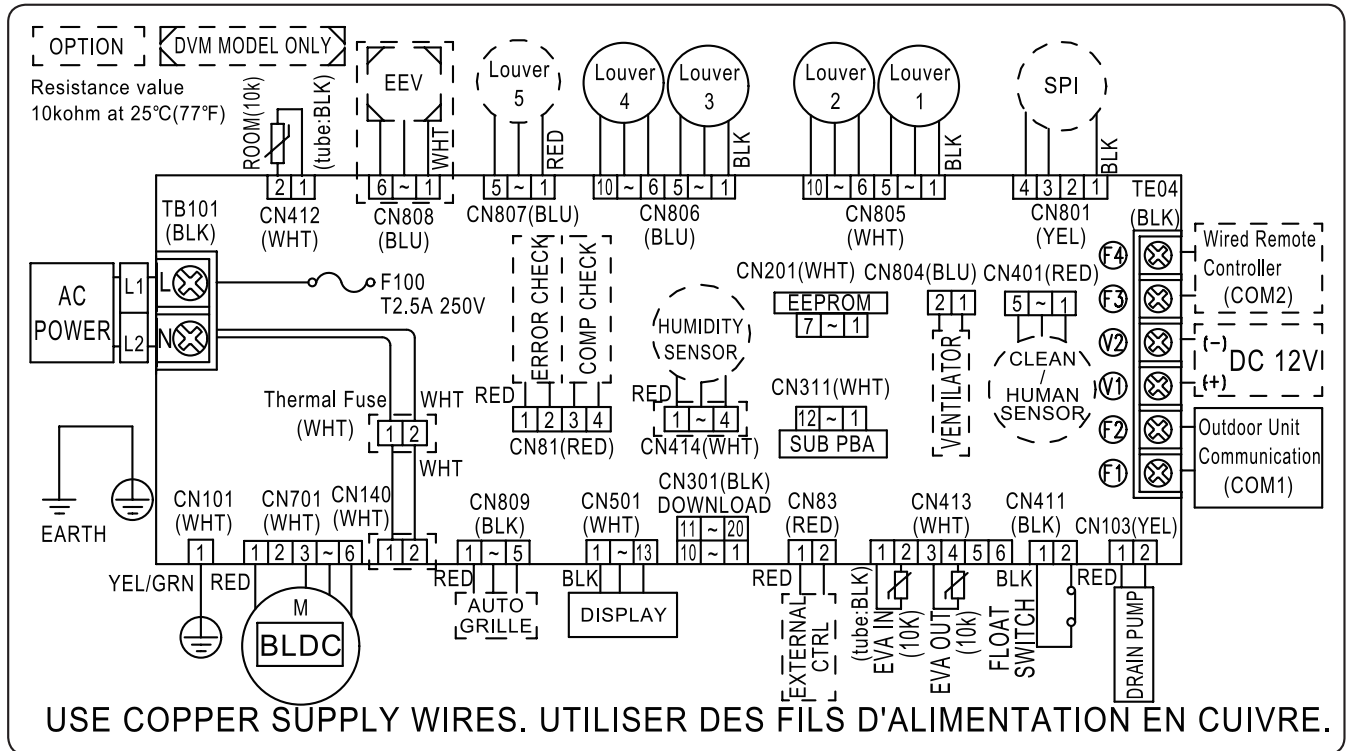

SPI	S-Plasma ion	EEV	Electronic Expansion Valve	ROOM	Thermistor ROOM in (10K)
FLOAT SWITCH	Switch of the float of Drain	EVA-IN	Thermistor EVA IN(10K)	EVA-OUT	Thermistor EVA OUT(10K)

NOTE

- This wiring diagram applies only to the Indoor unit.
- Symbols show as follow :
blk: black, red: red, blu: blue, wht: white, yel: yellow, brn: brown, sky: skyblue: grn: green
- For connection wiring indoor-outdoor transmission F1-F2, indoor-wired remote controller transmission F3-F4.
- Protective earth(screw)

7. Sound Data

Wind-Free 4Way Cassette

Sound Pressure level

Unit: dB(A)

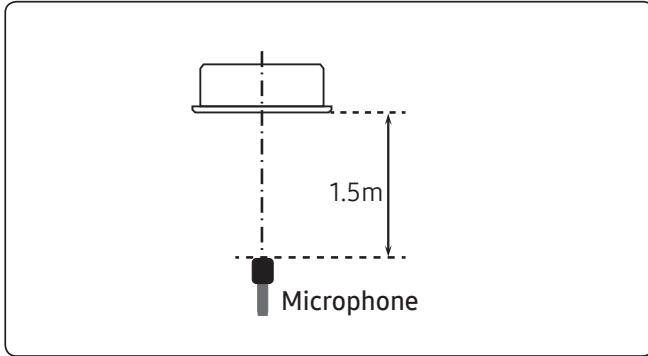

Model	HIGH	MID	LOW
AC052RN4DKG/EU	33	31	29
AC071RN4DKG/EU	36	33	29

- NR Curve

1) AC052RN4DKG/EU

2) AC071RN4DKG/EU

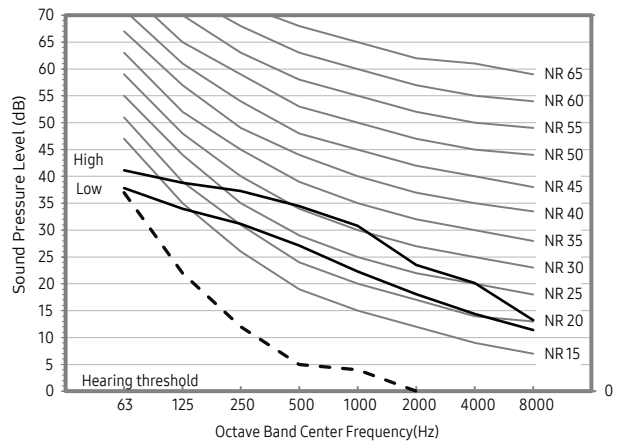
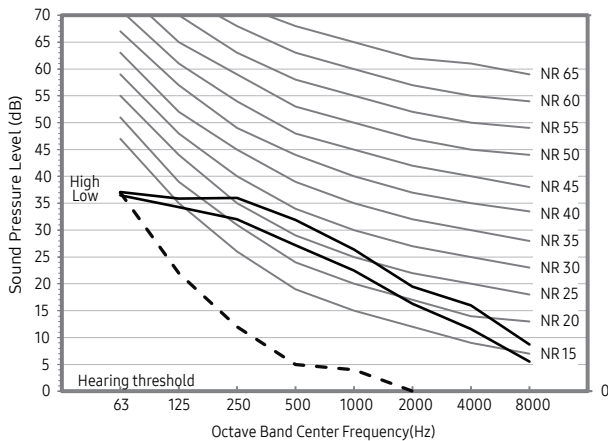

NOTE

- Specifications may be subject to change without prior notice.
 - Sound pressure level is obtained in an anechoic room.
 - Sound pressure level is a relative value, depending on the distance and acoustic environment.
 - Sound pressure level may differ depending on operation condition.
 - dB(A) = A weighted sound pressure level
 - Reference acoustic pressure 0 dB = 20μPa

7. Sound Data

Wind-Free 4Way Cassette

Sound Power level

NOTE

- Specifications may be subject to change without prior notice
 - Sound power level is an absolute value that a sound source generates.
 - dBA = A-weighted sound power level.
 - Reference power : 1pW.
 - Measured according to ISO 3741.

Unit: dB(A)

Model	Power
AC052RN4DKG/EU	49
AC071RN4DKG/EU	53

• NR Curve

1) AC052RN4DKG/EU

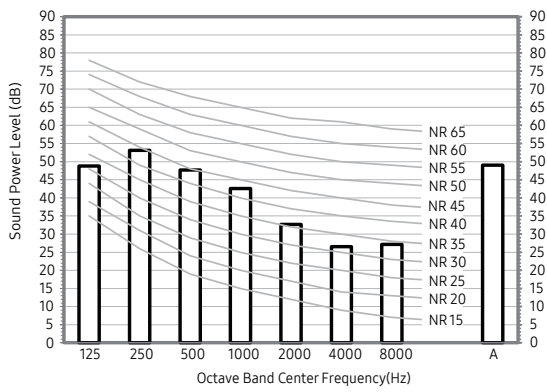

2) AC071RN4DKG/EU

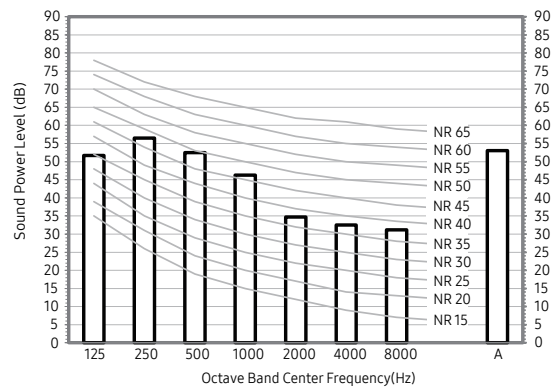

8. Temperature and air flow distribution

Wind-Free 4Way Cassette

AC052RN4DKG/EU

- Cooling Air Velocity distribution

(Discharge angle : 45 degree)

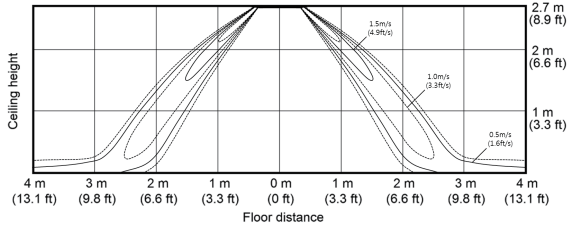

- Cooling temperature distribution

(Discharge angle : 45 degree)

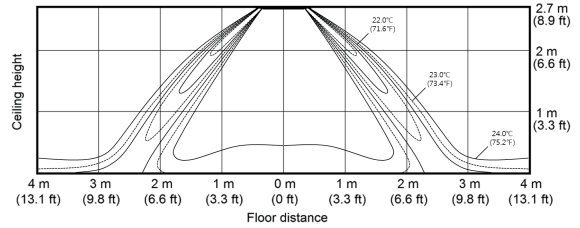

- Heating Air Velocity distribution

(Discharge angle : 52 degree)

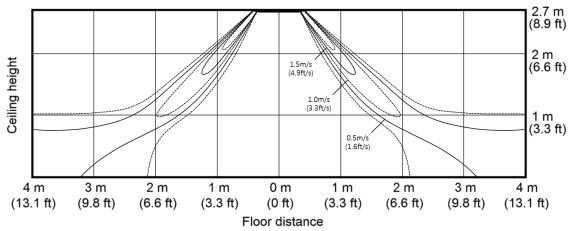

- Heating temperature distribution

(Discharge angle : 52 degree)

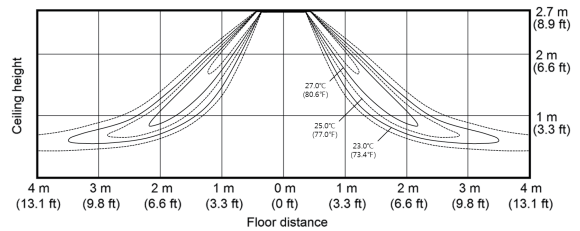

AC071RN4DKG/EU

- Cooling Air Velocity distribution

(Discharge angle : 45 degree)

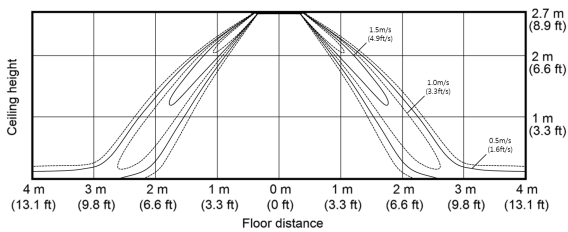

- Cooling temperature distribution

(Discharge angle : 45 degree)

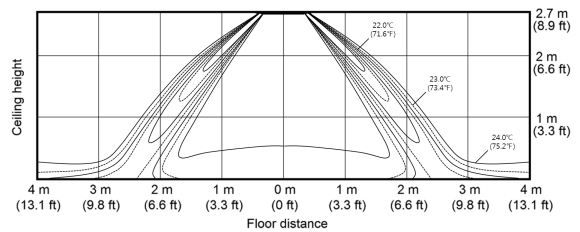

- Heating Air Velocity distribution

(Discharge angle : 52 degree)

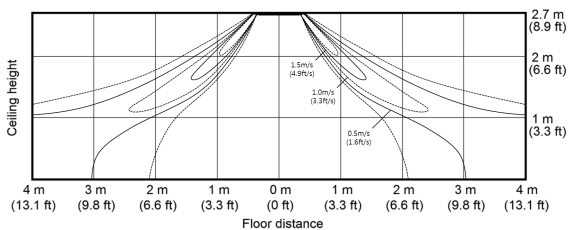

- Heating temperature distribution

(Discharge angle : 52 degree)

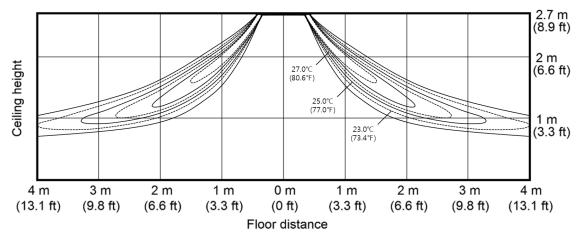

360 Cassette

1. Specification	58
2. Summary Table	61
3. Capacity Table	62
4. Dimensional Drawing	63
5. Center of Gravity	67
6. Electrical Wiring Diagram	68
7. Sound Data	69
8. Temperature and air flow distribution	71

Features & Benefits

360 Cassette

All round cooling and comfort

The Samsung 360 Cassette air conditioner offers a brand new way of staying comfortably cool in every corner of the room. Its innovative circular design not only means it perfectly fits in everywhere, adding a sophisticated look to many different sites, but it also blows cool air in all directions, so that the whole room is the same temperature*. And its bladeless outlet ensures that cool air is gently dispersed, without creating a cold draft**, and doesn't block the air flow, even at low angles, so it expels 25% more air* and spreads it farther.

EVENLY CIRCULATES & COOLS EVERY CORNER

Unlike 4-way, cassette type air conditioners that create areas of uneven airflow where cool air can't reach*, a circular outlet blows cool air in all directions, so every corner of a room is the same temperature**.

* Samsung testing compared to a general 4 way cassette type air conditioner.

** Within an 9.3m radius the temperature difference is less than 0.6°C.

Comfortably cool, not cold

A bladeless design softly disperses cool air across the room, making you comfortably cool without feeling a cold draft**. With no blades to block the air flow, it also expels 25% more air* and spreads it farther.



* Within a 5m radius, no cold draft between 0~1.5m in height (with 14.0kw).

Circular to perfectly fit in everywhere

Its innovative circular design can match a multitude of interior designs, so it perfectly fits in everywhere. Its minimalist modern styling creates a sophisticated look and its circular shape stands out beautifully.

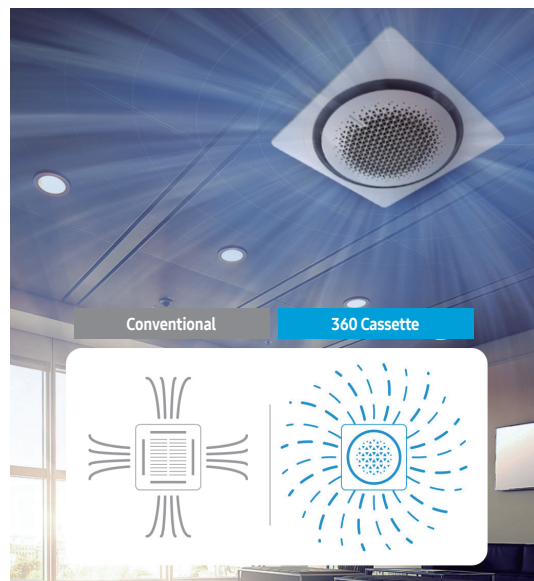
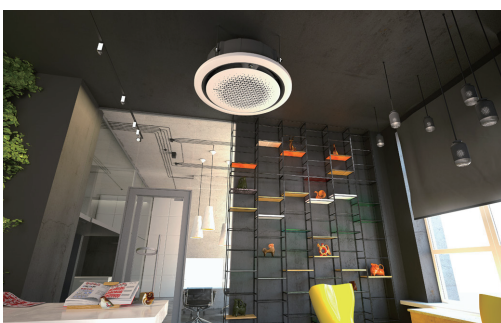

* Within an 9.3m radius the temperature difference is less than 0.6°C.

Spreads more air in more ways

An innovative Booster Fan enables cool air to be expelled at much lower angles. It creates a low pressure area around the outlet, so that cool air comes out parallel to the ceiling and disperses across a wider area.

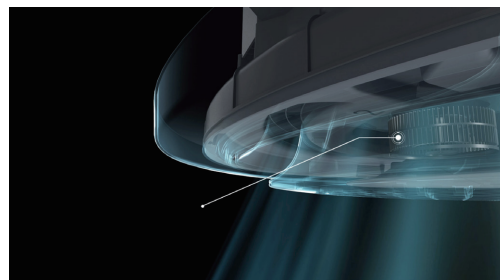

All round simpler & intuitive control

Intuitively control its performance and see where the air is going. The Wireless Remote Controller's* Jog shuttle and button offer a fun way to adjust the air flow and a Circular LED Display shows its direction.



*Optional

1. Specification

360 Cassette

System	Model Name		Indoor Unit	AC071RN4PKG/EU		
			Outdoor Unit	AC071RXADKG/EU		
	Mode			-	HEAT PUMP	
	Performance	Capacity (Min/Std/Max)	Cooling	kW	1.50 / 7.10 / 8.70	
				Btu/h	5,120 / 24,230 / 29,680	
			Heating	kW	1.90 / 8.00 / 9.00	
				Btu/h	6,480 / 27,300 / 30,710	
	Power	Power Input (Min/Std/Max)	Cooling	kW	0.35 / 2.73 / 3.60	
			Heating	kW	0.35 / 2.48 / 3.95	
		Current Input (Min/Std/Max)	Cooling	A	2.0 / 11.8 / 16.0	
			Heating	A	2.0 / 10.7 / 17.0	
		Current	MCA	A	18.0	
			MFA	A	20.6	
	Efficiency	EER	Cooling	-	2.60	
		COP	Heating	-	3.23	
		SEER (Cooling Energy Grade)		-	6.7 (A++)	
		SCOP (Heating Energy Grade)		-	4.2 (A+)	
		Pdesignh		kW	4.5	
	Piping Connections	Liquid Pipe		Type	Flare connection	
				Φ, mm (inch)	6.35 (1/4)	
		Gas Pipe		Type	Flare connection	
				Φ, mm (inch)	15.88 (5/8)	
		Heat Insulation		-	Both liquid and gas pipes	
		Piping length (ODU-IDU)	Standard	Max.	m	5
				Elevation	m	30
				Chargeless	m	15
	Min.			mm ²	0.75	
	Wiring connections	Communication	Remark	-	F1, F2	
Type			-	R32		
Refrigerant	Factory Charging		kg	1.7		
			tCO ₂ e	1.15		
Indoor Unit	Power Supply			Ø, #, V, Hz	1,2,220-240,50	
	Heat Exchanger	Type		-	F&T	
		Material	Fin	-	Al	
			Tube	-	Cu	
		Fin Treatment		-	Green Hydrophile	
	Fan	Type		-	Turbo Fan	
		Quantity		EA	1	
		Air Flow Rate	Cooling (H/M/L)	m ³ /min	17.5 / 15.9 / 14.3	
				l/s	291.6 / 265 / 238.3	
			Heating (H/M/L)	m ³ /min	17.5 / 15.9 / 14.3	
				l/s	291.6 / 265 / 238.3	
	Fan Motor	Type		-	BLDC	
Output		W x n	65			

1. Specification

360 Cassette

Indoor Unit	Model Name	Indoor Unit		AC071RN4PKG/EU	
		Outdoor Unit		AC071RXADKG/EU	
	Drain	Drain Pipe		VP-25(OD32, ID25)	
	Sound	Sound Pressure Level	High/Mid/Low/(Silent)	dB(A)	36 / 33 / 29
		Sound Power Level		dB(A)	53
	External Dimension	Net Weight		kg	20.2
		Shipping Weight		kg	24.5
		Net Dimensions (WxHxD)		mm	947 x 281 x 947
		Shipping Dimensions (WxHxD)		mm	990 x 330 x 990
	Casing	Material		HIPS	
	Panel (1)	Model Name		-	PC4NUDMAN
		Type		-	Ceiling Type(Square)
		Material		-	HIPS
		Color		-	White
		Net Weight		kg	3.6
		Shipping Weight		kg	6.3
		Net Dimensions (WxHxD)		mm	1000 x 66 x 1000
		Shipping Dimensions (WxHxD)		mm	1093 x 85 x 1083
	Panel (2)	Model Name		-	PC4NBDMAN
		Type		-	Ceiling Type(Square)
		Material		-	HIPS
		Color		-	Black
		Net Weight		kg	3.6
		Shipping Weight		kg	6.3
		Net Dimensions (WxHxD)		mm	1000 x 66 x 1000
		Shipping Dimensions (WxHxD)		mm	1093 x 85 x 1083
	Panel (3)	Model Name		-	PC4NUNMAN
		Type		-	Open Type(Circle)
		Material		-	HIPS
		Color		-	White
		Net Weight		kg	2.7
		Shipping Weight		kg	5.3
		Net Dimensions (WxHxD)		mm	1050 x 66 x 1050
		Shipping Dimensions (WxHxD)		mm	1093 x 85 x 1083
	Panel (4)	Model Name		-	PC4NBNMAN
		Type		-	Open Type(Circle)
		Material		-	HIPS
		Color		-	Black
		Net Weight		kg	2.7
		Shipping Weight		kg	5.3
Net Dimensions (WxHxD)		mm	1050 x 66 x 1050		
Shipping Dimensions (WxHxD)		mm	1093 x 85 x 1083		
Control System	Infrared remote control		-	AR-EH03E	
	Wired remote control		-	"MWR-WE13N MWR-WG00*N "	
Drain Pump	Drain Pump		-	Included	
	Max. lifting Height / Displacement		mm / Liter / h	750/24	
Additional Accessories	Drain Pump	External Model		-	
		Internal Model		-	
		Max. lifting Height / Displacement	mm / Liter / h	-	
	Air Filter		-	Removable / Washable	
	Virus Doctor		-	Option	

1. Specification

360 Cassette

Outdoor Unit	Model Name		Indoor Unit	AC071RN4PKG/EU	
			Outdoor Unit	AC071RXADKG/EU	
	Power Supply			Ø, #, V, Hz	1, 2, 220-240, 50
	Heat Exchanger	Type		-	Fin & Tube
		Material	Fin	-	Al
			Tube	-	Cu
		Fin Treatment		-	Anti-Corrosion
	Compressor	Model Name		-	UB4TN8200FE4
		Type		-	Twin BLDC
		Output		kW	1.89
		Oil	Type	-	POE
	Initial charge		cc	320	
	Fan	Type		-	Propeller
		Discharge direction		-	Front
		Quantity		EA	1
		Air Flow Rate		m ³ /min	51
	l/s			850	
	Fan Motor	Type		-	BLDC Motor
		Output		W x n	125 x 1
	Sound	Sound Pressure Level	Cooling	dB(A)	49
			Heating	dB(A)	51
		Sound Power Level		dB(A)	65
	External Dimension	Net Weight		kg	51.0
		Shipping Weight		kg	55.0
		Net Dimensions (WxHxD)		mm	880 x 798 x 310
		Shipping Dimensions (WxHxD)		mm	1,023 x 896 x 413
Casing	Material	Body	-	EGI Steel Plate	
Operating Temp. Range	Cooling		°C	-15 ~ 50	
	Heating		°C	-20 ~ 24	

NOTE

- Specification may be subject to change without prior notice.
 - 1) Performances are based on the following test conditions.
 - Cooling : Indoor temperature 27°C DB, 19°C WB, Outdoor temperature 35°C DB, 24°C WB
 - Heating : Indoor temperature 20°C DB, 15°C WB, Outdoor temperature 7°C DB, 6°C WB
 - Equivalent refrigerant pipe length 5m, Level differences 0m
 - 2) Select wire size based on the value of MCA
 - 3) Sound pressure level is obtained in an anechoic room.
 - Sound pressure level is a relative value, depending on the distance and acoustic environment.
 - Sound pressure level may differ depending on operation condition.
 - dBA = A-weighted sound pressure level
 - Reference acoustic pressure 0 dB = 20uPa
 - 4) Sound power level is an absolute value that a sound source generates.
 - dBA = A-weighted sound power level
 - Reference power : 1pW
 - Measured according to ISO 3741
 - 5) These products contain R32(GWP=675) which is fluorinated greenhouse gas.
 - 6) 'MWR-WG00*N' is new wired remote control type(Graphic).
If you need the latest control system information, please refer to SAC control TDB.

2. Summary Table

360 Cassette

Performance Characteristics

Model Code	Net Weight (kg)	Capacity		Fan Speed	Airflow (CMM)	Sound Pressure Level (dBA)	Sound Power Level (dBA)	
		Cooling (kW)	Heating (kW)					
AC071RN4PKG/EU	20.2	Max.	8.70	9.00	High	17.5	36	53
		Std.	7.10	8.00	Mid	15.9	33	
		Min.	1.50	1.90	Low	14.3	29	

NOTE

- Sound data is based on cooling operation.

Electric Characteristics

Model		Outdoor Unit				Input Current (Amperes)				Power Supply	
Indoor Unit	Outdoor Unit	Rated	Voltage range			Outdoor Unit		Indoor Unit	Total	MCA(A)	MFA(A)
		Hz	Volts	Min.	Max.	Cooling	Heating				
AC071RN4PKG/EU	AC071RXADKG/EU	50	220 to 240	198	264	16.5	16.5	1.5	18.0	18.0	20.6

NOTE

- MCA : Minimum circuit amperes
- MFA : Maximum fuse amperes
- Select wire size based on the value of MCA

3. Capacity Table

360 Cassette

(1) AC071RN4PKG/EU+AC071RXADKG/EU

Cooling

TC : Total Capacity, SHC : Sensible Heat Capacity, PI : Power Input

Outdoor Temperature (°C, DB)	Indoor Temperature (°C, DB / WB)																				
	20 / 14			22 / 16			25 / 18			27 / 19			28 / 20			30 / 22			32 / 24		
	TC	SHC	PI	TC	SHC	PI	TC	SHC	PI	TC	SHC	PI	TC	SHC	PI	TC	SHC	PI	TC	SHC	PI
	kW	kW	kW	kW	kW	kW	kW	kW	kW	kW	kW	kW	kW	kW	kW	kW	kW	kW	kW	kW	kW
-15	6.9	5.1	1.95	7.3	5.3	1.99	7.6	5.5	2.03	7.8	5.6	2.07	8.0	5.6	2.10	8.4	5.5	2.12	8.8	5.4	2.16
21	6.6	4.9	2.06	6.9	5.0	2.10	7.2	5.2	2.14	7.5	5.4	2.18	7.6	5.3	2.21	8.0	5.2	2.23	8.4	5.1	2.27
35	6.3	4.7	2.57	6.6	4.8	2.62	6.9	4.9	2.68	7.1	5.1	2.73	7.2	5.0	2.76	7.6	5.0	2.78	8.0	4.9	2.84
46	5.3	4.4	2.31	5.6	4.5	2.36	5.9	4.7	2.41	6.0	4.8	2.46	6.2	4.8	2.48	6.5	4.7	2.51	6.8	4.6	2.56
50	4.1	3.5	2.06	4.3	3.6	2.10	4.5	3.7	2.14	4.6	3.8	2.18	4.7	3.8	2.21	4.9	3.8	2.23	5.2	3.7	2.27

Heating

TC : Total Capacity, PI : Power Input

Outdoor Temperature (°C, DB)	Indoor Temperature (°C, DB)											
	16		18		20		21		22		24	
	TC	PI	TC	PI	TC	PI	TC	PI	TC	PI	TC	PI
	kW	kW	kW	kW	kW	kW	kW	kW	kW	kW	kW	kW
-20	5.6	3.29	5.6	3.26	5.5	3.22	5.5	3.19	5.4	3.16	5.4	3.13
-15	7.1	3.79	7.0	3.76	7.0	3.72	6.9	3.68	6.8	3.65	6.8	3.61
-5	8.0	3.54	7.9	3.51	7.8	3.47	7.8	3.44	7.7	3.40	7.6	3.37
0	8.3	3.04	8.2	3.01	8.2	2.98	8.1	2.95	8.0	2.92	7.9	2.89
7	8.2	2.53	8.1	2.50	8.0	2.48	7.9	2.46	7.8	2.43	7.8	2.41
24	10.6	2.91	10.5	2.88	10.4	2.85	10.3	2.82	10.2	2.80	10.1	2.77

NOTE

- The performance table shows the average value of each conditions.

4. Dimensional Drawing

360 Cassette (Square)

AC071RN4PKG/EU

Units : mm [inches]

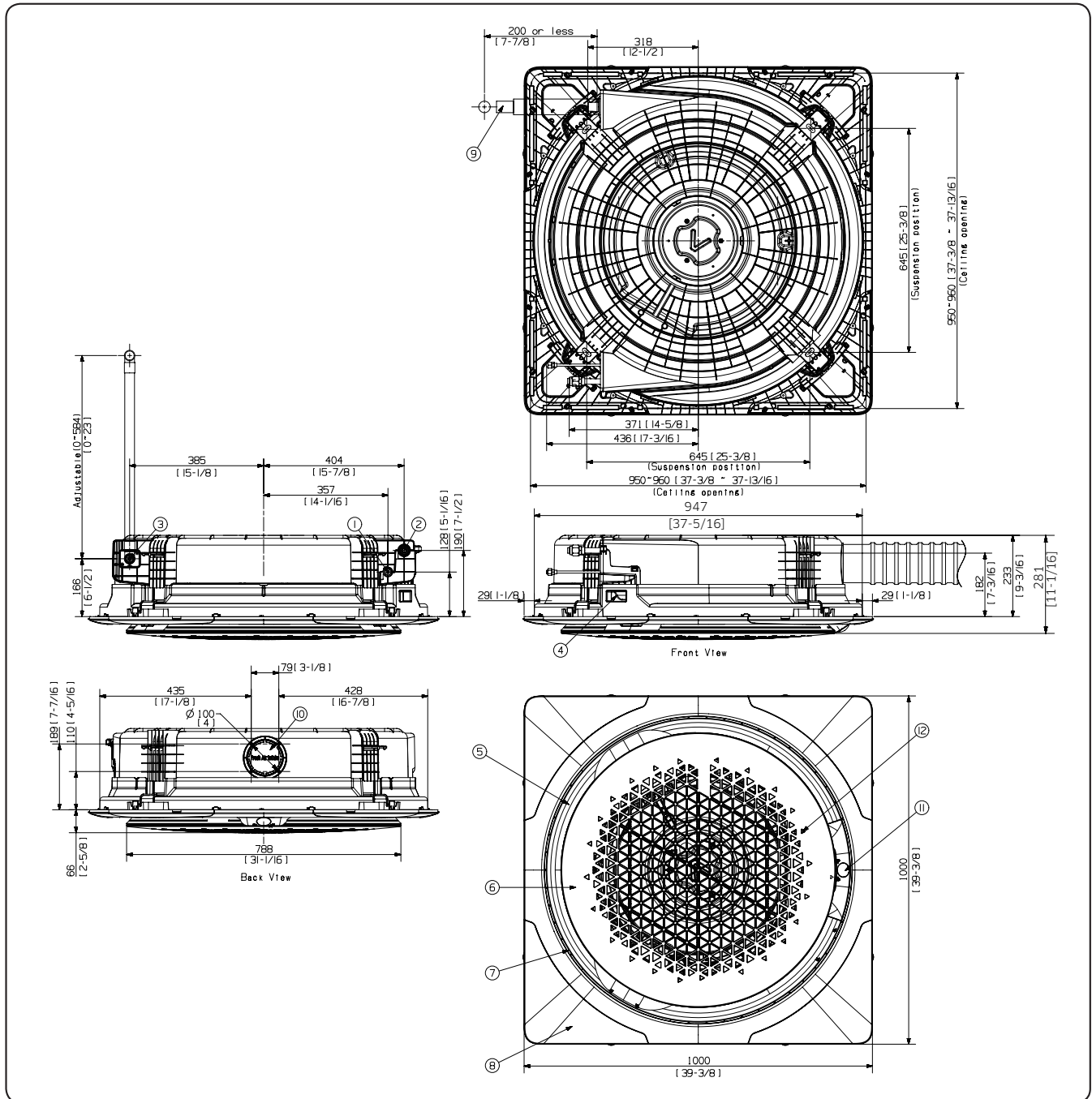

4. Dimensional Drawing

360 Cassette (Square)

No.	Name	Description	No.	Name	Description
1	Liquid pipe connection	Φ6.35(1/4)	7	Suction rim for Booster fan	
2	Gas pipe connection	Φ15.88(5/8)	8	Decoration cover	
3	Drain pipe connection	VP-25(OD32, ID25)	9	Drain hose(Accessory)	
4	Power supply & Communication wiring conduit		10	Fresh air intake knockout hole	Use M4 Screw
5	Air Discharge opening		11	Display window	
6	Air suction grille		12	Remote controller receiver	

NOTE

- As for suspension bolt, please use M8 ~ M10. (Procured at local site)
- Make sure the spacing between the ceiling and the cassette is no more than 29mm[1-1/4].
Max ceiling opening : 960mm[36-13/16].
- When the condition exceed 30°C and RH 80% in the ceiling or fresh air is inducted into the ceiling, and additional insulation is required (polyethylene foam , thickness 10mm[3/8] or more)

4. Dimensional Drawing

360 Cassette (Circle)

AC071RN4PKG/EU

Units : mm [inches]

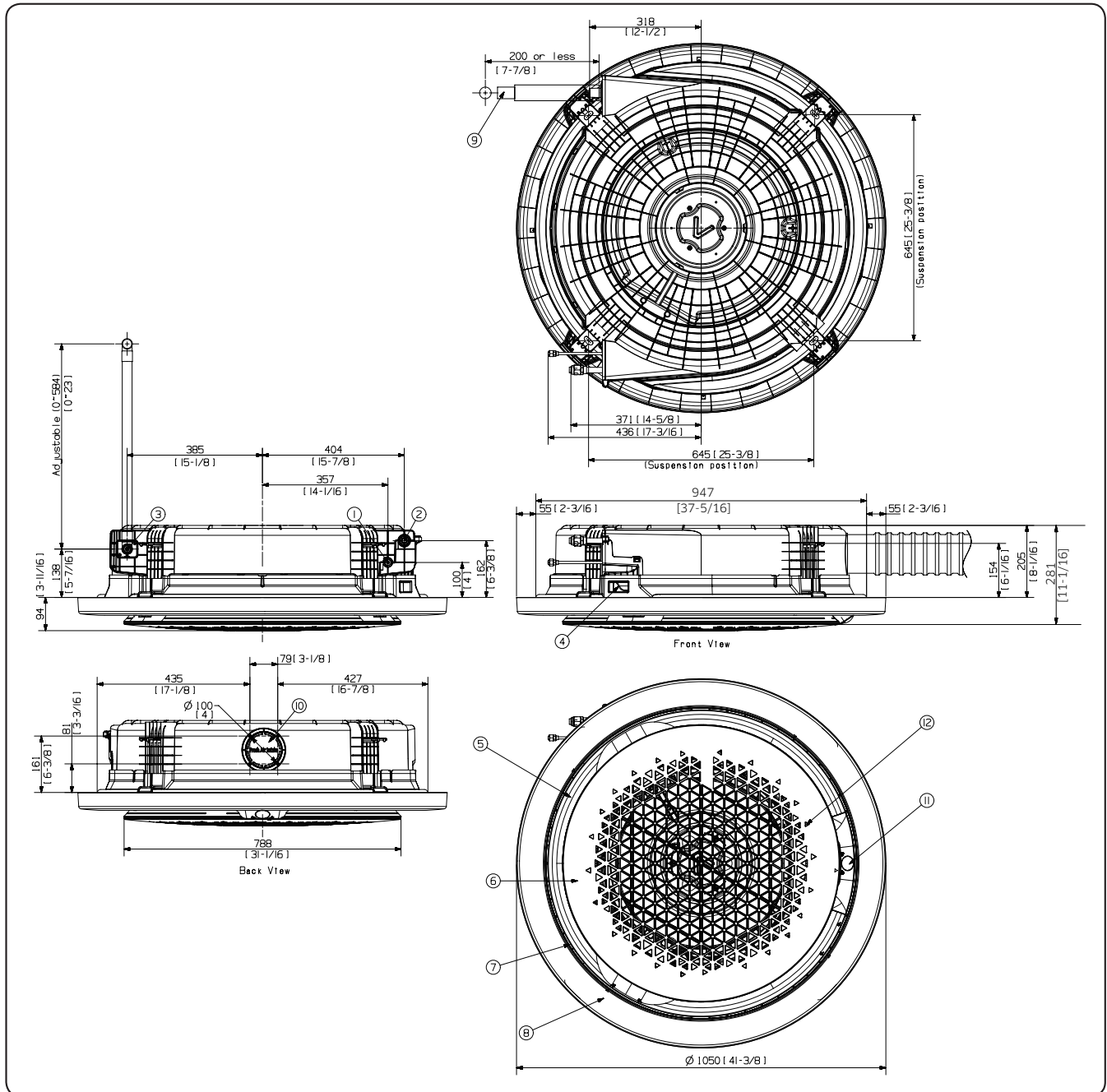

4. Dimensional Drawing

360 Cassette (Circle)

No.	Name	Description	No.	Name	Description
1	Liquid pipe connection	Φ6.35(1/4)	7	Suction rim for Booster fan	
2	Gas pipe connection	Φ15.88(5/8)	8	Decoration cover	
3	Drain pipe connection	VP-25(OD32, ID25)	9	Drain hose(Accessory)	
4	Power supply & Communication wiring conduit		10	Fresh air intake knockout hole	Use M4 Screw
5	Air Discharge opening		11	Display window	
6	Air suction grille		12	Remote controller receiver	

NOTE

- As for suspension bolt, please use M8 ~ M10. (Procured at local site)
- Make sure the spacing between the ceiling and the cassette is no more than 29mm[1-1/4].
Max ceiling opening : 960mm[36-13/16].
- When the condition exceed 30°C and RH 80% in the ceiling or fresh air is inducted into the ceiling, and additional insulation is required (polyethylene foam , thickness 10mm[3/8] or more)
- The circular panel is by default available in exposed installation.
Make inspection holes on the ceiling for easier installation and maintenance, as shown in the following table. (The size of an inspection hole must be at least 450 mm x 450 mm.)
- A suspended ceiling structure can substitute for the inspection holes.

5. Center of Gravity

360 Cassette

AC071RN4PKG/EU

Units : mm [inches]

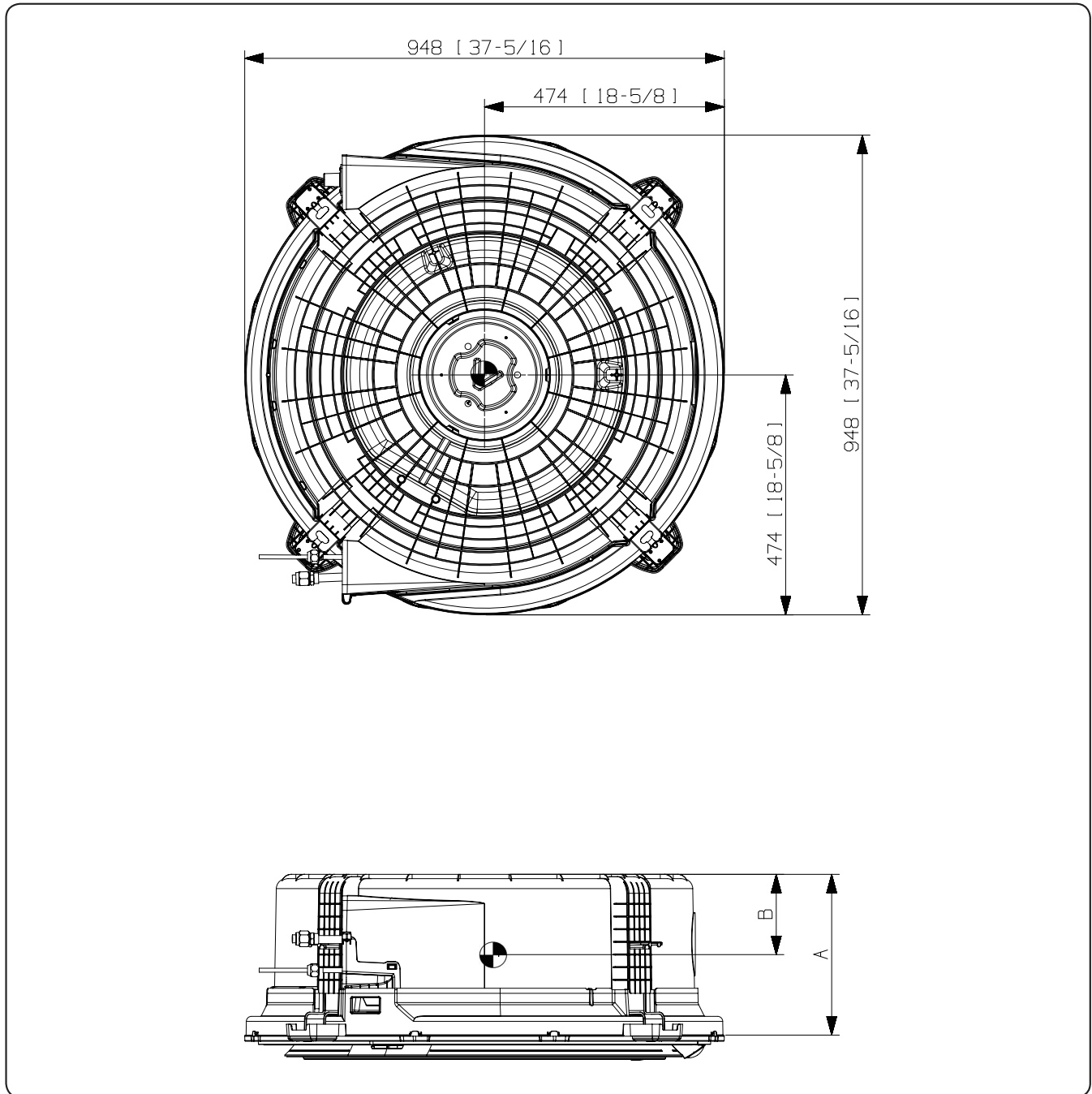

	A	B
71kW	233 [9-3/16]	165 [6-1/2]

6. Electrical Wiring Diagram

360 Cassette

AC071RN4PKG/EU

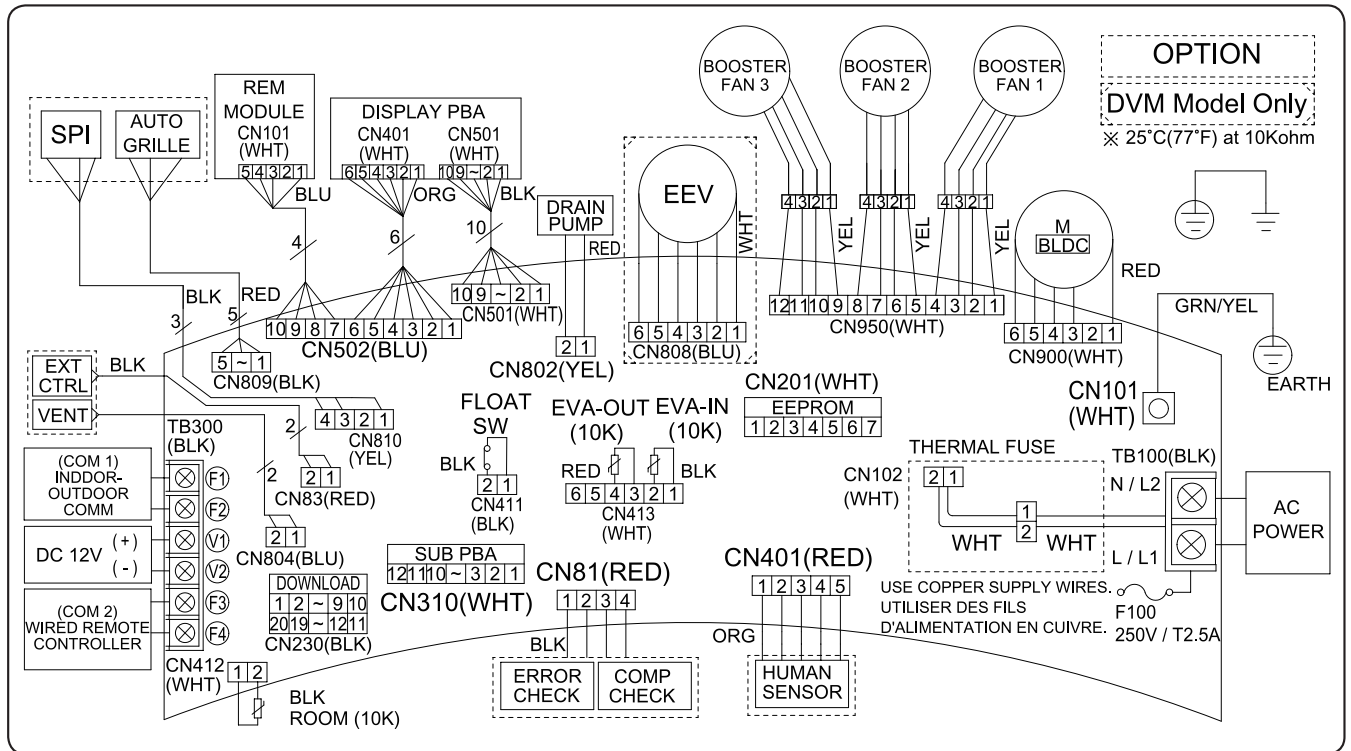

SPI	S-Plasma ion	EEV	Electronic Expansion Valve	ROOM	Thermistor ROOM in (10K)
M-BLDC	BLDC Motor	EVA-IN	Thermistor EVA IN(10K)	EVA-OUT	Thermistor EVA OUT(10K)

NOTE

- This wiring diagram applies only to the Indoor unit.
- Symbols show as follow :
blk: black, red: red, blu: blue, wht: white, yel: yellow, brn: brown, sky: skyblue: grn: green
- For connection wiring indoor-outdoor transmission F1-F2, indoor-wired remote controller transmission F3-F4.
- Protective earth(screw)

7. Sound Data

360 Cassette

Sound Pressure level

Unit: dB(A)

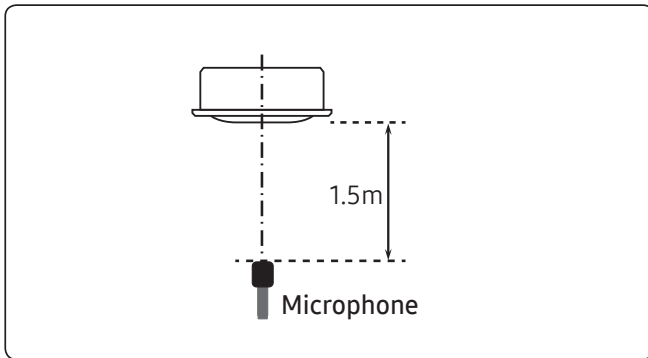

Model	HIGH	MID	LOW
AC071RN4PKG/EU	36	33	29

- NR Curve
 - 1) AC071RN4PKG/EU

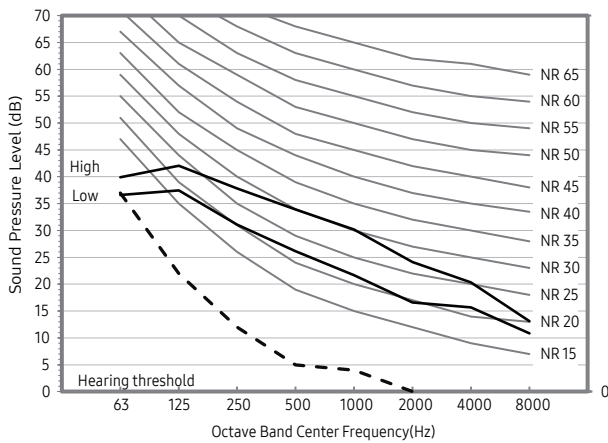

NOTE

- Specifications may be subject to change without prior notice.
 - Sound pressure level is obtained in an anechoic room.
 - Sound pressure level is a relative value, depending on the distance and acoustic environment.
 - Sound pressure level may differ depending on operation condition.
 - dBA = A weighted sound pressure level
 - Reference acoustic pressure 0 dB = 20μPa

7. Sound Data

360 Cassette

Sound Power level

NOTE

- Specifications may be subject to change without prior notice
 - Sound power level is an absolute value that a sound source generates.
 - dBA = A-weighted sound power level.
 - Reference power : 1pW.
 - Measured according to ISO 3741.

Unit: dB(A)

Model	Power
AC071RN4PKG/EU	53

- NR Curve
 - 1) AC071RN4PKG/EU

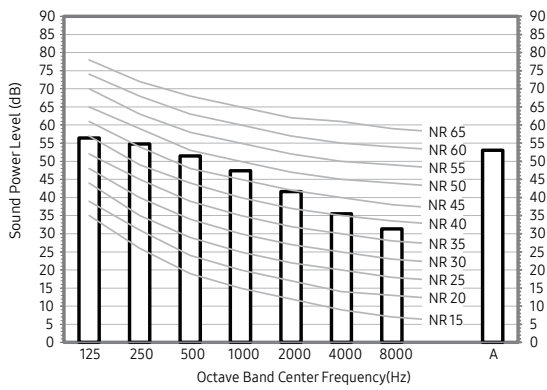

8. Temperature and air flow distribution

360 Cassette

AC071RN4PKG/EU

- Cooling Air Velocity distribution

(Discharge angle : 60 degree)

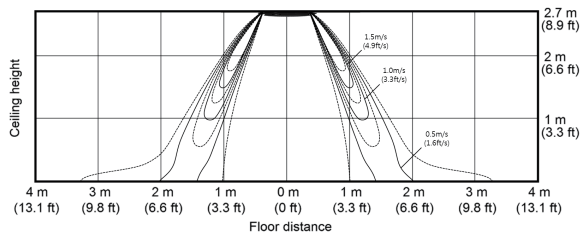

- Cooling temperature distribution

(Discharge angle : 60 degree)

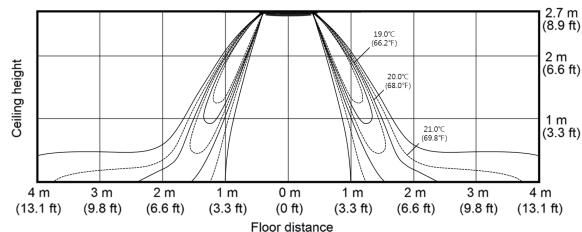

- Heating Air Velocity distribution

(Discharge angle : 60 degree)

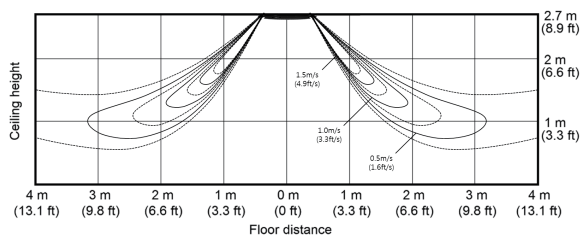

- Heating temperature distribution

(Discharge angle : 60 degree)

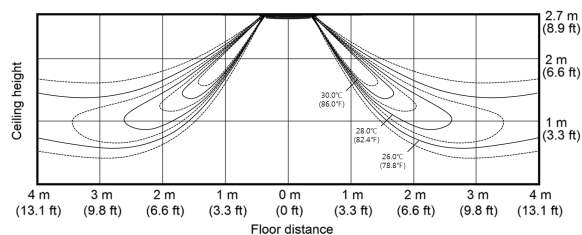

LSP Duct

1. Specification	75
2. Summary Table	81
3. Capacity Table	82
4. Dimensional Drawing	86
5. Center of Gravity	88
6. Electrical Wiring Diagram	90
7. Sound Data	91
8. Fan Characteristics	93

Features & Benefits

Slim Duct - Ultra-light, adaptable design

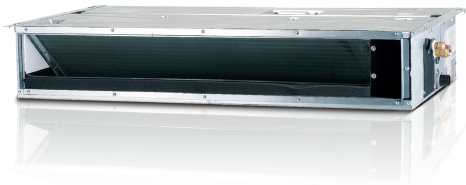

Temper any environment with industry-best lightweight design and optimized airflow

The new Samsung Slim Duct visually blends into the ceiling while providing powerful cool and warm airflow. It's also easy to install and maintain in any interior regardless of the surrounding environment with its compact size and weight—the lightest in the industry.

Flexible setup

The air inlet can be set up either on the bottom or rear of the unit, giving users greater flexibility in installation.

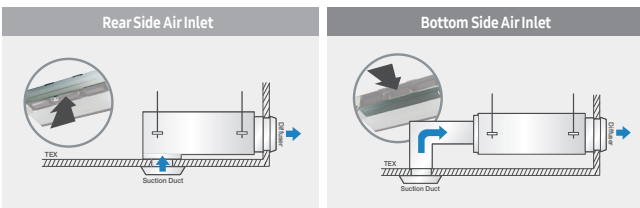

Simple drain pump installation

The new drain pump in the Slim Duct unit can be installed from the side by simply removing the right side panel. Users no longer need to disassemble the top cover to install, check or repair the drain pump for maximum convenience.

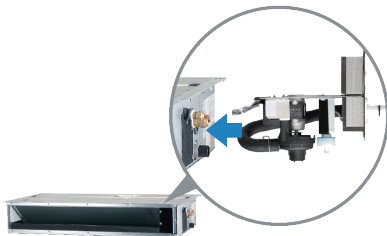

Various installation options

Slim Duct S adopts an ultra-compact, slim size with its thin width, which is 200 mm narrower than conventional products. This slender build enables flexible installation and maintenance in various environments.

World's lightest weight

The efficient Slim Duct S is the lightest duct air conditioning unit on the market. At a weight that's 15 percent lighter than conventional units, Slim Duct S offers the best in convenient installation and maintenance.

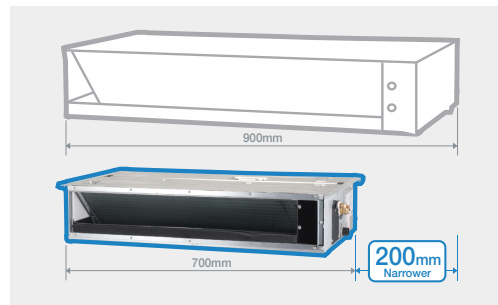

Easy access, easy maintenance

Slim Duct features a flexible design that enables users to easily access its parts to maintain the unit.

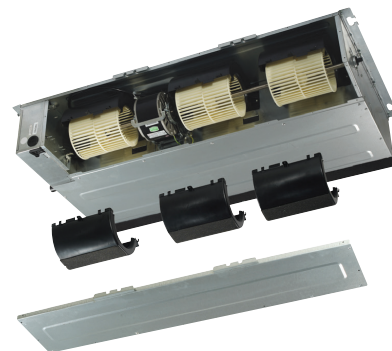

Features & Benefits

Duct S

Overview

Samsung Ducted Type air conditioning units are a smart solution for low-maintenance, consistent cooling and heating performance in any environment. Their compact, slim frame blends seamlessly into ceilings, enhancing the beauty of the interior space and affording users more flexible installation options. Offering a comprehensive lineup, Samsung Ducted Type air conditioning units offer just the right solution for every need--from the office or shop to the restaurant kitchen.

Experience performance and convenient comfort for any weather condition

Samsung Duct S delivers unparalleled cooling and heating and flexible management with customizable comfort settings in any climate—all year round. Plus, it boasts a slim, compact size and multiple access points for easy setup exactly where needed.



Smart pressure control

Samsung Ducted Type units feature a smart pressure control system. This system adjusts the fan speed based on the external static pressure (ESP), delivering consistent cooling and heating power, regardless of the surrounding environment.

Convenient installation

The optional lift-up drain pump lifts condensed water up to 750 mm, compared to a limit of 700 mm on conventional models, for flexible and convenient installation.

The Duct S indoor air conditioning unit delivers smooth, consistent operation and convenience with features such as:

- Efficient operation. Stage the desired atmosphere with energy-efficient performance and customized airflow.
- Smart management. Cool spaces efficiently and manage the air conditioning unit even while away, with features designed for efficiency and control.
- Easy, flexible setup. Install and maintain even multiple units with a compact and easily accessible design.

1. Specification

LSP Duct

Model Name	Indoor Unit			AC026RNLDKG/EU	AC035RNLDKG/EU
	Outdoor Unit			AC026RXADKG/EU	AC035RXADKG/EU
Mode				-	HEAT PUMP
Performance	Capacity (Min/Std/Max)	Cooling	kW	0.80 / 2.60 / 3.80	0.85 / 3.50 / 4.30
			Btu/h	2,730 / 8,870 / 12,970	2,900 / 11,940 / 14,670
		Heating	kW	0.98 / 3.30 / 4.30	1.00 / 4.00 / 5.00
			Btu/h	3,340 / 11,260 / 14,670	3,410 / 13,650 / 17,060
Power	Power Input (Min/Std/Max)	Cooling	kW	0.19 / 0.68 / 1.20	0.20 / 1.12 / 1.40
		Heating	kW	0.20 / 0.87 / 1.45	0.19 / 1.21 / 1.80
	Current Input (Min/Std/Max)	Cooling	A	1.5 / 3.6 / 5.5	1.6 / 5.4 / 6.5
		Heating	A	1.3 / 4.5 / 7.0	1.3 / 5.8 / 10.5
	Current	MCA	A	11.7	11.7
		MFA	A	12.9	12.9
Efficiency	EER	Cooling	-	3.82	3.12
	COP	Heating	-	3.79	3.31
	SEER (Cooling Energy Grade)		-	6.2 (A++)	6.1 (A++)
	SCOP (Heating Energy Grade)		-	4.0 (A+)	4.0 (A+)
	Pdesignh		kW	2.0	2.0
Piping Connections	Liquid Pipe	Type		Flare connection	Flare connection
		Φ, mm (inch)		6.35 (1/4)	6.35 (1/4)
	Gas Pipe	Type		Flare connection	Flare connection
		Φ, mm (inch)		9.52 (3/8)	9.52 (3/8)
	Heat Insulation		-	Both liquid and gas pipes	Both liquid and gas pipes
	Piping length (ODU-IDU)	Standard	m	5	5
		Max.	m	20	20
Elevation		m	15	15	
Chargeless		m	20	20	
Wiring connections	Communication	Min.	mm ²	0.75	0.75
		Remark	-	F1, F2	F1, F2
Refrigerant	Type		-	R32	R32
	Factory Charging	kg	0.9	0.9	
		tCO ₂ e	0.61	0.61	

1. Specification

LSP Duct

Model Name	Indoor Unit		AC026RNLDKG/EU	AC035RNLDKG/EU
	Outdoor Unit		AC026RXADKG/EU	AC035RXADKG/EU
Power Supply			Ø, #, V, Hz	1,2,220-240,50
Heat Exchanger	Type		-	F&T
	Material	Fin	-	Al
		Tube	-	Cu
	Fin Treatment		-	Green Hydrophile
Fan	Type		-	Sirocco
	Quantity		EA	2
	Air Flow Rate	Cooling (H/M/L)	m ³ /min	9.0 / 8.2 / 7.4
			l/s	150 / 136.6 / 123.3
		Heating (H/M/L)	m ³ /min	10.0 / 9.0 / 8.0
			l/s	166.6 / 150 / 133.3
External Static Pressure	Min/Std/Max	mmAq	0/2.5/4	
		Pa	0/25/39	
Fan Motor	Type		-	BLDC
	Output		W x n	68
Drain	Drain Pipe		Φ, mm	VP-25(OD32, ID25)
Sound	Sound Pressure Level	High/Mid/Low/(Silent)	dB(A)	32 / 29 / 26
	Sound Power Level		dB(A)	53
External Dimension	Net Weight		kg	19.0
	Shipping Weight		kg	23.0
	Net Dimensions (WxHxD)		mm	700 x 199 x 600
	Shipping Dimensions (WxHxD)		mm	951 x 280 x 709
Casing	Material		-	EGI Steel Plate
	Infrared remote control		-	AR-EH03E
Control System	Wired remote control		-	MWR-WE13N MWR-WG00*N
	Drain Pump	Drain Pump		-
Max. lifting Height / Displacement		mm / Liter / h	-	
Additional Accessories	Drain Pump	External Model	-	-
		Internal Model	-	MDP-E075SEE3D
		Max. lifting Height / Displacement	mm / Liter / h	750/24
	Air Filter		-	Removable / Washable
	Virus Doctor		-	-

1. Specification

LSP Duct

	Model Name			AC026RNLDKG/EU	AC035RNLDKG/EU	
	Indoor Unit			AC026RXADKG/EU	AC035RXADKG/EU	
Outdoor Unit	Power Supply		Ø, #, V, Hz	1, 2, 220-240, 50	1, 2, 220-240, 50	
	Heat Exchanger	Type		-	Fin & Tube	Fin & Tube
		Material	Fin	-	Al	Al
			Tube	-	Cu	Cu
	Fin Treatment		-	Anti-Corrosion	Anti-Corrosion	
	Compressor	Model Name			UB9AK5090FER	UB9AK5090FER
		Type		-	Single BLDC	Single BLDC
		Output		kW	0.86	0.86
		Oil	Type	-	POE	POE
	Initial charge		cc	320	320	
	Fan	Type		-	Propeller	Propeller
		Discharge direction		-	Front	Front
		Quantity		EA	1	1
		Air Flow Rate			m ³ /min	29
			l/s	483	500	
	Fan Motor	Type		-	BLDC Motor	BLDC Motor
		Output		W x n	40 x 1	40 x 1
	Sound	Sound Pressure Level	Cooling	dB(A)	46	48
			Heating	dB(A)	47	48
		Sound Power Level		dB(A)	59	61
External Dimension	Net Weight		kg	32.5	32.5	
	Shipping Weight		kg	35.5	35.5	
	Net Dimensions (WxHxD)		mm	790 x 548 x 285	790 x 548 x 285	
	Shipping Dimensions (WxHxD)		mm	913 x 622 x 371	913 x 622 x 371	
Casing	Material	Body	-	EGI Steel Plate	EGI Steel Plate	
	Operating Temp. Range	Cooling	°C	-15 ~ 46	-15 ~ 46	
Heating		°C	-20 ~ 24	-20 ~ 24		

NOTE

- Specification may be subject to change without prior notice.
 - 1) Performances are based on the following test conditions.
 - Cooling : Indoor temperature 27°C DB, 19°C WB, Outdoor temperature 35°C DB, 24°C WB
 - Heating : Indoor temperature 20°C DB, 15°C WB, Outdoor temperature 7°C DB, 6°C WB
 - Equivalent refrigerant pipe length 5m, Level differences 0m
 - 2) Select wire size based on the value of MCA
 - 3) Sound pressure level is obtained in an anechoic room.
 - Sound pressure level is a relative value, depending on the distance and acoustic environment.
 - Sound pressure level may differ depending on operation condition.
 - dBA = A-weighted sound pressure level
 - Reference acoustic pressure 0 dB = 20uPa
 - 4) Sound power level is an absolute value that a sound source generates.
 - dBA = A-weighted sound power level
 - Reference power : 1pW
 - Measured according to ISO 3741
 - 5) These products contain R32(GWP=675) which is fluorinated greenhouse gas.
 - 6) 'MWR-WG00*N' is new wired remote control type(Graphic).
If you need the latest control system information, please refer to SAC control TDB.

1. Specification

LSP Duct

Model Name	Indoor Unit			AC052RNLDKG/EU	AC071RNLDKG/EU
	Outdoor Unit			AC052RXADKG/EU	AC071RXADKG/EU
Mode				-	HEAT PUMP
Performance	Capacity (Min/Std/Max)	Cooling	kW	1.20 / 5.00 / 6.50	1.50 / 7.10 / 8.70
			Btu/h	4,100 / 17,060 / 22,180	5,120 / 24,230 / 29,690
		Heating	kW	1.10 / 6.00 / 7.20	1.90 / 8.00 / 9.00
			Btu/h	3,750 / 20,470 / 24,570	6,480 / 27,300 / 30,710
Power	Power Input (Min/Std/Max)	Cooling	kW	0.35 / 1.69 / 2.20	0.35 / 2.38 / 3.60
		Heating	kW	0.26 / 1.74 / 2.70	0.35 / 2.38 / 3.95
	Current Input (Min/Std/Max)	Cooling	A	2.1 / 7.7 / 10.0	2.0 / 10.5 / 16.0
		Heating	A	1.7 / 7.8 / 12.0	2.0 / 10.4 / 17.0
	Current	MCA	A	18.2	18.2
		MFA	A	20.6	20.6
Efficiency	EER	Cooling	-	2.96	2.98
	COP	Heating	-	3.45	3.36
	SEER (Cooling Energy Grade)		-	6.1 (A++)	6.0 (A+)
	SCOP (Heating Energy Grade)		-	3.9 (A)	3.9 (A)
	Pdesignh		kW	2.4	3.7
Piping Connections	Liquid Pipe	Type		Flare connection	Flare connection
		Φ, mm (inch)		6.35 (1/4)	6.35 (1/4)
	Gas Pipe	Type		Flare connection	Flare connection
		Φ, mm (inch)		12.7 (1/2)	15.88 (5/8)
	Heat Insulation		-	Both liquid and gas pipes	Both liquid and gas pipes
	Piping length (ODU-IDU)	Standard	m	5	5
		Max.	m	30	50
Elevation		m	20	30	
Chargeless		m	10	15	
Wiring connections	Communication	Min.	mm ²	0.75	0.75
		Remark	-	F1, F2	F1, F2
Refrigerant	Type		-	R32	R32
	Factory Charging		kg	1.2	1.7
			tCO ₂ e	0.81	1.15

1. Specification

LSP Duct

Indoor Unit	Model Name		Indoor Unit	AC052RNLDKG/EU	AC071RNLDKG/EU
			Outdoor Unit	AC052RXADKG/EU	AC071RXADKG/EU
	Power Supply		Ø, #, V, Hz	1,2,220-240,50	1,2,220-240,50
Heat Exchanger	Type		-	F&T	F&T
	Material	Fin	-	Al	Al
		Tube	-	Cu	Cu
Fin Treatment		-	Green Hydrophile	Green Hydrophile	
Fan	Type		-	Sirocco	Sirocco
	Quantity		EA	3	3
	Air Flow Rate	Cooling (H/M/L)	m ³ /min	13.5 / 11.5 / 9.5	19.0 / 14.5 / 10.0
		Heating (H/M/L)	l/s	225 / 191.6 / 158.3	316.6 / 241.6 / 166.6
	External Static Pressure	Min/Std/Max	m ³ /min	16.0 / 14.0 / 12.0	19.0 / 14.5 / 10.0
			l/s	266.6 / 233.3 / 200	316.6 / 241.6 / 166.6
Fan Motor	Type		-	BLDC	BLDC
	Output		W x n	153	153
Drain	Drain Pipe		Φ, mm	VP-25(OD32, ID25)	VP-25(OD32, ID25)
Sound	Sound Pressure Level	High/Mid/Low/(Silent)	dB(A)	33 / 30 / 27	37 / 32 / 27
	Sound Power Level		dB(A)	55	59
External Dimension	Net Weight		kg	23.5	23.5
	Shipping Weight		kg	27.0	27.0
	Net Dimensions (WxHxD)		mm	1,100 x 200 x 450	1,100 x 200 x 450
	Shipping Dimensions (WxHxD)		mm	1,319 x 270 x 529	1,319 x 270 x 529
Casing	Material		-	EGI Steel Plate	EGI Steel Plate
Control System	Infrared remote control		-	AR-EH03E	AR-EH03E
	Wired remote control		-	MWR-WE13N MWR-WG00*N	MWR-WE13N MWR-WG00*N
Drain Pump	Drain Pump		-	-	-
	Max. lifting Height / Displacement		mm / Liter / h	-	-
Additional Accessories	Drain Pump	External Model	-	MDP-G075SP	MDP-G075SP
		Internal Model	-	-	-
		Max. lifting Height / Displacement	mm / Liter / h	750/24	750/24
	Air Filter		-	Removable / Washable	Removable / Washable
	Virus Doctor		-	Option	Option

1. Specification

LSP Duct

	Model Name			AC052RNLDKG/EU	AC071RNLDKG/EU	
	Indoor Unit			AC052RXADKG/EU	AC071RXADKG/EU	
Outdoor Unit	Power Supply		Ø, #, V, Hz	1, 2, 220-240, 50	1, 2, 220-240, 50	
	Heat Exchanger	Type		-	Fin & Tube	Fin & Tube
		Material	Fin	-	Al	Al
			Tube	-	Cu	Cu
	Fin Treatment		-	Anti-Corrosion	Anti-Corrosion	
	Compressor	Model Name			UB9TK3150FE4	UB4TN8200FE4
		Type		-	Twin BLDC	Twin BLDC
		Output		kW	1.51	1.89
		Oil	Type	-	POE	POE
	Initial charge		cc	320	320	
	Fan	Type		-	Propeller	Propeller
		Discharge direction		-	Front	Front
		Quantity		EA	1	1
		Air Flow Rate			m ³ /min	40
			l/s	667	850	
	Fan Motor	Type		-	BLDC Motor	BLDC Motor
		Output		W x n	125 x 1	125 x 1
	Sound	Sound Pressure Level	Cooling	dB(A)	48	49
			Heating	dB(A)	48	51
		Sound Power Level		dB(A)	62	65
External Dimension	Net Weight		kg	43.5	51.0	
	Shipping Weight		kg	46.5	55.0	
	Net Dimensions (WxHxD)		mm	880 x 638 x 310	880 x 798 x 310	
	Shipping Dimensions (WxHxD)		mm	1,023 x 742 x 413	1,023 x 896 x 413	
Casing	Material	Body	-	EGL Steel Plate	EGL Steel Plate	
		Operating Temp. Range		°C	-15 ~ 50	-15 ~ 50
		Heating	°C	-20 ~ 24	-20 ~ 24	

NOTE

- Specification may be subject to change without prior notice.
 - 1) Performances are based on the following test conditions.
 - Cooling : Indoor temperature 27°C DB, 19°C WB, Outdoor temperature 35°C DB, 24°C WB
 - Heating : Indoor temperature 20°C DB, 15°C WB, Outdoor temperature 7°C DB, 6°C WB
 - Equivalent refrigerant pipe length 5m, Level differences 0m
 - 2) Select wire size based on the value of MCA
 - 3) Sound pressure level is obtained in an anechoic room.
 - Sound pressure level is a relative value, depending on the distance and acoustic environment.
 - Sound pressure level may differ depending on operation condition.
 - dBA = A-weighted sound pressure level
 - Reference acoustic pressure 0 dB = 20uPa
 - 4) Sound power level is an absolute value that a sound source generates.
 - dBA = A-weighted sound power level
 - Reference power : 1pW
 - Measured according to ISO 3741
 - 5) These products contain R32(GWP=675) which is fluorinated greenhouse gas.
 - 6) 'MWR-WG00*N' is new wired remote control type(Graphic).
If you need the latest control system information, please refer to SAC control TDB.

2. Summary Table

LSP Duct

Performance Characteristics

Model Code	Net Weight (kg)	Capacity		Fan Speed	Airflow (CMM)	Sound Pressure Level (dBA)	Sound Power Level (dBA)	
		Cooling (kW)	Heating (kW)					
AC026RNLDKG/EU	19.4	Max.	3.80	4.30	High	9.0	32	53
		Std.	2.60	3.30	Mid	8.2	29	
		Min.	0.80	0.98	Low	7.4	26	
AC035RNLDKG/EU	19.4	Max.	4.30	5.00	High	9.5	33	53
		Std.	3.50	4.00	Mid	8.5	30	
		Min.	0.85	1.00	Low	7.5	27	
AC052RNLDKG/EU	23.4	Max.	6.50	7.20	High	13.5	33	55
		Std.	5.00	6.00	Mid	11.5	30	
		Min.	1.20	1.10	Low	9.5	27	
AC071RNLDKG/EU	23.4	Max.	8.70	9.00	High	19.0	37	59
		Std.	7.10	8.00	Mid	14.5	32	
		Min.	1.50	1.90	Low	10.0	27	

NOTE

- Sound data is based on cooling operation.

Electric Characteristics

Model		Outdoor Unit				Input Current (Amperes)				Power Supply	
Indoor Unit	Outdoor Unit	Rated	Voltage range			Outdoor Unit		Indoor Unit	Total	MCA(A)	MFA(A)
		Hz	Volts	Min.	Max.	Cooling	Heating				
AC026RNLDKG/EU	AC026RXADKG/EU	50	220 to 240	198	264	10	10	1.7	11.7	11.7	12.9
AC035RNLDKG/EU	AC035RXADKG/EU	50	220 to 240	198	264	10	10	1.7	11.7	11.7	12.9
AC052RNLDKG/EU	AC052RXADKG/EU	50	220 to 240	198	264	16.5	16.5	1.7	18.2	18.2	20.6
AC071RNLDKG/EU	AC071RXADKG/EU	50	220 to 240	198	264	16.5	16.5	1.7	18.2	18.2	20.6

NOTE

- MCA : Minimum circuit amperes
- MFA : Maximum fuse amperes
- Select wire size based on the value of MCA

3. Capacity Table

LSP Duct

(1) AC026RNLDKG/EU+AC026RXADKG/EU

Cooling

TC : Total Capacity, SHC : Sensible Heat Capacity, PI : Power Input

Outdoor Temperature (°C, DB)	Indoor Temperature (°C, DB / WB)																				
	20 / 14			22 / 16			25 / 18			27 / 19			28 / 20			30 / 22			32 / 24		
	TC	SHC	PI	TC	SHC	PI	TC	SHC	PI	TC	SHC	PI	TC	SHC	PI	TC	SHC	PI	TC	SHC	PI
	kW	kW	kW	kW	kW	kW	kW	kW	kW	kW	kW	kW	kW	kW	kW	kW	kW	kW	kW	kW	kW
-15	2.5	2.0	0.49	2.7	2.1	0.50	2.8	2.1	0.51	2.9	2.2	0.52	2.9	2.2	0.52	3.1	2.2	0.53	3.2	2.1	0.54
21	2.4	1.9	0.51	2.5	2.0	0.52	2.6	2.0	0.53	2.7	2.1	0.54	2.8	2.1	0.55	2.9	2.1	0.55	3.1	2.0	0.57
35	2.3	1.8	0.64	2.4	1.9	0.65	2.5	1.9	0.67	2.6	2.0	0.68	2.7	2.0	0.69	2.8	2.0	0.69	2.9	1.9	0.71
46	2.0	1.7	0.58	2.1	1.8	0.59	2.1	1.8	0.60	2.2	1.9	0.61	2.3	1.8	0.62	2.4	1.8	0.62	2.5	1.8	0.64

Heating

TC : Total Capacity, PI : Power Input

Outdoor Temperature (°C, DB)	Indoor Temperature (°C, DB)											
	16		18		20		21		22		24	
	TC	PI	TC	PI	TC	PI	TC	PI	TC	PI	TC	PI
	kW	kW	kW	kW	kW	kW	kW	kW	kW	kW	kW	kW
-20	2.3	1.15	2.3	1.14	2.3	1.13	2.3	1.12	2.2	1.11	2.2	1.10
-15	2.9	1.33	2.9	1.32	2.9	1.31	2.8	1.29	2.8	1.28	2.8	1.27
-5	3.3	1.24	3.3	1.23	3.2	1.22	3.2	1.21	3.2	1.19	3.1	1.18
0	3.4	1.06	3.4	1.05	3.4	1.04	3.3	1.03	3.3	1.02	3.3	1.01
7	3.4	0.89	3.3	0.88	3.3	0.87	3.3	0.86	3.2	0.85	3.2	0.84
24	4.4	1.02	4.3	1.01	4.3	1.00	4.2	0.99	4.2	0.98	4.2	0.97

NOTE

- The performance table shows the average value of each conditions.

3. Capacity Table

LSP Duct

(2) AC035RNLDKG/EU+AC035RXADKG/EU

Cooling

TC : Total Capacity, SHC : Sensible Heat Capacity, PI : Power Input

Outdoor Temperature (°C, DB)	Indoor Temperature (°C, DB / WB)																				
	20 / 14			22 / 16			25 / 18			27 / 19			28 / 20			30 / 22			32 / 24		
	TC	SHC	PI	TC	SHC	PI	TC	SHC	PI	TC	SHC	PI	TC	SHC	PI	TC	SHC	PI	TC	SHC	PI
	kW	kW	kW	kW	kW	kW	kW	kW	kW	kW	kW	kW	kW	kW	kW	kW	kW	kW	kW	kW	kW
-15	3.4	2.5	0.80	3.6	2.6	0.82	3.7	2.7	0.83	3.9	2.8	0.85	3.9	2.7	0.86	4.1	2.7	0.87	4.3	2.6	0.89
21	3.3	2.4	0.84	3.4	2.5	0.86	3.6	2.5	0.88	3.7	2.6	0.90	3.7	2.6	0.90	3.9	2.6	0.91	4.1	2.5	0.93
35	3.1	2.3	1.05	3.3	2.4	1.08	3.4	2.4	1.10	3.5	2.5	1.12	3.6	2.5	1.13	3.7	2.5	1.14	3.9	2.4	1.17
46	2.6	2.3	0.95	2.8	2.4	0.97	2.9	2.4	0.99	3.0	2.5	1.01	3.0	2.5	1.02	3.2	2.5	1.03	3.3	2.4	1.05

Heating

TC : Total Capacity, PI : Power Input

Outdoor Temperature (°C, DB)	Indoor Temperature (°C, DB)											
	16		18		20		21		22		24	
	TC	PI	TC	PI	TC	PI	TC	PI	TC	PI	TC	PI
	kW	kW	kW	kW	kW	kW	kW	kW	kW	kW	kW	kW
-20	2.8	1.60	2.8	1.59	2.8	1.57	2.7	1.56	2.7	1.54	2.7	1.53
-15	3.5	1.85	3.5	1.83	3.5	1.82	3.4	1.80	3.4	1.78	3.4	1.76
-5	4.0	1.73	4.0	1.71	3.9	1.69	3.9	1.68	3.8	1.66	3.8	1.64
0	4.2	1.48	4.1	1.47	4.1	1.45	4.0	1.44	4.0	1.42	4.0	1.41
7	4.1	1.23	4.0	1.22	4.0	1.21	4.0	1.20	3.9	1.19	3.9	1.17
24	5.3	1.42	5.3	1.41	5.2	1.39	5.1	1.38	5.1	1.36	5.0	1.35

NOTE

- The performance table shows the average value of each conditions.

3. Capacity Table

LSP Duct

(3) AC052RNLDKG/EU+AC052RXADKG/EU

Cooling

TC : Total Capacity, SHC : Sensible Heat Capacity, PI : Power Input

Outdoor Temperature (°C, DB)	Indoor Temperature (°C, DB / WB)																				
	20 / 14			22 / 16			25 / 18			27 / 19			28 / 20			30 / 22			32 / 24		
	TC	SHC	PI	TC	SHC	PI	TC	SHC	PI	TC	SHC	PI	TC	SHC	PI	TC	SHC	PI	TC	SHC	PI
	kW	kW	kW	kW	kW	kW	kW	kW	kW	kW	kW	kW	kW	kW	kW	kW	kW	kW	kW	kW	kW
-15	4.9	3.7	1.21	5.1	3.8	1.23	5.3	4.0	1.26	5.5	4.1	1.28	5.6	4.0	1.30	5.9	4.0	1.31	6.2	3.9	1.34
21	4.6	3.5	1.27	4.9	3.7	1.30	5.1	3.8	1.32	5.3	3.9	1.35	5.4	3.8	1.37	5.6	3.8	1.38	5.9	3.7	1.41
35	4.4	3.4	1.59	4.7	3.5	1.62	4.9	3.6	1.66	5.0	3.7	1.69	5.1	3.7	1.71	5.4	3.6	1.72	5.6	3.6	1.76
46	3.8	3.2	1.43	4.0	3.3	1.46	4.1	3.4	1.49	4.3	3.5	1.52	4.3	3.4	1.54	4.6	3.4	1.55	4.8	3.3	1.58
50	2.9	2.5	1.27	3.0	2.6	1.30	3.2	2.6	1.32	3.3	2.7	1.35	3.3	2.7	1.37	3.5	2.7	1.38	3.7	2.6	1.41

Heating

TC : Total Capacity, PI : Power Input

Outdoor Temperature (°C, DB)	Indoor Temperature (°C, DB)											
	16		18		20		21		22		24	
	TC	PI	TC	PI	TC	PI	TC	PI	TC	PI	TC	PI
	kW	kW	kW	kW	kW	kW	kW	kW	kW	kW	kW	kW
-20	4.2	2.31	4.2	2.28	4.1	2.26	4.1	2.24	4.1	2.22	4.0	2.19
-15	5.3	2.66	5.3	2.64	5.2	2.61	5.2	2.58	5.1	2.56	5.1	2.53
-5	6.0	2.48	5.9	2.46	5.9	2.44	5.8	2.41	5.8	2.39	5.7	2.36
0	6.2	2.13	6.2	2.11	6.1	2.09	6.1	2.07	6.0	2.05	5.9	2.03
7	6.1	1.77	6.1	1.76	6.0	1.74	5.9	1.72	5.9	1.71	5.8	1.69
24	8.0	2.04	7.9	2.02	7.8	2.00	7.7	1.98	7.6	1.96	7.6	1.94

NOTE

- The performance table shows the average value of each conditions.

3. Capacity Table

LSP Duct

(4) AC071RNLDKG/EU+AC071RXADKG/EU

Cooling

TC : Total Capacity, SHC : Sensible Heat Capacity, PI : Power Input

Outdoor Temperature (°C, DB)	Indoor Temperature (°C, DB / WB)																				
	20 / 14			22 / 16			25 / 18			27 / 19			28 / 20			30 / 22			32 / 24		
	TC	SHC	PI	TC	SHC	PI	TC	SHC	PI	TC	SHC	PI	TC	SHC	PI	TC	SHC	PI	TC	SHC	PI
	kW	kW	kW	kW	kW	kW	kW	kW	kW	kW	kW	kW	kW	kW	kW	kW	kW	kW	kW	kW	kW
-15	6.9	5.3	1.70	7.3	5.5	1.74	7.6	5.7	1.77	7.8	5.8	1.81	8.0	5.8	1.83	8.4	5.7	1.84	8.8	5.6	1.88
21	6.6	5.1	1.79	6.9	5.2	1.83	7.2	5.4	1.87	7.5	5.6	1.90	7.6	5.5	1.92	8.0	5.5	1.94	8.4	5.3	1.98
35	6.3	4.8	2.24	6.6	5.0	2.29	6.9	5.1	2.33	7.1	5.3	2.38	7.2	5.2	2.40	7.6	5.2	2.43	8.0	5.1	2.48
46	5.3	4.5	2.02	5.6	4.6	2.06	5.9	4.8	2.10	6.0	4.9	2.14	6.2	4.9	2.16	6.5	4.8	2.18	6.8	4.7	2.23
50	4.1	3.5	1.79	4.3	3.6	1.83	4.5	3.8	1.87	4.6	3.9	1.90	4.7	3.8	1.92	4.9	3.8	1.94	5.2	3.7	1.98

Heating

TC : Total Capacity, PI : Power Input

Outdoor Temperature (°C, DB)	Indoor Temperature (°C, DB)											
	16		18		20		21		22		24	
	TC	PI	TC	PI	TC	PI	TC	PI	TC	PI	TC	PI
	kW	kW	kW	kW	kW	kW	kW	kW	kW	kW	kW	kW
-20	5.6	3.16	5.6	3.12	5.5	3.09	5.5	3.06	5.4	3.03	5.4	3.00
-15	7.1	3.64	7.0	3.61	7.0	3.57	6.9	3.53	6.8	3.50	6.8	3.46
-5	8.0	3.40	7.9	3.37	7.8	3.33	7.8	3.30	7.7	3.27	7.6	3.23
0	8.3	2.91	8.2	2.88	8.2	2.86	8.1	2.83	8.0	2.80	7.9	2.77
7	8.2	2.43	8.1	2.40	8.0	2.38	7.9	2.36	7.8	2.33	7.8	2.31
24	10.6	2.79	10.5	2.76	10.4	2.74	10.3	2.71	10.2	2.68	10.1	2.66

NOTE

- The performance table shows the average value of each conditions.

4. Dimensional Drawing

LSP Duct (Slim duct)

AC026/035RNLDKG/EU

Units : mm [inches]

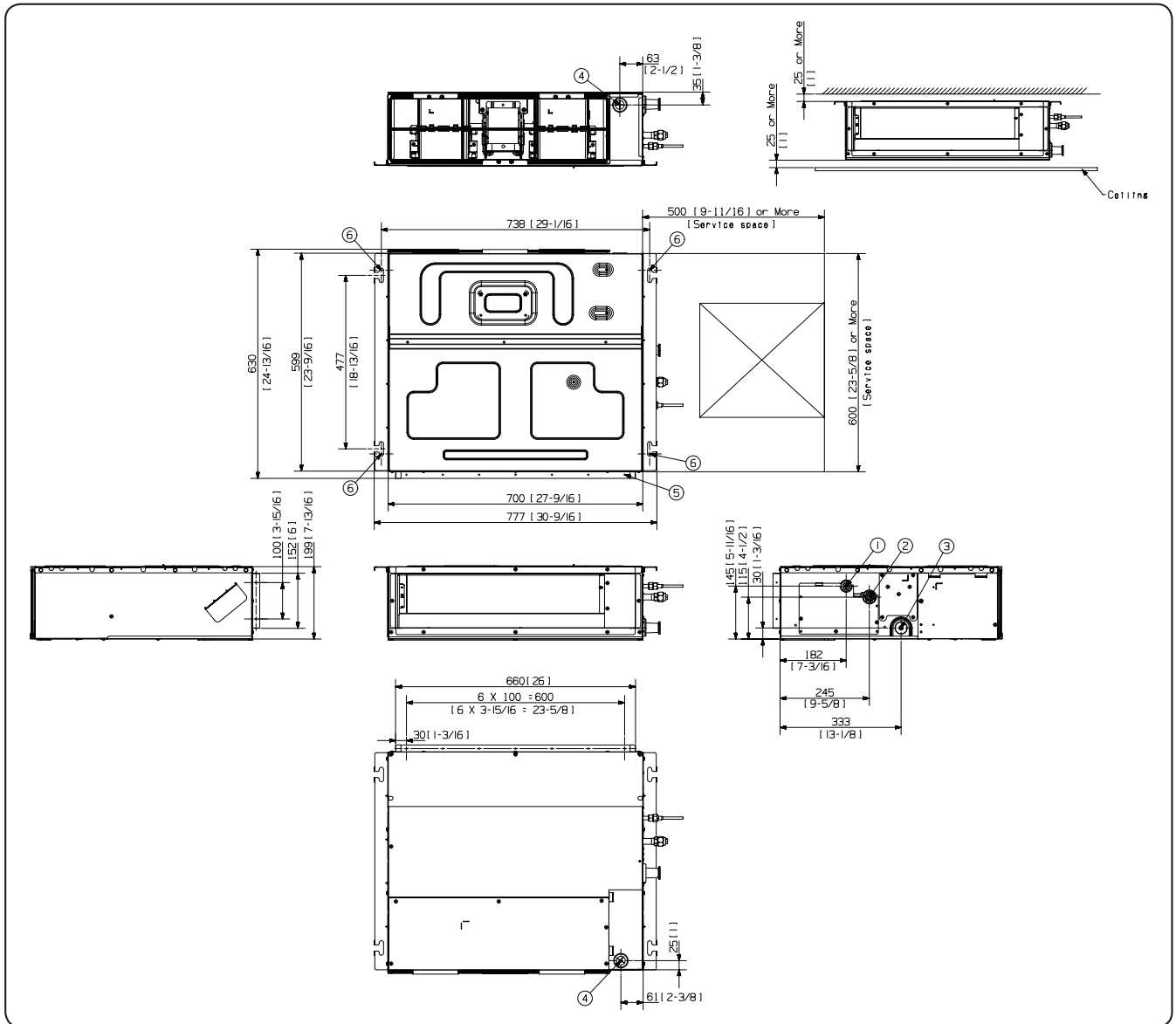

No.	Name	Description
1	Liquid pipe connection	Φ6.35(1/4)
2	Gas pipe connection	Φ9.52(3/8)
3	Drain pipe connection	VP-25(OD32, ID25)
4	Power supply & Communication wiring conduit	
5	Air suction flange	
6	Hook	Use M8~M10 bolt(4ea)

4. Dimensional Drawing

LSP Duct (Duct S)

AC052/071RNLDKG/EU

Units : mm [inches]

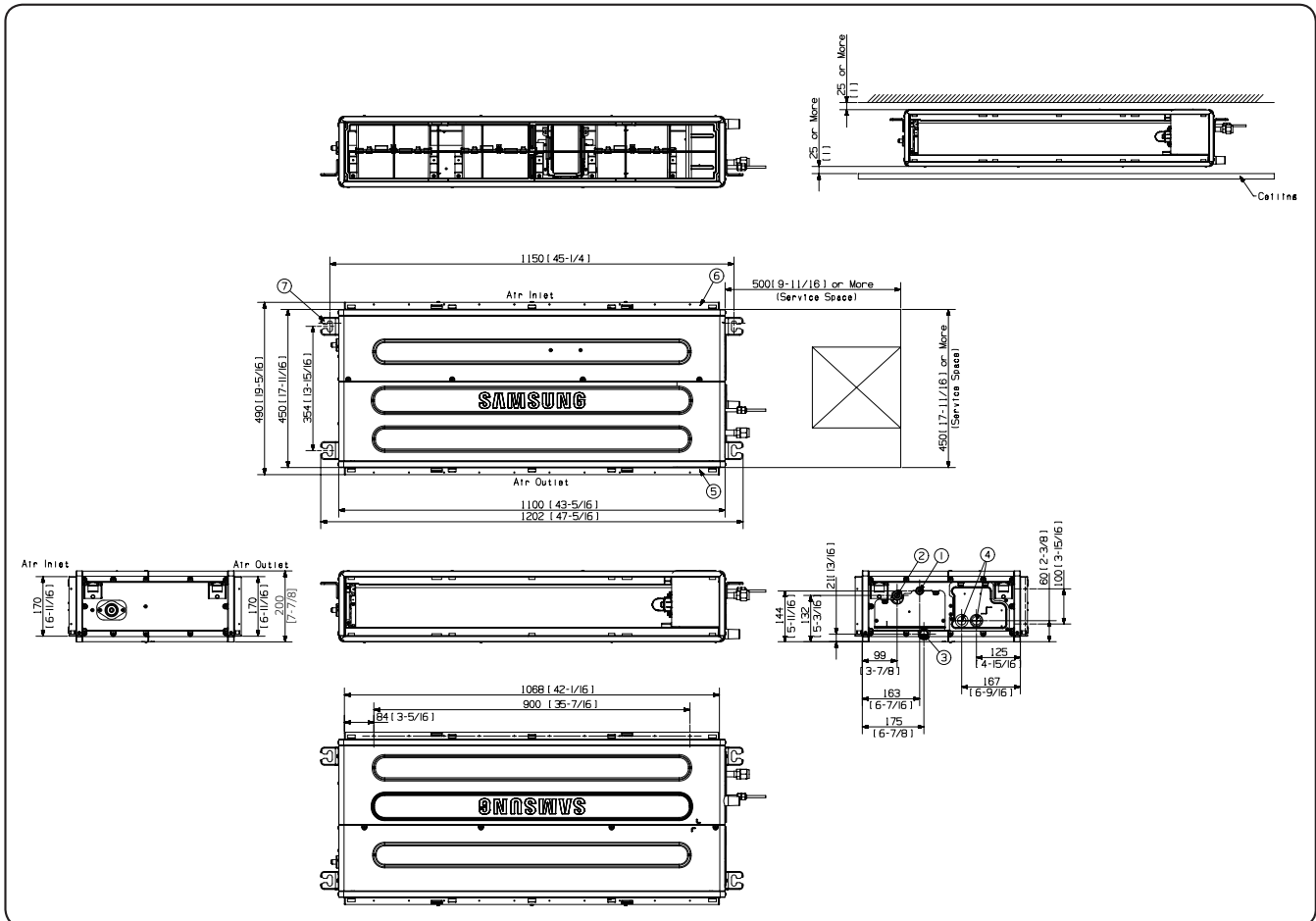

No.	Name	Description	
		AC052RNLDKG/EU	AC071RNLDKG/EU
1	Liquid pipe connection	Φ6.35(1/4)	
2	Gas pipe connection	Φ12.7(1/2)	Φ15.88(5/8)
3	Drain pipe connection	VP-25(OD32, ID25)	
4	Power supply & Communication wiring conduit		
5	Air suction flange		
6	Air discharge flange		
7	Hook	Use M8~M10 bolt(4ea)	

5. Center of Gravity

LSP Duct

AC026/035RNLDKG/EU

Units : mm [inches]

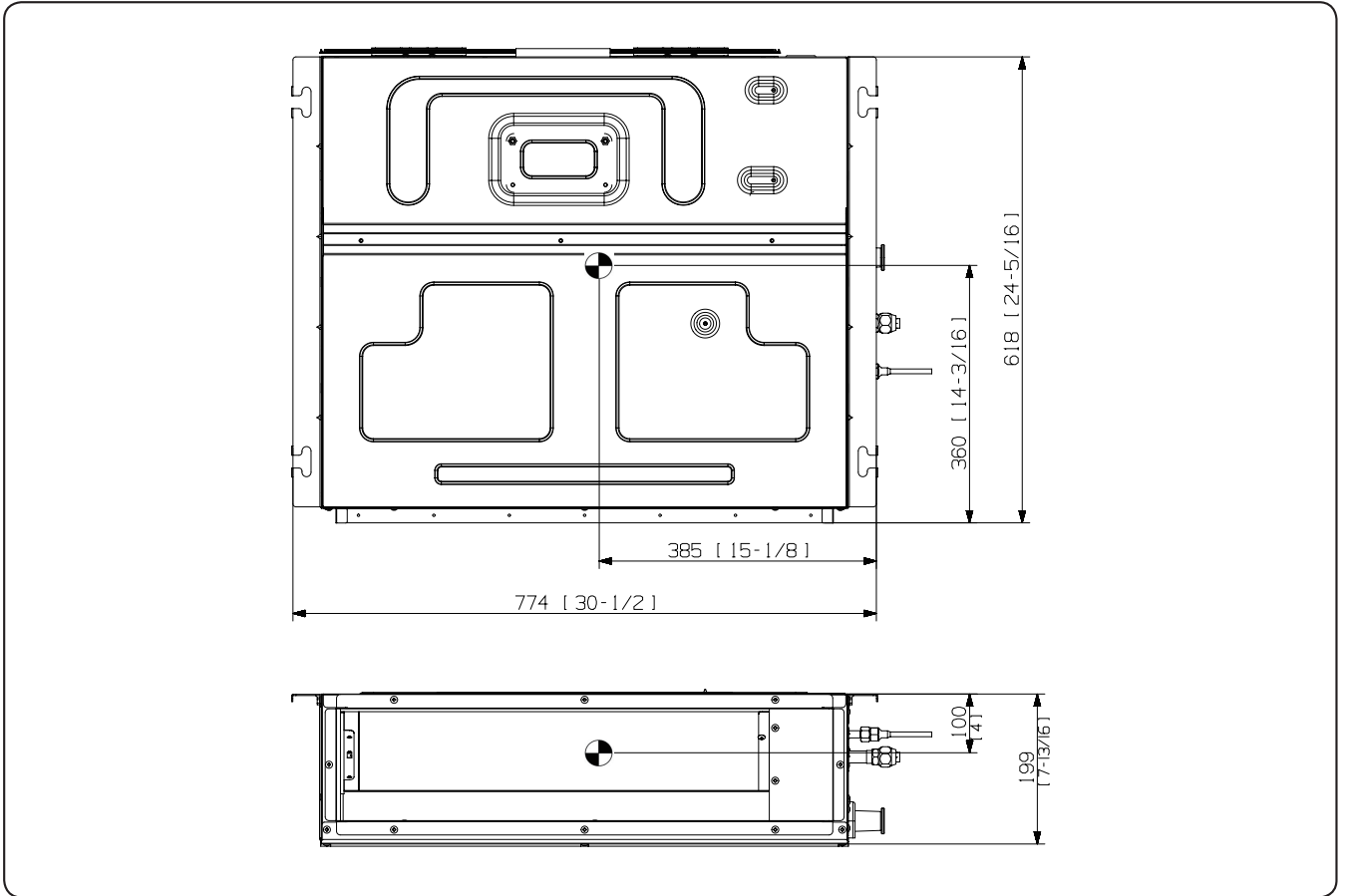

5. Center of Gravity

LSP Duct

AC052/071RNLDKG/EU

Units : mm [inches]

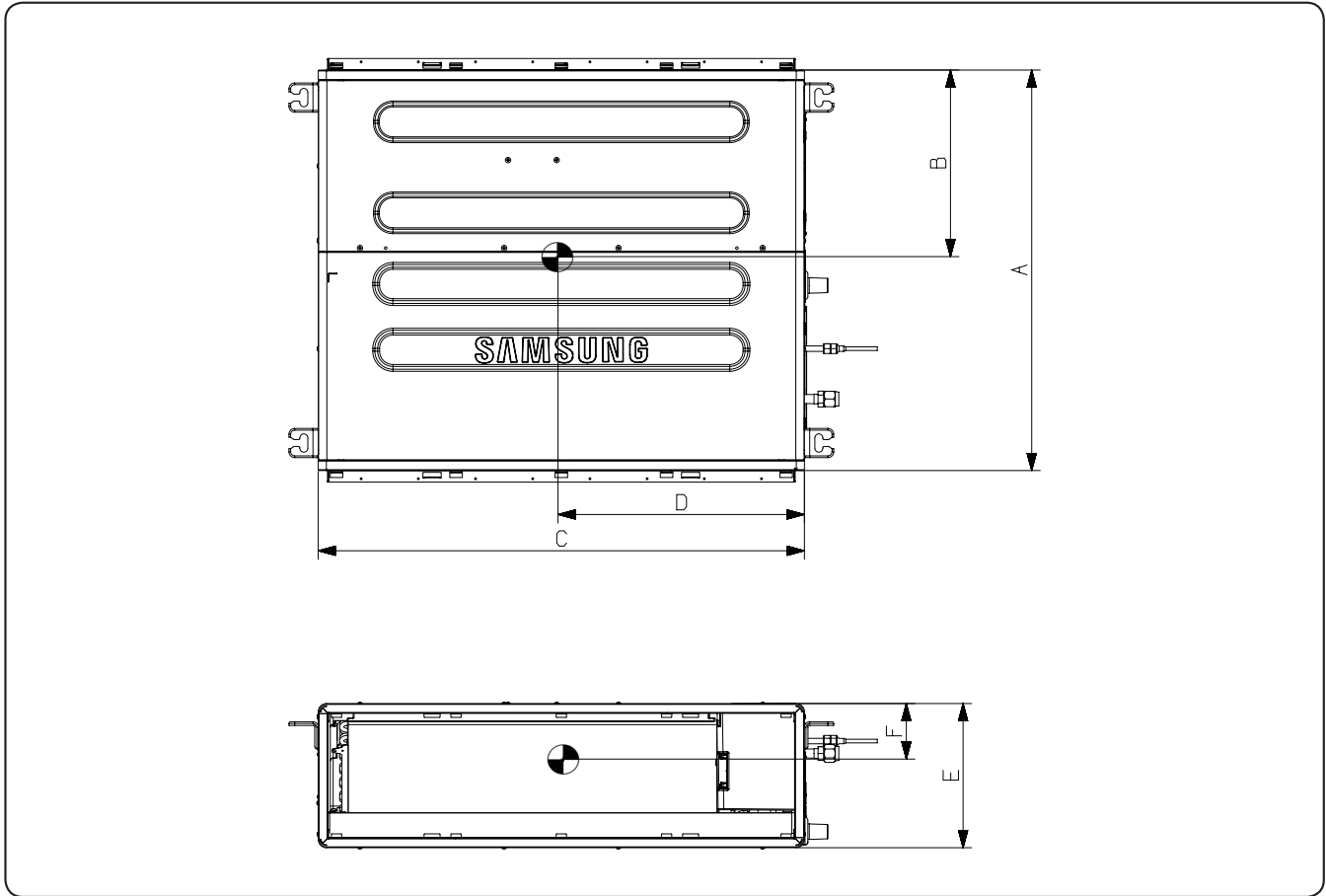

	A	B	C	D	E	F
5.2kW ~ 7.1kW	450 [17-11/16]	220 [8-5/8]	1100 [43-5/16]	520 [20-1/2]	200 [7-7/8]	100 [3-15/16]

6. Electrical Wiring Diagram

LSP Duct

AC026/035/052/071RNLDKG/EU

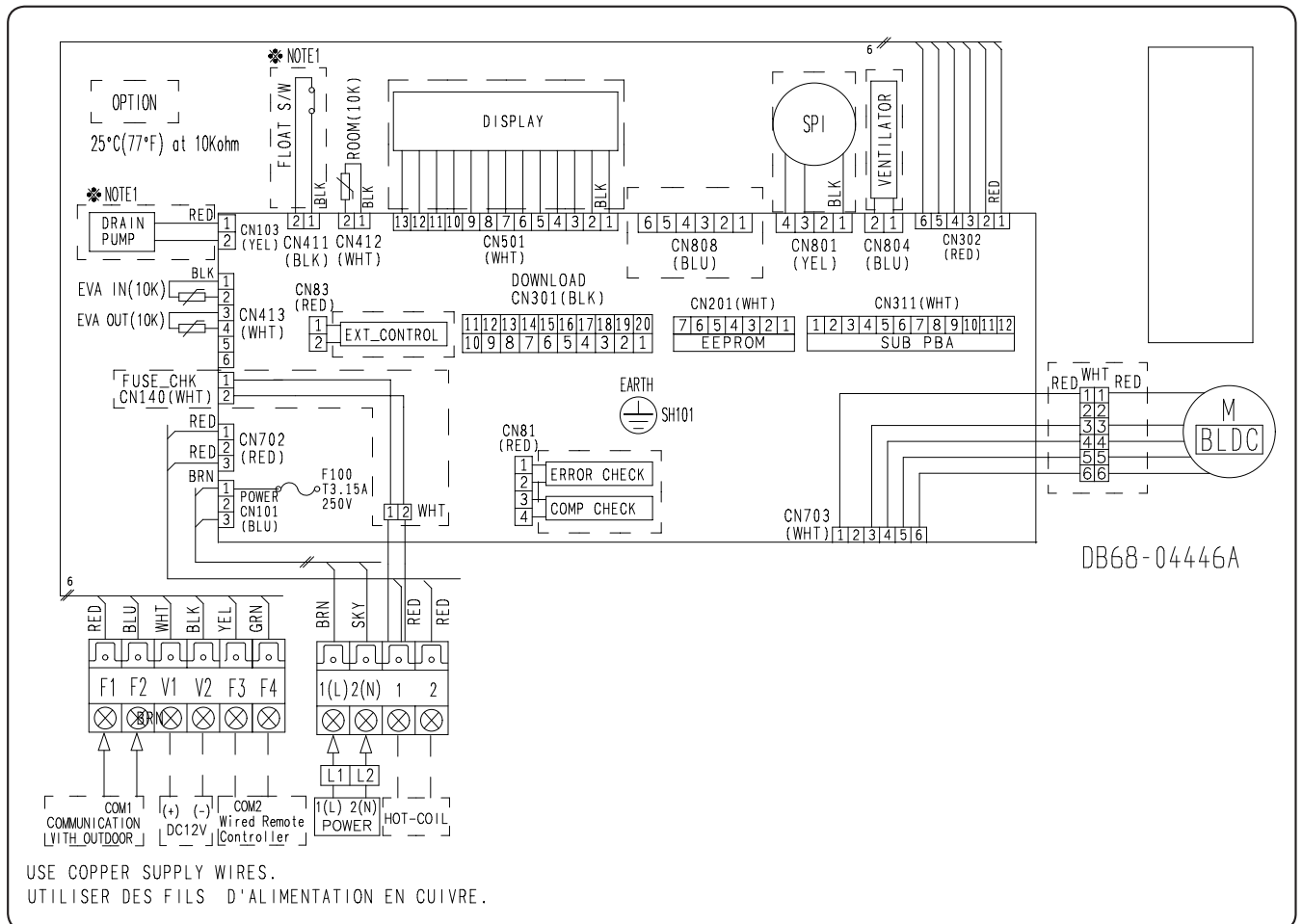

SPI	S-Plasma ion	EEV	Electronic Expansion Valve	ROOM	Thermistor ROOM in (10K)
FLOAT S/W	Switch of the float of Drain	EVA-IN	Thermistor EVA IN(10K)	EVA-OUT	Thermistor EVA OUT(10K)

NOTE

- This wiring diagram applies only to the Indoor unit.
- Symbols show as follow :
blk: black, red: red, blu: blue, wht: white, yel: yellow, brn: brown, sky: skyblue: grn: green
- For connection wiring indoor-outdoor transmission F1-F2, indoor-wired remote controller transmission F3-F4.
- Protective earth(screw)

7. Sound Data

LSP Duct

Sound Pressure level

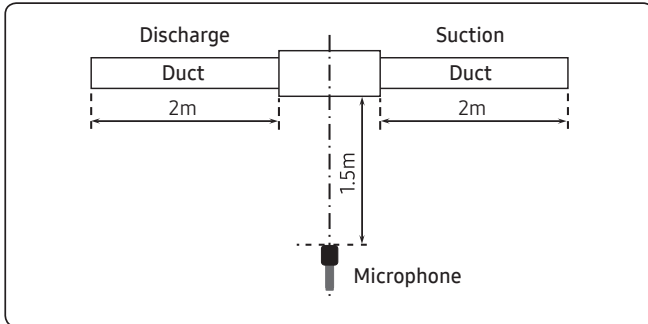

Unit: dB(A)

Model	HIGH	MID	LOW
AC026RNLDKG/EU	32	29	26
AC035RNLDKG/EU	33	30	27
AC052RNLDKG/EU	33	30	27
AC071RNLDKG/EU	37	32	27

- NR Curve

1) AC026RNLDKG/EU

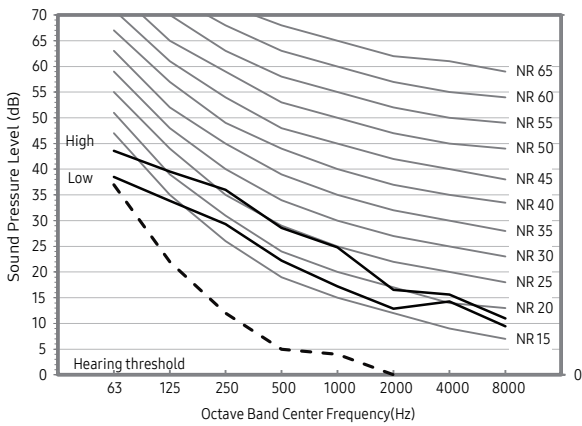

2) AC035RNLDKG/EU

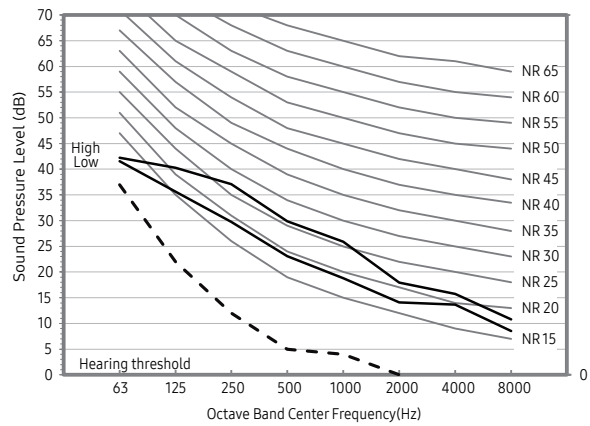

3) AC052RNLDKG/EU

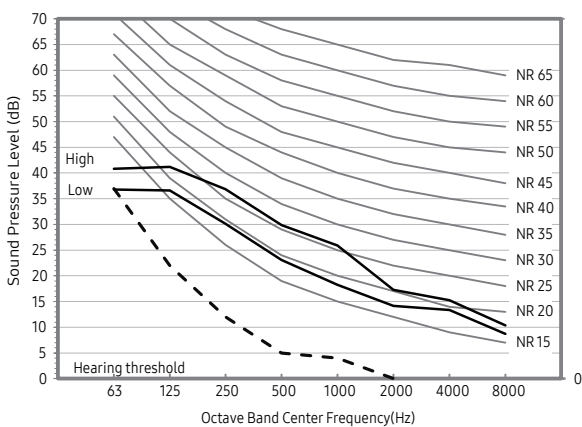

4) AC071RNLDKG/EU

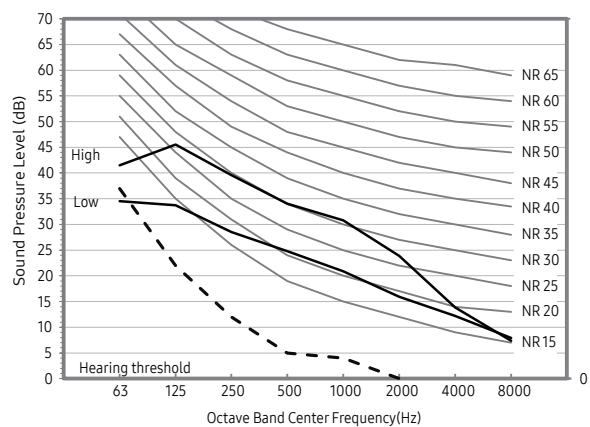

NOTE

- Specifications may be subject to change without prior notice.
 - Sound pressure level is obtained in an anechoic room.
 - Sound pressure level is a relative value, depending on the distance and acoustic environment.
 - Sound pressure level may differ depending on operation condition.
 - dBA = A weighted sound pressure level
 - Reference acoustic pressure 0 dB = 20μPa

7. Sound Data

LSP Duct

Sound Power level

NOTE

Unit: dB(A)

- Specifications may be subject to change without prior notice
 - Sound power level is an absolute value that a sound source generates.
 - dB(A) = A-weighted sound power level.
 - Reference power : 1pW.
 - Measured according to ISO 3741.

Model	Power
AC026RNLDKG/EU	53
AC035RNLDKG/EU	53
AC052RNLDKG/EU	55
AC071RNLDKG/EU	59

• NR Curve

1) AC026RNLDKG/EU

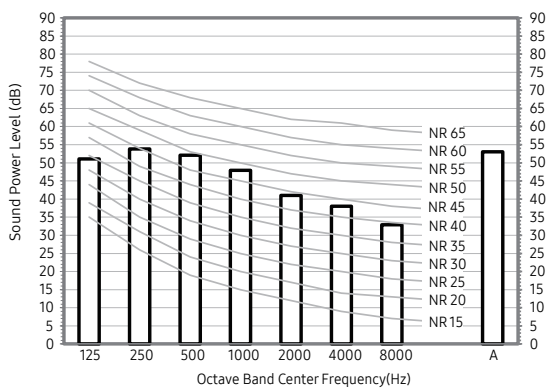

2) AC035RNLDKG/EU

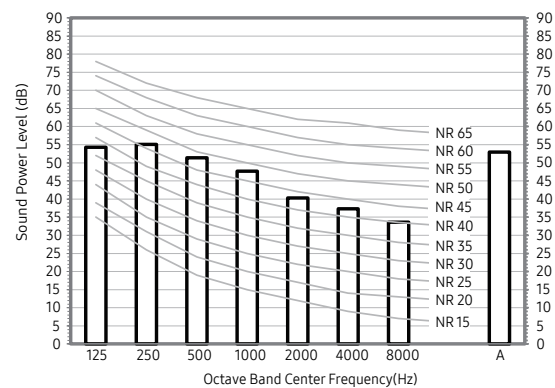

3) AC052RNLDKG/EU

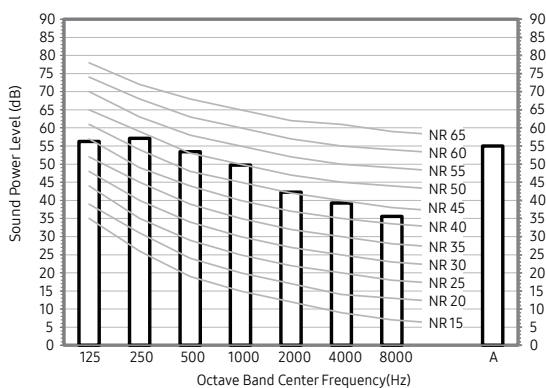

4) AC071RNLDKG/EU

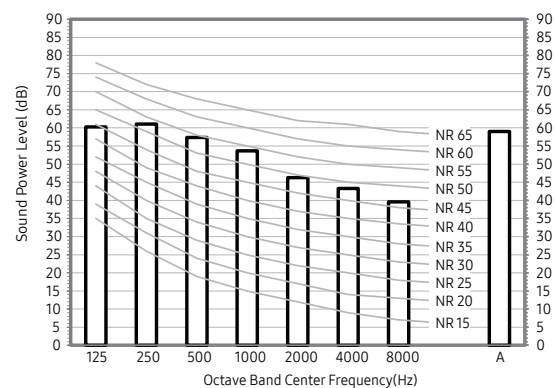

8. Fan Characteristics

LSP Duct

1) AC026RNLDKG/EU

①	External Static Pressure(mmAq)	Option Code
	0 ≤ SP ≤ 2.5	01C17C-1C1914-271A21-370000

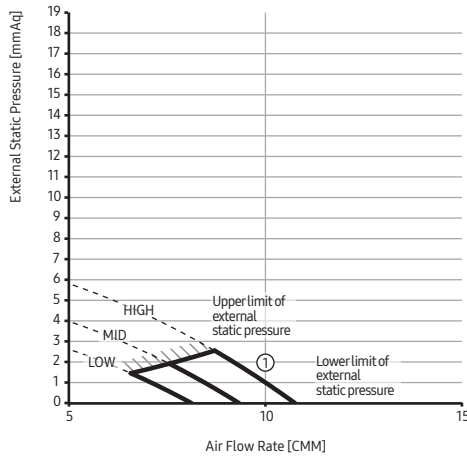

②	External Static Pressure(mmAq)	Option Code
	2.5 < SP ≤ 4	01C17C-1C1969-271A21-370000

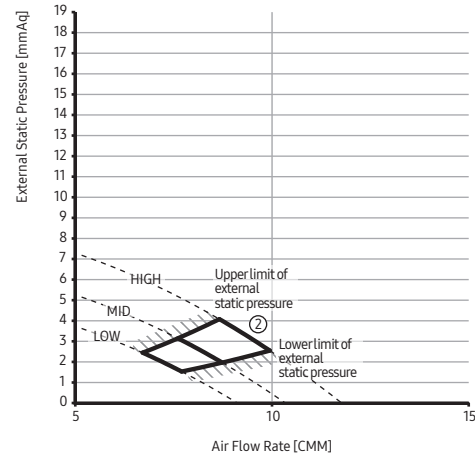

2) AC035RNLDKG/EU

①	External Static Pressure(mmAq)	Option Code
	0 ≤ SP ≤ 2.5	01C17C-1C3936-272328-370000

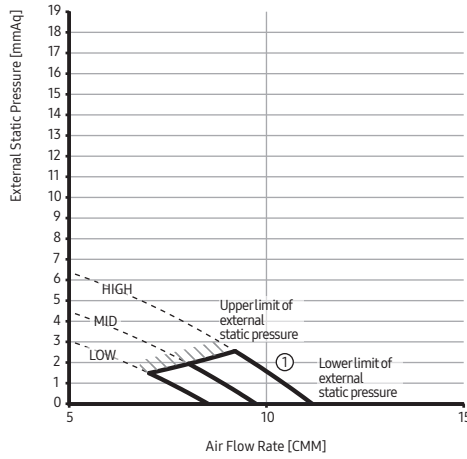

②	External Static Pressure(mmAq)	Option Code
	2.5 < SP ≤ 4	01C17C-1C39AD-272328-370000

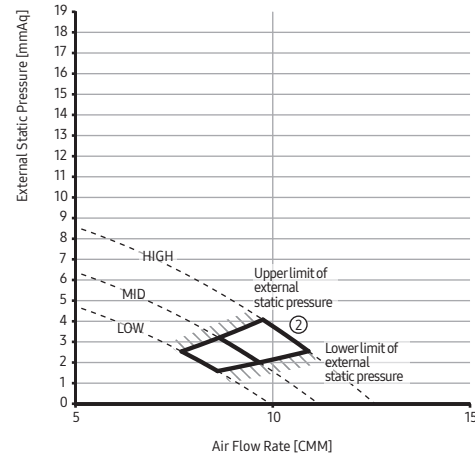

8. Fan Characteristics

LSP Duct

3) AC052RNLDKG/EU

①	External Static Pressure(mmAq)	Option Code
	$0 \leq SP \leq 3$	01C17C-1C1924-27343C-370000

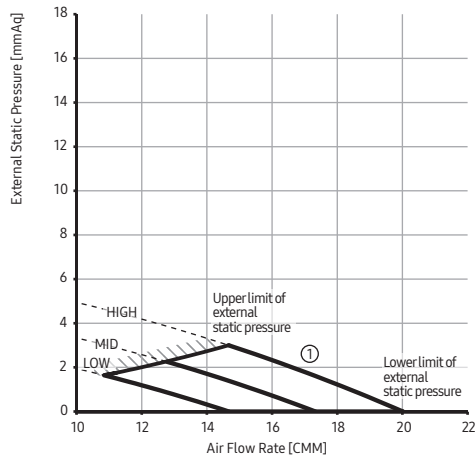

②	External Static Pressure(mmAq)	Option Code
	$3 < SP \leq 4$	01C17C-1C1968-27343C-370000

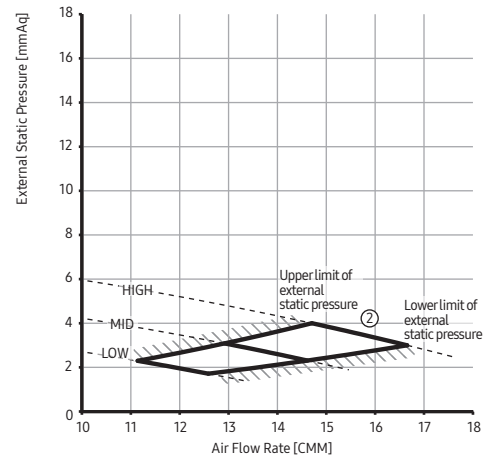

4) AC071RNLDKG/EU

①	External Static Pressure(mmAq)	Option Code
	$0 \leq SP \leq 3$	01C17C-1C59D0-274750-370005

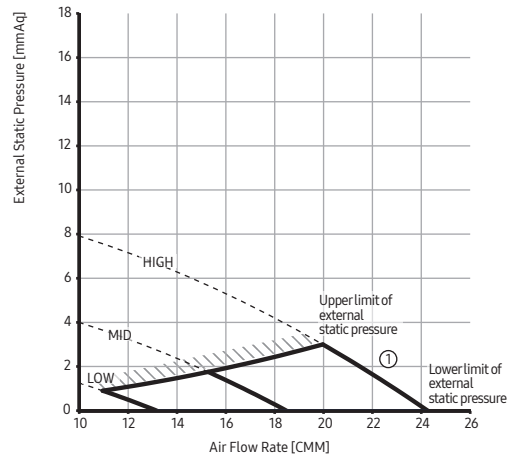

②	External Static Pressure(mmAq)	Option Code
	$3 < SP \leq 4$	01C17C-1C5D21-274750-370005

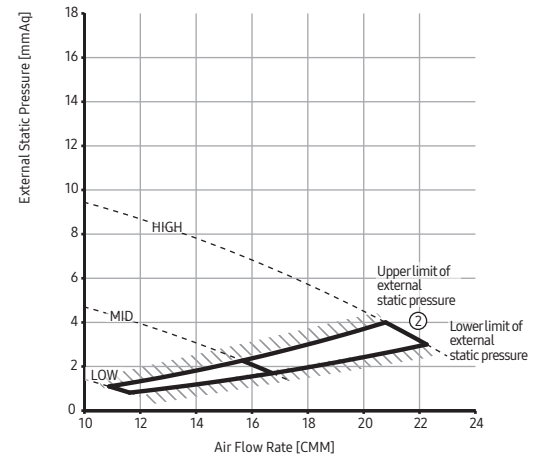

NOTE

- Adjust option code according to the actual installation condition (external static pressure).
- The graphs display the available external static pressure range of installed indoor units. Therefore, they do not reflect the actual change of external static pressure and airflow rate according to adjusted airflow (High-Mid-Low) of installed indoor units.

MSP Duct

1. Specification	97
2. Summary Table	100
3. Capacity Table	101
4. Dimensional Drawing	104
5. Center of Gravity	105
6. Electrical Wiring Diagram	106
7. Sound Data	107
8. Fan Characteristics	109

Features & Benefits

Duct S

Overview

Samsung Ducted Type air conditioning units are a smart solution for low-maintenance, consistent cooling and heating performance in any environment. Their compact, slim frame blends seamlessly into ceilings, enhancing the beauty of the interior space and affording users more flexible installation options. Offering a comprehensive lineup, Samsung Ducted Type air conditioning units offer just the right solution for every need--from the office or shop to the restaurant kitchen.

Experience performance and convenient comfort for any weather condition

Samsung Duct S delivers unparalleled cooling and heating and flexible management with customizable comfort settings in any climate—all year round. Plus, it boasts a slim, compact size and multiple access points for easy setup exactly where needed.



Smart pressure control

Samsung Ducted Type units feature a smart pressure control system. This system adjusts the fan speed based on the external static pressure (ESP), delivering consistent cooling and heating power, regardless of the surrounding environment.

Convenient installation

The optional lift-up drain pump lifts condensed water up to 750 mm, compared to a limit of 700 mm on conventional models, for flexible and convenient installation.

The Duct S indoor air conditioning unit delivers smooth, consistent operation and convenience with features such as:

- Efficient operation. Stage the desired atmosphere with energy-efficient performance and customized airflow.
- Smart management. Cool spaces efficiently and manage the air conditioning unit even while away, with features designed for efficiency and control.
- Easy, flexible setup. Install and maintain even multiple units with a compact and easily accessible design.

1. Specification

MSP Duct

Model Name	Indoor Unit			AC035RNMDKG/EU	AC052RNMDKG/EU	AC071RNMDKG/EU	
	Outdoor Unit			AC035RXADKG/EU	AC052RXADKG/EU	AC071RXADKG/EU	
Mode				-	HEAT PUMP	HEAT PUMP	HEAT PUMP
Performance	Capacity (Min/Std/Max)	Cooling	kW	0.80 / 3.50 / 4.40	1.20 / 5.00 / 6.50	1.50 / 6.80 / 8.70	
			Btu/h	2,730 / 11,940 / 15,010	4,100 / 17,060 / 22,180	5,120 / 23,200 / 29,690	
		Heating	kW	1.10 / 4.00 / 4.70	1.10 / 6.00 / 7.20	1.90 / 8.00 / 9.00	
			Btu/h	3,750 / 13,650 / 16,040	3,750 / 20,470 / 24,570	6,480 / 27,300 / 30,710	
Power	Power Input (Min/Std/Max)	Cooling	kW	0.20 / 1.02 / 1.36	0.35 / 1.60 / 2.20	0.35 / 2.32 / 3.60	
		Heating	kW	0.24 / 1.15 / 1.80	0.26 / 1.64 / 2.70	0.35 / 2.50 / 3.95	
	Current Input (Min/Std/Max)	Cooling	A	1.4 / 5.0 / 6.2	2.1 / 7.2 / 10.0	2.0 / 10.4 / 16.0	
		Heating	A	1.3 / 5.4 / 10.5	1.7 / 7.4 / 12.0	2.0 / 10.8 / 17.0	
	Current	MCA	A	12.5	19.0	19.0	
		MFA	A	13.8	20.9	20.9	
Efficiency	EER	Cooling	-	3.43	3.13	2.93	
	COP	Heating	-	3.48	3.66	3.20	
	SEER (Cooling Energy Grade)		-	6.4 (A++)	6.3 (A++)	6.1 (A++)	
	SCOP (Heating Energy Grade)		-	4.1 (A+)	4.1 (A+)	4.0 (A+)	
	Pdesignh		kW	2.0	2.4	3.7	
Piping Connections	Liquid Pipe		Type	Flare connection	Flare connection	Flare connection	
			Φ, mm (inch)	6.35 (1/4)	6.35 (1/4)	6.35 (1/4)	
	Gas Pipe		Type	Flare connection	Flare connection	Flare connection	
			Φ, mm (inch)	9.52 (3/8)	12.7 (1/2)	15.88 (5/8)	
	Heat Insulation		-	Both liquid and gas pipes	Both liquid and gas pipes	Both liquid and gas pipes	
	Piping length (ODU-IDU)	Standard	m	5	5	5	
		Max.	m	20	30	50	
Elevation		m	15	20	30		
Chargeless		m	20	10	15		
Wiring connections	Communication	Min.	mm ²	0.75	0.75	0.75	
		Remark	-	F1, F2	F1, F2	F1, F2	
Refrigerant	Type		-	R32	R32	R32	
	Factory Charging		kg	0.9	1.2	1.7	
			tCO ₂ e	0.61	0.81	1.15	

1. Specification

MSP Duct

	Model Name		Indoor Unit	AC035RNMDKG/EU	AC052RNMDKG/EU	AC071RNMDKG/EU	
			Outdoor Unit	AC035RXADKG/EU	AC052RXADKG/EU	AC071RXADKG/EU	
Indoor Unit	Power Supply		Ø, #, V, Hz	1,2,220-240,50	1,2,220-240,50	1,2,220-240,50	
	Heat Exchanger	Type		-	F&T	F&T	F&T
		Material	Fin	-	Al	Al	Al
			Tube	-	Cu	Cu	Cu
	Fin Treatment		-	Green Hydrophile	Green Hydrophile	Green Hydrophile	
	Fan	Type		-	Sirocco	Sirocco	Sirocco
		Quantity		EA	2	2	2
		Air Flow Rate	Cooling (H/M/L)	m ³ /min	10.4 / 9.2 / 8.0	14.5 / 12.0 / 9.5	17.0 / 14.0 / 11.0
				l/s	173.3 / 153.3 / 133.3	241.6 / 200 / 158.3	283.3 / 233.3 / 183.3
			Heating (H/M/L)	m ³ /min	10.4 / 9.2 / 8.0	14.5 / 12.0 / 9.5	17.0 / 14.0 / 11.0
				l/s	173.3 / 153.3 / 133.3	241.6 / 200 / 158.3	283.3 / 233.3 / 183.3
	External Static Pressure	Min/Std/Max	mmAq	0/2.5/15	0/3.0/15	0/3.0/15	
			Pa	0/25/147	0/29/147	0/29/147	
	Fan Motor	Type		-	BLDC	BLDC	BLDC
		Output		W x n	153	153	153
	Drain	Drain Pipe		Ø, mm	VP-25(OD32, ID25)	VP-25(OD32, ID25)	VP-25(OD32, ID25)
	Sound	Sound Pressure Level	High/Mid/Low/(Silent)	dB(A)	28 / 25 / 22	29 / 26 / 23	30 / 27 / 24
		Sound Power Level		dB(A)	52	55	56
	External Dimension	Net Weight		kg	26.5	26.5	26.5
		Shipping Weight		kg	30.5	30.5	30.5
		Net Dimensions (WxHxD)		mm	850 x 250 x 700	850 x 250 x 700	850 x 250 x 700
		Shipping Dimensions (WxHxD)		mm	1,064 x 320 x 784	1,064 x 320 x 784	1,064 x 320 x 784
	Casing	Material		-	EGI Steel Plate	EGI Steel Plate	EGI Steel Plate
	Control System	Infrared remote control		-	AR-EH03E	AR-EH03E	AR-EH03E
		Wired remote control		-	MWR-WE13N MWR-WG00*N	MWR-WE13N MWR-WG00*N	MWR-WE13N MWR-WG00*N
	Drain Pump	Drain Pump		-	-	-	-
		Max. lifting Height / Displacement		mm / Liter / h	-	-	-
	Additional Accessories	Drain Pump	External Model	-	MDP-G075SP	MDP-G075SP	MDP-G075SP
Internal Model			-	MDP-G075SQ	MDP-G075SQ	MDP-G075SQ	
Max. lifting Height / Displacement			mm / Liter / h	750/24	750/24	750/24	
Air Filter		-	Removable / Washable	Removable / Washable	Removable / Washable		
Virus Doctor		-	Option	Option	Option		

1. Specification

MSP Duct

Model Name	Indoor Unit			AC035RNMDKG/EU	AC052RNMDKG/EU	AC071RNMDKG/EU
	Outdoor Unit			AC035RXADKG/EU	AC052RXADKG/EU	AC071RXADKG/EU
Power Supply			Ø, #, V, Hz	1, 2, 220-240, 50	1, 2, 220-240, 50	1, 2, 220-240, 50
Heat Exchanger	Type		-	Fin & Tube	Fin & Tube	Fin & Tube
	Material	Fin	-	Al	Al	Al
		Tube	-	Cu	Cu	Cu
	Fin Treatment		-	Anti-Corrosion	Anti-Corrosion	Anti-Corrosion
Compressor	Model Name		-	UB9AK5090FER	UB9TK3150FE4	UB4TN8200FE4
	Type		-	Single BLDC	Twin BLDC	Twin BLDC
	Output		kW	0.86	1.51	1.89
	Oil	Type	-	POE	POE	POE
		Initial charge	cc	320	320	320
Fan	Type		-	Propeller	Propeller	Propeller
	Discharge direction		-	Front	Front	Front
	Quantity		EA	1	1	1
	Air Flow Rate		m ³ /min	30	40	51
l/s			500	667	850	
Fan Motor	Type		-	BLDC Motor	BLDC Motor	BLDC Motor
	Output		W x n	40 x 1	125 x 1	125 x 1
Sound	Sound Pressure Level	Cooling	dB(A)	48	48	49
		Heating	dB(A)	48	48	51
	Sound Power Level		dB(A)	61	62	65
External Dimension	Net Weight		kg	32.5	43.5	51.0
	Shipping Weight		kg	35.5	46.5	55.0
	Net Dimensions (WxHxD)		mm	790 x 548 x 285	880 x 638 x 310	880 x 798 x 310
	Shipping Dimensions (WxHxD)		mm	913 x 622 x 371	1,023 x 742 x 413	1,023 x 896 x 413
Casing	Material	Body	-	EGI Steel Plate	EGI Steel Plate	EGI Steel Plate
	Operating Temp. Range		°C	-15 ~ 46	-15 ~ 50	-15 ~ 50
		Heating	°C	-20 ~ 24	-20 ~ 24	-20 ~ 24

NOTE

- Specification may be subject to change without prior notice.
- 1) Performances are based on the following test conditions.
 - Cooling : Indoor temperature 27°C DB, 19°C WB, Outdoor temperature 35°C DB, 24°C WB
 - Heating : Indoor temperature 20°C DB, 15°C WB, Outdoor temperature 7°C DB, 6°C WB
 - Equivalent refrigerant pipe length 5m, Level differences 0m
- 2) Select wire size based on the value of MCA
- 3) Sound pressure level is obtained in an anechoic room.
 - Sound pressure level is a relative value, depending on the distance and acoustic environment.
 - Sound pressure level may differ depending on operation condition.
 - dBA = A-weighted sound pressure level
 - Reference acoustic pressure 0 dB = 20uPa
- 4) Sound power level is an absolute value that a sound source generates.
 - dBA = A-weighted sound power level
 - Reference power : 1pW
 - Measured according to ISO 3741
- 5) These products contain R32(GWP=675) which is fluorinated greenhouse gas.
- 6) 'MWR-WG00*N' is new wired remote control type(Graphic).
If you need the latest control system information, please refer to SAC control TDB.

2. Summary Table

MSP Duct

Performance Characteristics

Model Code	Net Weight (kg)	Capacity		Fan Speed	Airflow (CMM)	Sound Pressure Level (dBA)	Sound Power Level (dBA)	
		Cooling (kW)	Heating (kW)					
AC035RNMDKG/EU	25.8	Max.	4.40	4.70	High	10.4	28	52
		Std.	3.50	4.00	Mid	9.2	25	
		Min.	0.80	1.10	Low	8.0	22	
AC052RNMDKG/EU	25.8	Max.	6.50	7.20	High	14.5	29	55
		Std.	5.00	6.00	Mid	12.0	26	
		Min.	1.20	1.10	Low	9.5	23	
AC071RNMDKG/EU	25.8	Max.	8.70	9.00	High	17.0	30	56
		Std.	6.80	8.00	Mid	14.0	27	
		Min.	1.50	1.90	Low	11.0	24	

NOTE

- Sound data is based on cooling operation.

Electric Characteristics

Model		Outdoor Unit				Input Current (Amperes)				Power Supply	
Indoor Unit	Outdoor Unit	Rated Hz	Voltage range			Outdoor Unit		Indoor Unit	Total	MCA(A)	MFA(A)
			Volts	Min.	Max.	Cooling	Heating				
AC035RNMDKG/EU	AC035RXADKG/EU	50	220 to 240	198	264	10	10	2.5	12.5	12.5	13.8
AC052RNMDKG/EU	AC052RXADKG/EU	50	220 to 240	198	264	16.5	16.5	2.5	19.0	19.0	20.9
AC071RNMDKG/EU	AC071RXADKG/EU	50	220 to 240	198	264	16.5	16.5	2.5	19.0	19.0	20.9

NOTE

- MCA : Minimum circuit amperes
- MFA : Maximum fuse amperes
- Select wire size based on the value of MCA

3. Capacity Table

MSP Duct

(1) AC035RNMDKG/EU+AC035RXADKG/EU

Cooling

TC : Total Capacity, SHC : Sensible Heat Capacity, PI : Power Input

Outdoor Temperature (°C, DB)	Indoor Temperature (°C, DB / WB)																				
	20 / 14			22 / 16			25 / 18			27 / 19			28 / 20			30 / 22			32 / 24		
	TC	SHC	PI	TC	SHC	PI	TC	SHC	PI	TC	SHC	PI	TC	SHC	PI	TC	SHC	PI	TC	SHC	PI
	kW	kW	kW	kW	kW	kW	kW	kW	kW	kW	kW	kW	kW	kW	kW	kW	kW	kW	kW	kW	kW
-15	3.4	2.7	0.73	3.6	2.8	0.74	3.7	2.9	0.76	3.9	3.0	0.78	3.9	2.9	0.78	4.1	2.9	0.79	4.3	2.9	0.81
21	3.3	2.6	0.77	3.4	2.7	0.78	3.6	2.7	0.80	3.7	2.8	0.82	3.7	2.8	0.82	3.9	2.8	0.83	4.1	2.7	0.85
35	3.1	2.5	0.96	3.3	2.5	0.98	3.4	2.6	1.00	3.5	2.7	1.02	3.6	2.7	1.03	3.7	2.6	1.04	3.9	2.6	1.06
46	2.6	2.4	0.86	2.8	2.4	0.88	2.9	2.5	0.90	3.0	2.6	0.92	3.0	2.5	0.93	3.2	2.5	0.94	3.3	2.5	0.96

Heating

TC : Total Capacity, PI : Power Input

Outdoor Temperature (°C, DB)	Indoor Temperature (°C, DB)											
	16		18		20		21		22		24	
	TC	PI	TC	PI	TC	PI	TC	PI	TC	PI	TC	PI
	kW	kW	kW	kW	kW	kW	kW	kW	kW	kW	kW	kW
-20	2.8	1.53	2.8	1.51	2.8	1.50	2.7	1.48	2.7	1.47	2.7	1.45
-15	3.5	1.76	3.5	1.74	3.5	1.73	3.4	1.71	3.4	1.69	3.4	1.67
-5	4.0	1.64	4.0	1.63	3.9	1.61	3.9	1.59	3.8	1.58	3.8	1.56
0	4.2	1.41	4.1	1.39	4.1	1.38	4.0	1.37	4.0	1.35	4.0	1.34
7	4.1	1.17	4.0	1.16	4.0	1.15	4.0	1.14	3.9	1.13	3.9	1.12
24	5.3	1.35	5.3	1.34	5.2	1.32	5.1	1.31	5.1	1.30	5.0	1.28

NOTE

- The performance table shows the average value of each conditions.

2. Summary Table

MSP Duct

(2) AC052RNMDKG/EU+AC052RXADKG/EU

Cooling

TC : Total Capacity, SHC : Sensible Heat Capacity, PI : Power Input

Outdoor Temperature (°C, DB)	Indoor Temperature (°C, DB / WB)																				
	20 / 14			22 / 16			25 / 18			27 / 19			28 / 20			30 / 22			32 / 24		
	TC	SHC	PI	TC	SHC	PI	TC	SHC	PI	TC	SHC	PI	TC	SHC	PI	TC	SHC	PI	TC	SHC	PI
	kW	kW	kW	kW	kW	kW	kW	kW	kW	kW	kW	kW	kW	kW	kW	kW	kW	kW	kW	kW	kW
-15	4.9	3.8	1.14	5.1	3.9	1.17	5.3	4.1	1.19	5.5	4.2	1.22	5.6	4.1	1.23	5.9	4.1	1.24	6.2	4.0	1.27
21	4.6	3.6	1.20	4.9	3.8	1.23	5.1	3.9	1.25	5.3	4.0	1.28	5.4	4.0	1.29	5.6	3.9	1.31	5.9	3.8	1.33
35	4.4	3.5	1.51	4.7	3.6	1.54	4.9	3.7	1.57	5.0	3.8	1.60	5.1	3.8	1.62	5.4	3.7	1.63	5.6	3.6	1.66
46	3.8	3.2	1.36	4.0	3.3	1.38	4.1	3.4	1.41	4.3	3.5	1.44	4.3	3.5	1.45	4.6	3.5	1.47	4.8	3.4	1.50
50	2.9	2.6	1.20	3.0	2.6	1.23	3.2	2.7	1.25	3.3	2.8	1.28	3.3	2.8	1.29	3.5	2.7	1.31	3.7	2.7	1.33

Heating

TC : Total Capacity, PI : Power Input

Outdoor Temperature (°C, DB)	Indoor Temperature (°C, DB)											
	16		18		20		21		22		24	
	TC	PI	TC	PI	TC	PI	TC	PI	TC	PI	TC	PI
	kW	kW	kW	kW	kW	kW	kW	kW	kW	kW	kW	kW
-20	4.2	2.17	4.2	2.15	4.1	2.13	4.1	2.11	4.1	2.09	4.0	2.07
-15	5.3	2.51	5.3	2.48	5.2	2.46	5.2	2.44	5.1	2.41	5.1	2.39
-5	6.0	2.34	5.9	2.32	5.9	2.30	5.8	2.27	5.8	2.25	5.7	2.23
0	6.2	2.01	6.2	1.99	6.1	1.97	6.1	1.95	6.0	1.93	5.9	1.91
7	6.1	1.67	6.1	1.66	6.0	1.64	5.9	1.62	5.9	1.61	5.8	1.59
24	8.0	1.92	7.9	1.90	7.8	1.89	7.7	1.87	7.6	1.85	7.6	1.83

NOTE

- The performance table shows the average value of each conditions.

2. Summary Table

MSP Duct

(3) AC071RNMDKG/EU+AC071RXADKG/EU

Cooling

TC : Total Capacity, SHC : Sensible Heat Capacity, PI : Power Input

Outdoor Temperature (°C, DB)	Indoor Temperature (°C, DB / WB)																				
	20 / 14			22 / 16			25 / 18			27 / 19			28 / 20			30 / 22			32 / 24		
	TC	SHC	PI	TC	SHC	PI	TC	SHC	PI	TC	SHC	PI	TC	SHC	PI	TC	SHC	PI	TC	SHC	PI
	kW	kW	kW	kW	kW	kW	kW	kW	kW	kW	kW	kW	kW	kW	kW	kW	kW	kW	kW	kW	kW
-15	6.6	4.9	1.66	7.0	5.1	1.69	7.3	5.2	1.73	7.5	5.4	1.76	7.6	5.3	1.78	8.0	5.3	1.80	8.4	5.2	1.83
21	6.3	4.7	1.75	6.6	4.8	1.78	6.9	5.0	1.82	7.1	5.1	1.86	7.3	5.1	1.87	7.6	5.0	1.89	8.0	4.9	1.93
35	6.0	4.5	2.18	6.3	4.6	2.23	6.6	4.8	2.27	6.8	4.9	2.32	6.9	4.9	2.34	7.3	4.8	2.37	7.6	4.7	2.41
46	5.1	4.2	1.97	5.4	4.4	2.01	5.6	4.5	2.05	5.8	4.6	2.09	5.9	4.6	2.11	6.2	4.5	2.13	6.5	4.4	2.17
50	3.9	3.3	1.75	4.1	3.5	1.78	4.3	3.6	1.82	4.4	3.7	1.86	4.5	3.6	1.87	4.7	3.6	1.89	5.0	3.5	1.93

Heating

TC : Total Capacity, PI : Power Input

Outdoor Temperature (°C, DB)	Indoor Temperature (°C, DB)											
	16		18		20		21		22		24	
	TC	PI	TC	PI	TC	PI	TC	PI	TC	PI	TC	PI
	kW	kW	kW	kW	kW	kW	kW	kW	kW	kW	kW	kW
-20	5.6	3.32	5.6	3.28	5.5	3.25	5.5	3.22	5.4	3.19	5.4	3.15
-15	7.1	3.83	7.0	3.79	7.0	3.75	6.9	3.71	6.8	3.68	6.8	3.64
-5	8.0	3.57	7.9	3.54	7.8	3.50	7.8	3.47	7.7	3.43	7.6	3.40
0	8.3	3.06	8.2	3.03	8.2	3.00	8.1	2.97	8.0	2.94	7.9	2.91
7	8.2	2.55	8.1	2.53	8.0	2.50	7.9	2.48	7.8	2.45	7.8	2.43
24	10.6	2.93	10.5	2.90	10.4	2.88	10.3	2.85	10.2	2.82	10.1	2.79

NOTE

- The performance table shows the average value of each conditions.

4. Dimensional Drawing

MSP Duct

AC035/052/071RNMDKG/EU

Units : mm [inches]

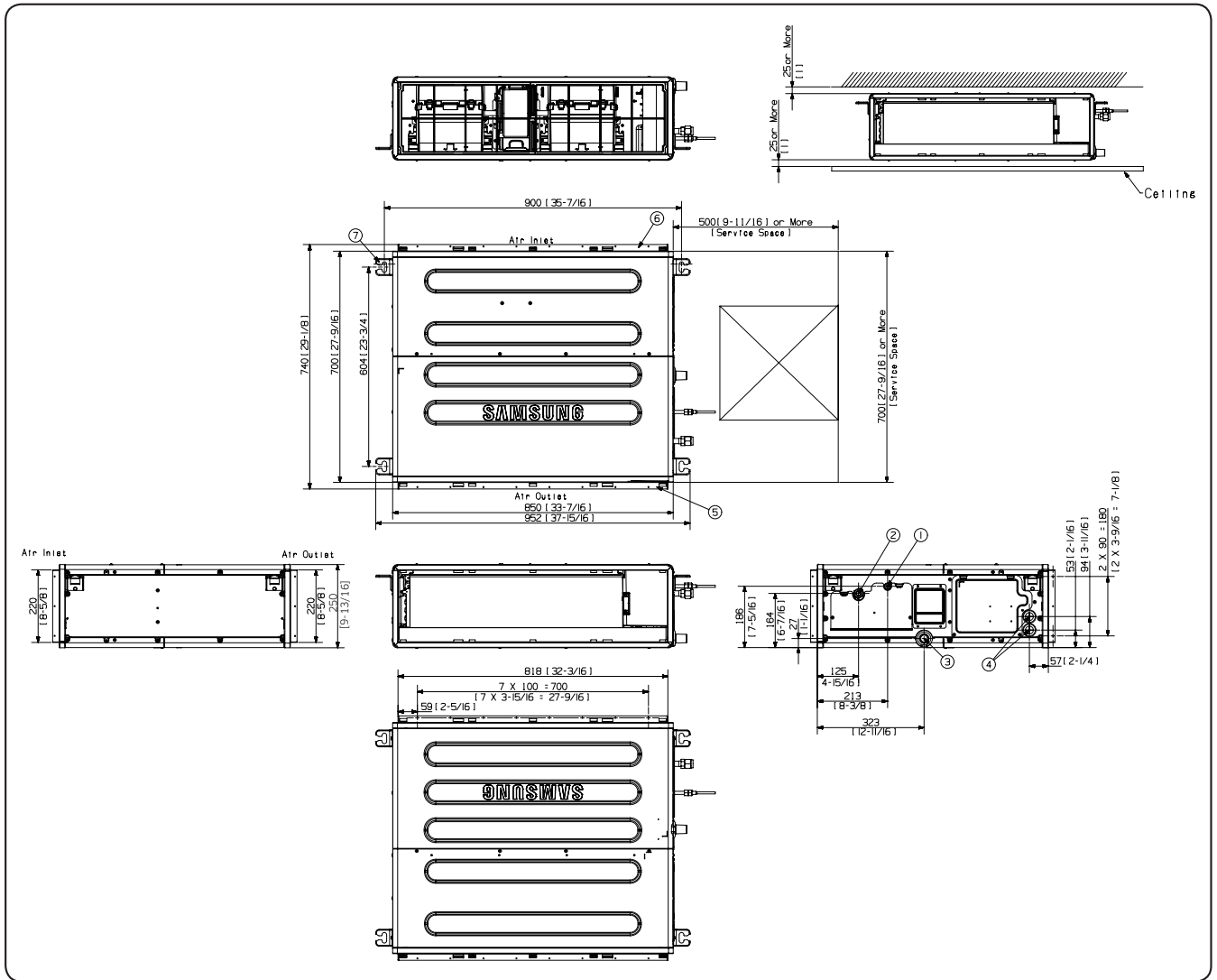

No.	Name	Description		
		AC035RNMDKG/EU	AC052RNMDKG/EU	AC071RNMDKG/EU
1	Liquid pipe connection		Φ6.35(1/4)	
2	Gas pipe connection	Φ9.52(3/8)	Φ12.7(1/2)	Φ15.88(5/8)
3	Drain pipe connection		VP-25(OD32, ID25)	
4	Power supply & Communication wiring conduit			
5	Air suction flange			
6	Air discharge flange			
7	Hook		Use M8-M10 bolt(4ea)	

5. Center of Gravity

MSP Duct

AC035/052/071RNMDKG/EU

Units : mm [inches]

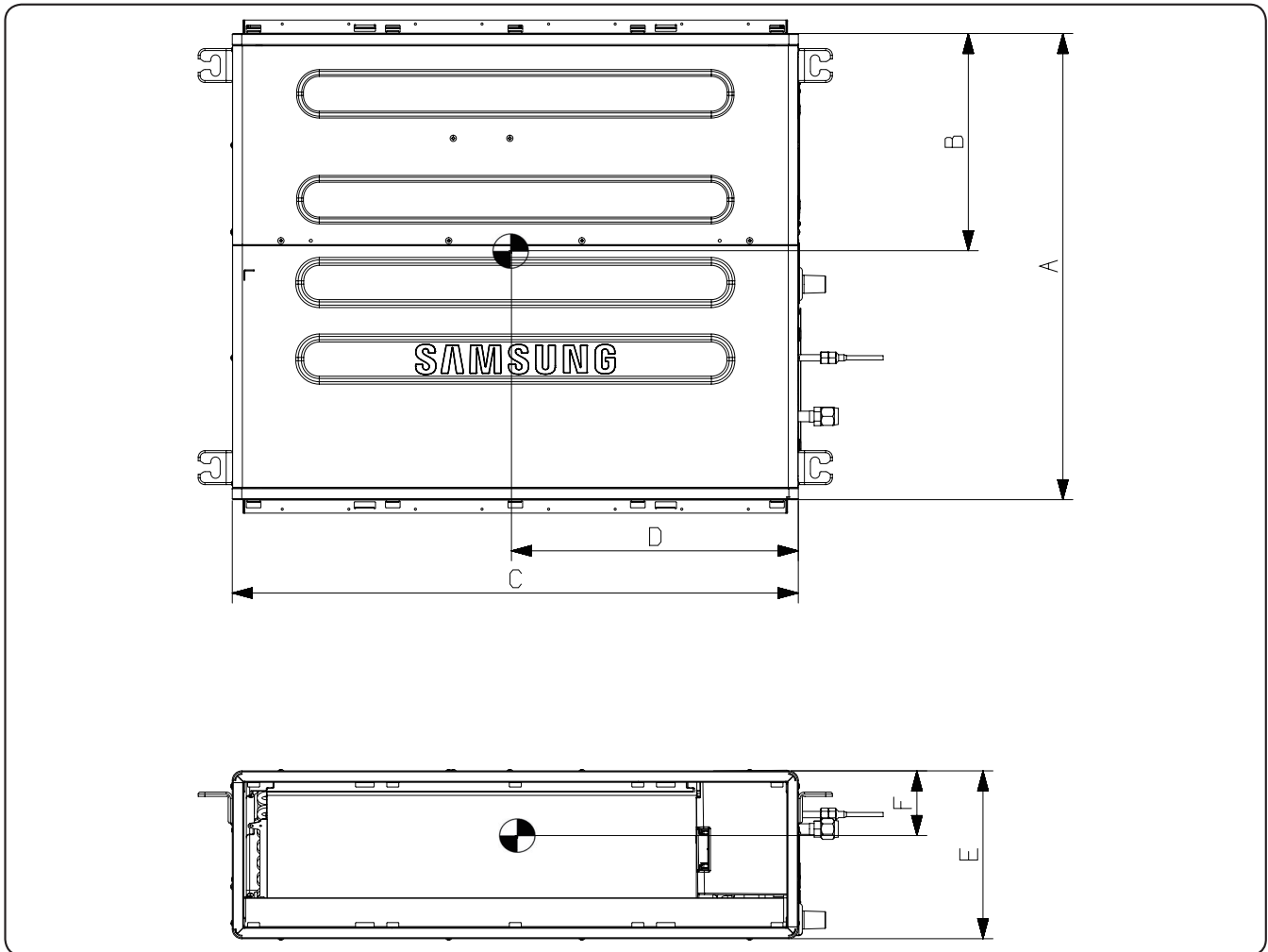

	A	B	C	D	E	F
~7.1kW	700 [27-9/16]	335 [14]	900 [35-7/16]	405 [15-15/16]	250 [9-13/16]	125 [4-15/16]
9.0kW ~ 10kW	700 [27-9/16]	265 [10-7/16]	1250 [49-3/16]	565 [18-5/16]	250 [9-13/16]	125 [4-15/16]
12kW ~ 14kW	700 [27-9/16]	265 [10-7/16]	1350 [53-1/8]	650 [25-5/8]	300 [11-13/16]	150 [5-15/16]

6. Electrical Wiring Diagram

MSP Duct

AC035/052/071RNMDKG/EU

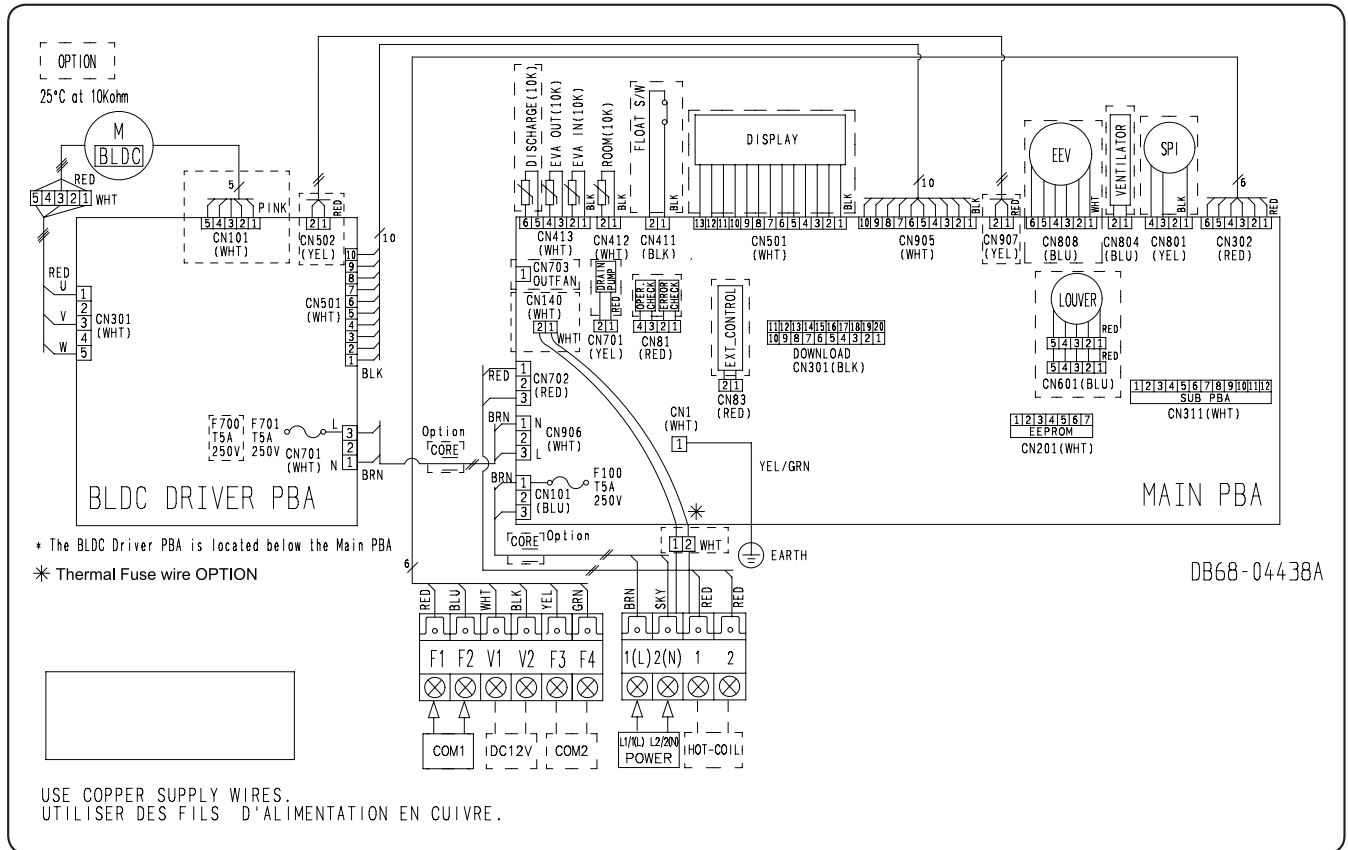

SPI	S-Plasma ion	EEV	Electronic Expansion Valve	ROOM	Thermistor ROOM in (10K)
M-BLDC	BLDC Motor	EVA-IN	Thermistor EVA IN(10K)	EVA-OUT	Thermistor EVA OUT(10K)

NOTE

- This wiring diagram applies only to the Indoor unit.
- Symbols show as follow :
blk: black, red: red, blu: blue, wht: white, yel: yellow, brn: brown, sky: skyblue: grn: green
- For connection wiring indoor-outdoor transmission F1-F2, indoor-wired remote controller transmission F3-F4.
- Protective earth(screw)

7. Sound Data

MSP Duct

Sound Pressure level

Unit: dB(A)

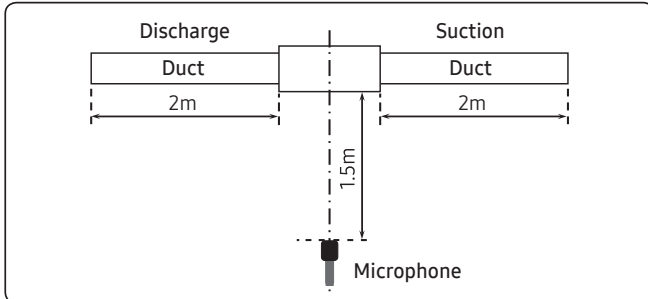

Model	HIGH	MID	LOW
AC035RNMDKG/EU	28	25	22
AC052RNMDKG/EU	29	26	23
AC071RNMDKG/EU	30	27	24

- NR Curve

1) AC035RNMDKG/EU

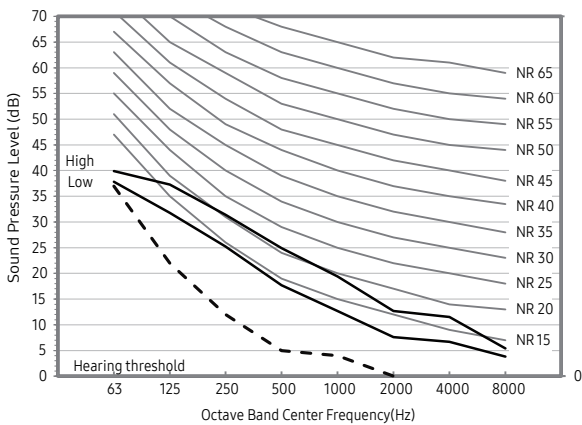

2) AC052RNMDKG/EU

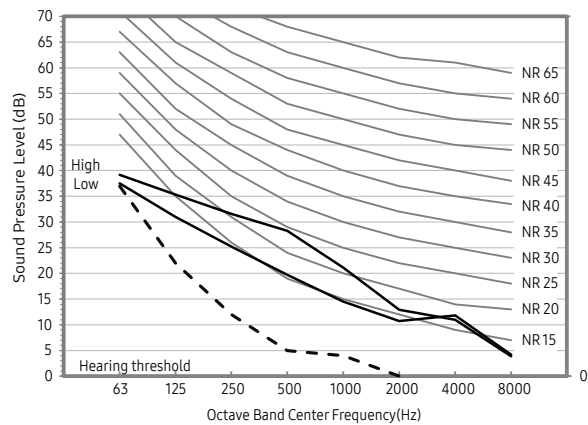

3) AC071RNMDKG/EU

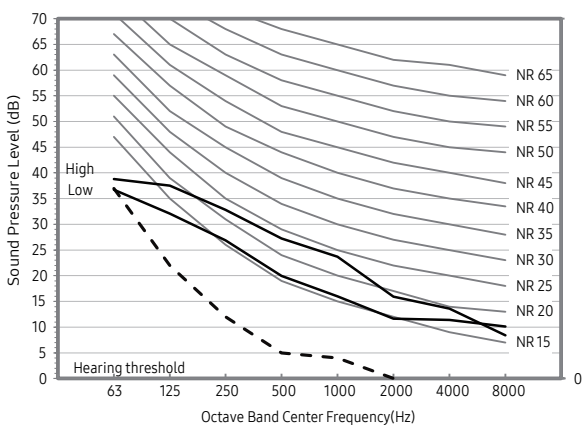

NOTE

- Specifications may be subject to change without prior notice.
 - Sound pressure level is obtained in an anechoic room.
 - Sound pressure level is a relative value, depending on the distance and acoustic environment.
 - Sound pressure level may differ depending on operation condition.
 - dBA = A weighted sound pressure level
 - Reference acoustic pressure 0 dB = 20μPa

6. Electrical Wiring Diagram

MSP Duct

Sound Power level

NOTE

Unit: dB(A)

- Specifications may be subject to change without prior notice
 - Sound power level is an absolute value that a sound source generates.
 - dB(A) = A-weighted sound power level.
 - Reference power : 1pW.
 - Measured according to ISO 3741.

Model	Power
AC035RNMDKG/EU	52
AC052RNMDKG/EU	55
AC071RNMDKG/EU	56

• NR Curve

1) AC035RNMDKG/EU

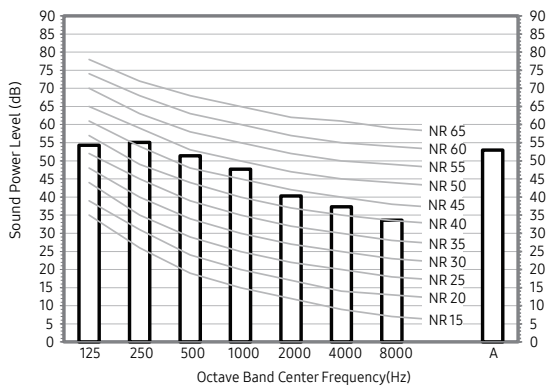

2) AC052RNMDKG/EU

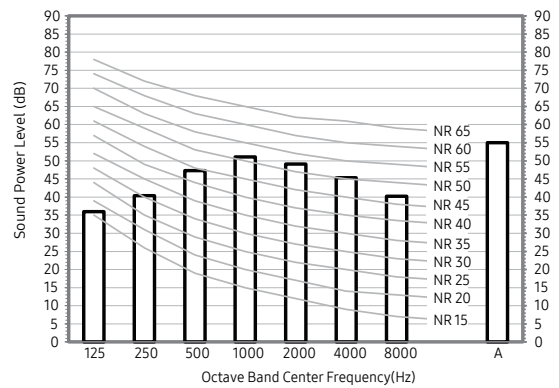

3) AC071RNMDKG/EU

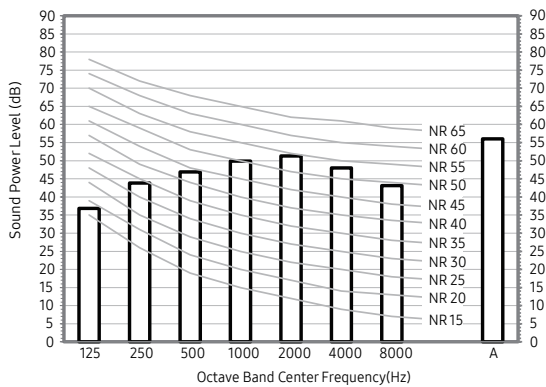

8. Fan Characteristics

MSP Duct

1) AC035RNMDKG/EU

①	External Static Pressure(mmAq)	Option Code
	0≤SP≤2.5	01B17C-1C5080-272328-372008

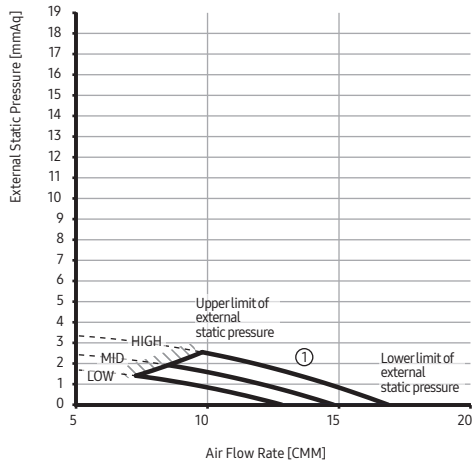

②	External Static Pressure(mmAq)	Option Code
	2.5<SP≤5	01B17C-1C5407-272328-372008

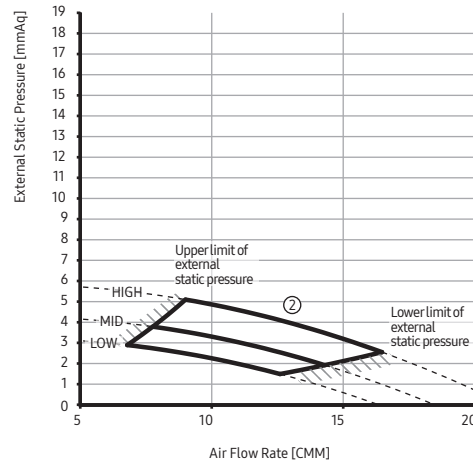

③	External Static Pressure(mmAq)	Option Code
	5<SP≤7.5	01B17C-1C548C-272328-372008

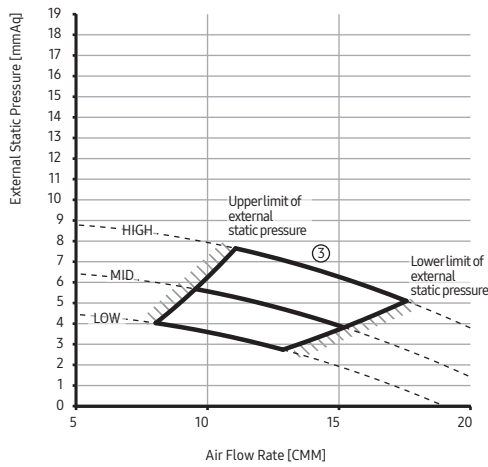

④	External Static Pressure(mmAq)	Option Code
	7.5<SP≤10	01B17C-1C55D3-272328-372008

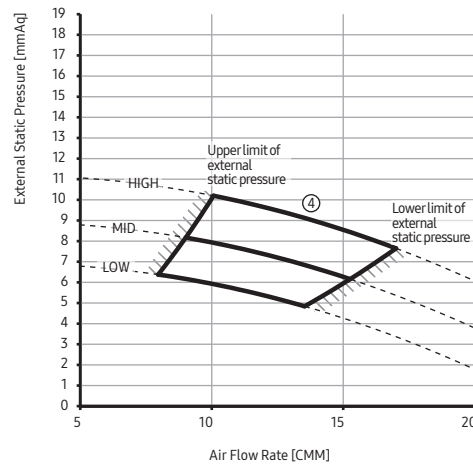

⑤	External Static Pressure(mmAq)	Option Code
	10<SP≤12.5	01B17C-1C5926-272328-372008

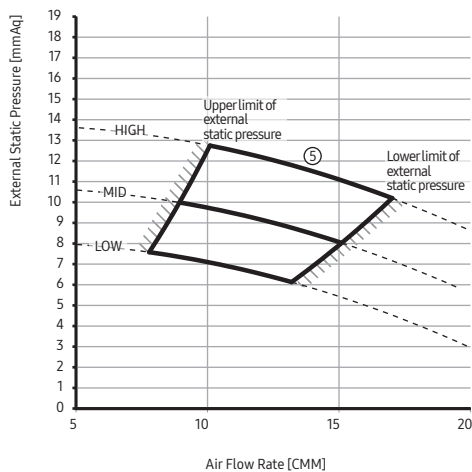

⑥	External Static Pressure(mmAq)	Option Code
	12.5<SP≤15	01B17C-1C5998-272328-372008

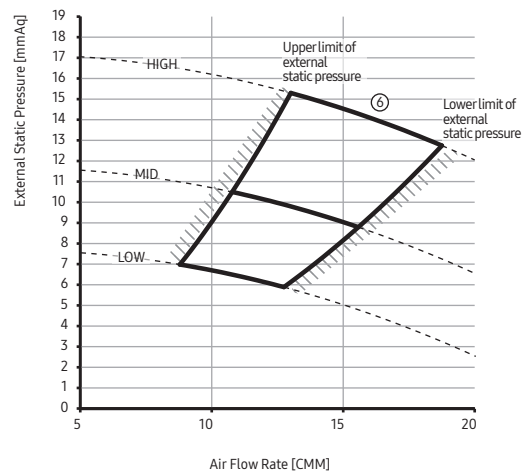

8. Fan Characteristics

MSP Duct

2) AC052RNMDKG/EU

①	External Static Pressure(mmAq)	Option Code
	0 ≤ SP ≤ 3	01B17C-1C50F1-27343C-374000

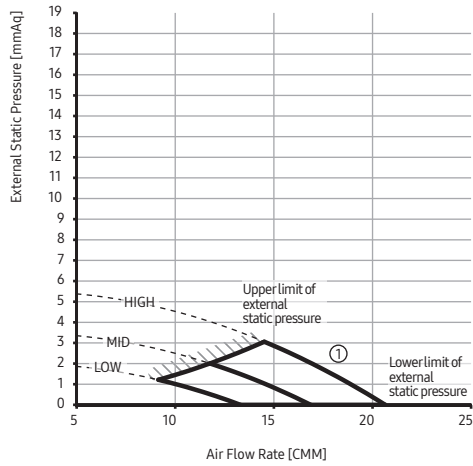

②	External Static Pressure(mmAq)	Option Code
	3 < SP ≤ 6	01B17C-1C5488-27343C-374000

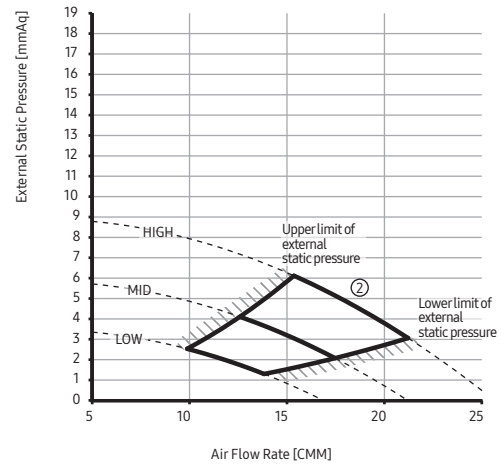

③	External Static Pressure(mmAq)	Option Code
	6 < SP ≤ 9	01B17C-1C54ED-27343C-374000

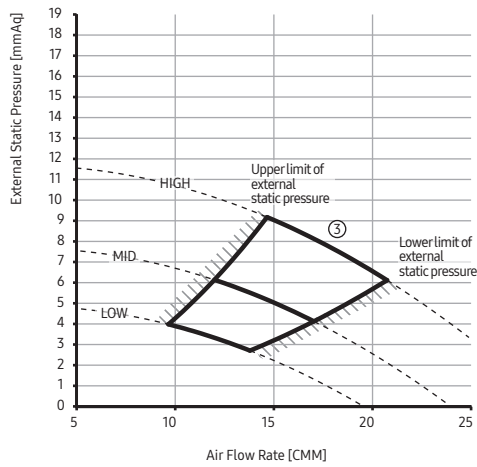

④	External Static Pressure(mmAq)	Option Code
	9 < SP ≤ 12	01B17C-1C5941-27343C-374000

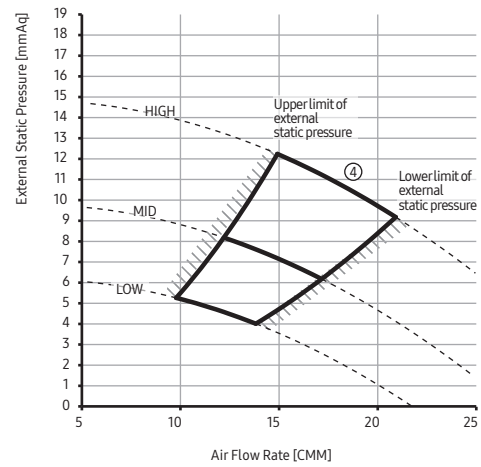

⑤	External Static Pressure(mmAq)	Option Code
	12 < SP ≤ 15	01B17C-1C59B3-27343C-374000

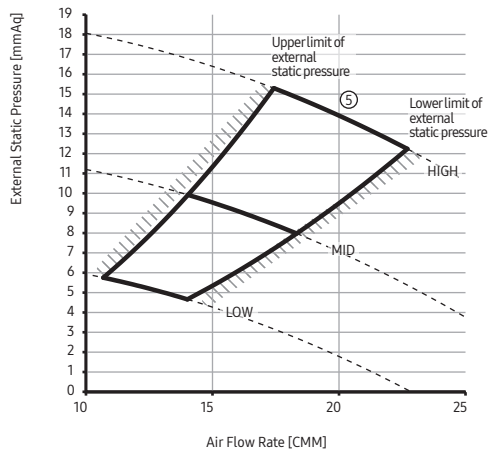

8. Fan Characteristics

MSP Duct

3) AC071RNMDKG/EU

①	External Static Pressure(mmAq)	Option Code
	0< SP ≤3	01B17C-1C5436-274750-376000

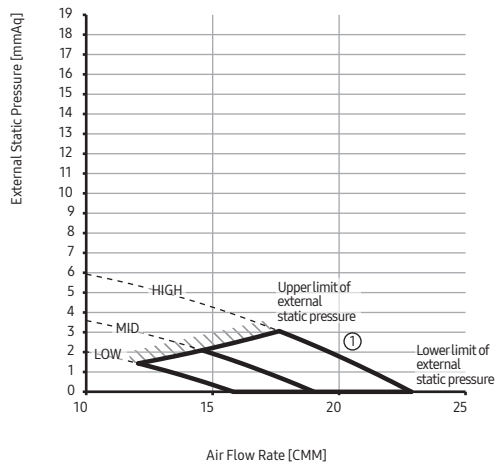

②	External Static Pressure(mmAq)	Option Code
	3< SP ≤6	01B17C-1C54AB-274750-376000

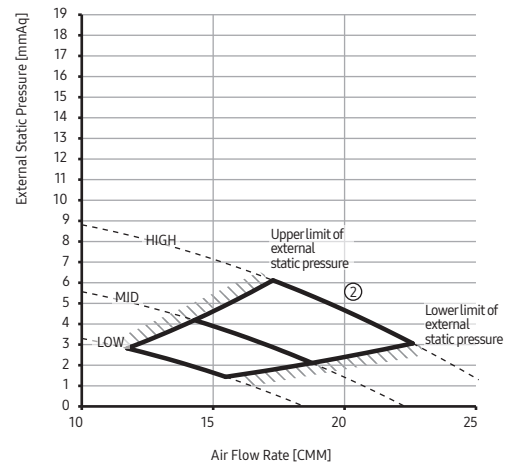

③	External Static Pressure(mmAq)	Option Code
	6< SP ≤9	01B17C-1C581E-274750-376000

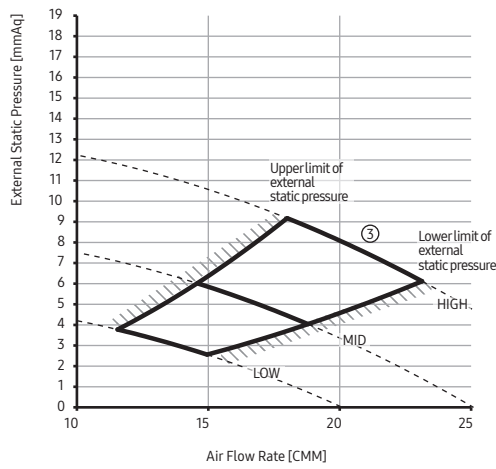

④	External Static Pressure(mmAq)	Option Code
	9< SP ≤12	01B17C-1C5972-274750-376000

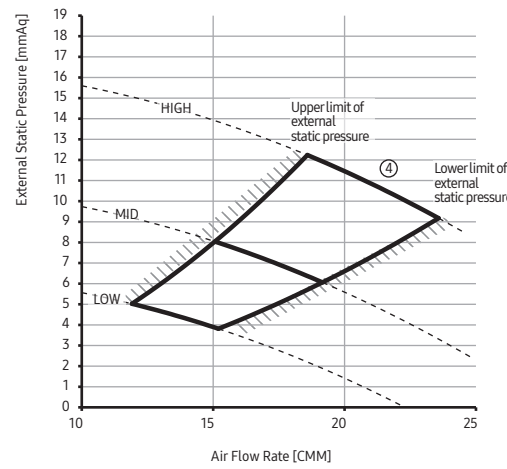

8. Fan Characteristics

MSP Duct

⑤	External Static Pressure(mmAq)	Option Code
	12< SP ≤15	01B17C-1C59C8-274750-376000

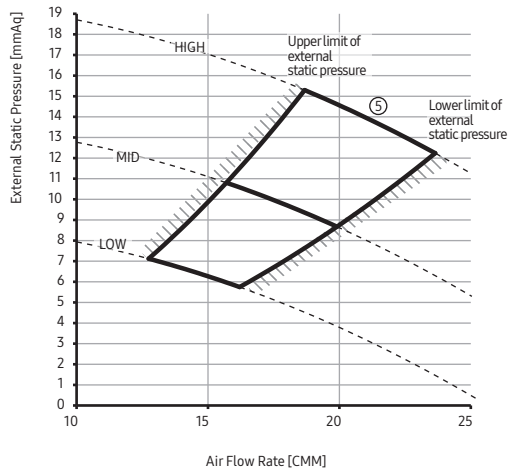

NOTE

- Adjust option code according to the actual installation condition (external static pressure).
- The graphs display the available external static pressure range of installed indoor units. Therefore, they do not reflect the actual change of external static pressure and airflow rate according to adjusted airflow (High-Mid-Low) of installed indoor units.

Wall Mounted Type (A3050)

1. Specification	115
2. Summary Table	121
3. Capacity Table	122
4. Dimensional Drawing	126
5. Center of Gravity	129
6. Electrical Wiring Diagram	130
7. Sound Data	131
8. Temperature and air flow distribution	133

Features & Benefits

Wall Mount Type

Breathe easily with wall-mounted systems designed for all-day freshness

Samsung Wall Mount Type air conditioners have been designed from the ground up to be exceptionally efficient. With their stylish, innovative designs, these wall-mounted air conditioners optimize comfort with cool, clean, healthy freshness for everyday living.

Improved blade operation

Samsung's wide twin blade can open up to 90° for more effective cooling. The longer twin blade ensures that air reaches every corner of the room with greater control.

Superior dust filtration

A Full High Density (HD) filter creates cleaner air through enhanced filtration, reducing microscopic dust particles by up to 90 percent.

Cleaner, healthier air

Virus Doctor eliminates the harmful substances and viruses breeding in the atmosphere of living spaces, thus providing the highest level of indoor air quality. This smart solution creates a purified zone, eliminating the hazards of airborne allergens and controlling the active oxygen that contributes to disease, cancer and accelerated aging.

Good's sleep

Samsung's Wall Mount Type units feature Good'sleep mode for a comfortable bedroom climate perfectly tempered for a restful night. With automatic temperature and moisture adjustment, all three vital stages of sleep are protected from humidity and heat so users wake up fully rested and refreshed.

AR9000, 7000, 5000 Series - Triangular design, powerful cooling

Cool every corner of the room with a unique, efficiency-boosting design

Samsung AR9000, 7000, 5000 Series units are designed with efficiency in mind. Their uniquely triangular design improves performance to circulate cool, clean air throughout every inch of the room. In addition, their smart design includes easy-to-remove filters for easy management and healthier airflow.

Faster, farther cooling performance

The units' distinctive triangular design has a wider intake, so more air can be drawn in. The improved width and angle of the outlet, extra v-blades and bigger fan also ensure that air is cooled and expelled faster and farther. The result is refreshingly cool air that reaches every corner of the room—with no blind spots. Their Smart Inverter also provides significantly greater energy efficiency.

Easy-access maintenance

Unlike conventional filters that are often difficult to access, the Samsung wall-mounted unit filter is on the outside, at the top of the device. Easy access means users can take out the filter, clean it and put it back without having to open a cover or pull hard to get it out. And its antibacterial coating filters dust, dangerous airborne contaminants and allergens for healthier breathing.



1. Specification

Wall Mounted Type (A3050)

Model Name	Indoor Unit			AC026RNADKG/EU	AC035RNADKG/EU	
	Outdoor Unit			AC026RXADKG/EU	AC035RXADKG/EU	
Mode				-	HEAT PUMP	
Performance	Capacity (Min/Std/Max)	Cooling	kW	0.96 / 2.60 / 3.60	1.00 / 3.50 / 3.90	
			Btu/h	3,280 / 8,870 / 12,280	3,410 / 11,940 / 13,300	
		Heating	kW	1.00 / 3.30 / 4.00	1.10 / 4.00 / 4.70	
			Btu/h	3,410 / 11,260 / 13,650	3,750 / 13,650 / 16,040	
Power	Power Input (Min/Std/Max)	Cooling	kW	0.18 / 0.74 / 1.20	0.19 / 1.10 / 1.30	
		Heating	kW	0.21 / 1.10 / 1.45	0.23 / 1.55 / 1.80	
	Current Input (Min/Std/Max)	Cooling	A	1.4 / 3.7 / 5.5	1.4 / 5.3 / 6.0	
		Heating	A	1.3 / 5.1 / 7.0	1.4 / 6.9 / 10.5	
	Current	MCA	A	11.6	11.6	
		MFA	A	12.8	12.8	
Efficiency	EER	Cooling	-	3.51	3.18	
	COP	Heating	-	3.00	2.58	
	SEER (Cooling Energy Grade)		-	6.6 (A++)	6.5 (A++)	
	SCOP (Heating Energy Grade)		-	4.0 (A+)	4.0 (A+)	
	Pdesignh		kW	2.0	2.0	
Piping Connections	Liquid Pipe	Type		Flare connection	Flare connection	
		Φ, mm (inch)		6.35 (1/4)	6.35 (1/4)	
	Gas Pipe	Type		Flare connection	Flare connection	
		Φ, mm (inch)		9.52 (3/8)	9.52 (3/8)	
	Heat Insulation		-	Both liquid and gas pipes	Both liquid and gas pipes	
	Piping length (ODU-IDU)	Standard	m		5	5
			Max.		20	20
Elevation				15	15	
Chargeless				20	20	
Wiring connections	Communication	Min.	mm ²	0.75	0.75	
		Remark	-	F1, F2	F1, F2	
Refrigerant	Type		-	R32	R32	
	Factory Charging	kg		0.9	0.9	
		tCO ₂ e			0.61	0.61

1. Specification

Wall Mounted Type (A3050)

Model Name	Indoor Unit			AC026RNADKG/EU	AC035RNADKG/EU
	Outdoor Unit			AC026RXADKG/EU	AC035RXADKG/EU
Power Supply				Ø, #, V, Hz	1,2,220-240,50
Heat Exchanger	Type		-	F&T	F&T
	Material	Fin	-	Al	Al
		Tube	-	Cu	Cu
	Fin Treatment		-	Green Hydrophile	Green Hydrophile
Fan	Type		-	Crossflow Fan	Crossflow Fan
	Quantity		EA	1	1
	Air Flow Rate	Cooling (H/M/L)	m ³ /min	7.7 / 6.2 / 5.0	8.5 / 7.2 / 5.8
			l/s	128.3 / 103.3 / 83.3	141.6 / 120 / 96.6
		Heating (H/M/L)	m ³ /min	8.5 / 7.2 / 5.8	8.5 / 7.2 / 5.8
l/s			141.6 / 120 / 96.6	141.6 / 120 / 96.6	
Fan Motor	Type		-	BLDC	BLDC
	Output		W x n	27	27
Drain	Drain Pipe		Φ, mm	ID18mm Hose	ID18mm Hose
Sound	Sound Pressure Level	High/Mid/Low/(Silent)	dB(A)	36 / 30 / 24 / 21	38 / 32 / 26 / 20
	Sound Power Level		dB(A)	56	59
External Dimension	Net Weight		kg	7.6	7.6
	Shipping Weight		kg	9.0	9.0
	Net Dimensions (WxHxD)		mm	750 x 249 x 246	750 x 249 x 246
	Shipping Dimensions (WxHxD)		mm	800 x 298 x 302	800 x 298 x 302
Casing	Material		-	ABS	ABS
Control System	Infrared remote control		-	AR-EH03E (Included)	AR-EH03E (Included)
	Wired remote control		-	MWR-WE13N MWR-WG00*N	MWR-WE13N MWR-WG00*N
Drain Pump	Drain Pump		-	-	-
	Max. lifting Height / Displacement		mm / Liter / h	-	-
Additional Accessories	Drain Pump	External Model	-	-	-
		Internal Model	-	-	-
		Max. lifting Height / Displacement	mm / Liter / h	-	-
	Air Filter		-	Removable / Washable	Removable / Washable
Virus Doctor		-	Included	Included	

1. Specification

Wall Mounted Type (A3050)

	Indoor Unit			AC026RNADKG/EU	AC035RNADKG/EU
	Outdoor Unit			AC026RXADKG/EU	AC035RXADKG/EU
Power Supply			Ø, #, V, Hz	1, 2, 220-240, 50	1, 2, 220-240, 50
	Heat Exchanger	Type		-	Fin & Tube
Material		Fin	-	Al	Al
		Tube	-	Cu	Cu
Fin Treatment		-	Anti-Corrosion	Anti-Corrosion	
Compressor	Model Name			UB9AK5090FER	UB9AK5090FER
	Type		-	Single BLDC	Single BLDC
	Output		kW	0.86	0.86
	Oil	Type	-	POE	POE
Initial charge		cc	320	320	
Fan	Type		-	Propeller	Propeller
	Discharge direction		-	Front	Front
	Quantity		EA	1	1
	Air Flow Rate			m ³ /min	29
		l/s	483	500	
Fan Motor	Type		-	BLDC Motor	BLDC Motor
	Output		W x n	40 x 1	40 x 1
Sound	Sound Pressure Level	Cooling	dB(A)	46	48
		Heating	dB(A)	47	48
	Sound Power Level		dB(A)	59	61
External Dimension	Net Weight		kg	32.5	32.5
	Shipping Weight		kg	35.5	35.5
	Net Dimensions (WxHxD)		mm	790 x 548 x 285	790 x 548 x 285
	Shipping Dimensions (WxHxD)		mm	913 x 622 x 371	913 x 622 x 371
Casing	Material	Body	-	EGI Steel Plate	EGI Steel Plate
	Operating Temp. Range	Cooling	°C	-15 ~ 46	-15 ~ 46
Heating		°C	-20 ~ 24	-20 ~ 24	

NOTE

- Specification may be subject to change without prior notice.
- 1) Performances are based on the following test conditions.
 - Cooling : Indoor temperature 27°C DB, 19°C WB, Outdoor temperature 35°C DB, 24°C WB
 - Heating : Indoor temperature 20°C DB, 15°C WB, Outdoor temperature 7°C DB, 6°C WB
 - Equivalent refrigerant pipe length 5m, Level differences 0m
- 2) Select wire size based on the value of MCA
- 3) Sound pressure level is obtained in an anechoic room.
 - Sound pressure level is a relative value, depending on the distance and acoustic environment.
 - Sound pressure level may differ depending on operation condition.
 - dBA = A-weighted sound pressure level
 - Reference acoustic pressure 0 dB = 20uPa
- 4) Sound power level is an absolute value that a sound source generates.
 - dBA = A-weighted sound power level
 - Reference power : 1pW
 - Measured according to ISO 3741
- 5) These products contain R32(GWP=675) which is fluorinated greenhouse gas.
- 6) 'MWR-WG00*N' is new wired remote control type(Graphic).
If you need the latest control system information, please refer to SAC control TDB.

1. Specification

Wall Mounted Type (A3050)

Model Name	Indoor Unit			AC052RNADKG/EU	AC071RNADKG/EU
	Outdoor Unit			AC052RXADKG/EU	AC071RXADKG/EU
Mode				-	HEAT PUMP
Performance	Capacity (Min/Std/Max)	Cooling	kW	1.30 / 5.00 / 6.50	1.50 / 7.10 / 8.70
			Btu/h	4,430 / 17,060 / 22,180	5,120 / 24,230 / 29,690
		Heating	kW	1.50 / 6.00 / 6.25	1.90 / 8.00 / 9.00
			Btu/h	5,120 / 20,470 / 21,320	6,480 / 27,300 / 30,710
Power	Power Input (Min/Std/Max)	Cooling	kW	0.40 / 2.20 / 2.30	0.35 / 2.35 / 3.60
		Heating	kW	0.34 / 2.15 / 3.15	0.35 / 2.45 / 3.95
	Current Input (Min/Std/Max)	Cooling	A	2.6 / 9.6 / 10.1	2.0 / 10.3 / 16.0
		Heating	A	2.3 / 9.4 / 14.0	2.0 / 10.7 / 17.0
	Current	MCA	A	18.1	18.1
		MFA	A	20.6	20.6
Efficiency	EER	Cooling	-	2.27	3.02
	COP	Heating	-	2.79	3.27
	SEER (Cooling Energy Grade)		-	6.2 (A++)	6.4 (A++)
	SCOP (Heating Energy Grade)		-	3.9 (A)	4.0 (A+)
	Pdesignh		kW	2.4	3.6
Piping Connections	Liquid Pipe	Type		Flare connection	Flare connection
		Φ, mm (inch)		6.35 (1/4)	6.35 (1/4)
	Gas Pipe	Type		Flare connection	Flare connection
		Φ, mm (inch)		12.7 (1/2)	15.88 (5/8)
	Heat Insulation		-	Both liquid and gas pipes	Both liquid and gas pipes
	Piping length (ODU-IDU)	Standard	m	5	5
		Max.	m	30	50
Elevation		m	20	30	
Chargeless		m	10	15	
Wiring connections	Communication	Min.	mm ²	0.75	0.75
		Remark	-	F1, F2	F1, F2
Refrigerant	Type		-	R32	R32
	Factory Charging		kg	1.2	1.7
			tCO ₂ e	0.81	1.15

1. Specification

Wall Mounted Type (A3050)

Model Name	Indoor Unit		AC052RNADKG/EU	AC071RNADKG/EU	
	Outdoor Unit		AC052RXADKG/EU	AC071RXADKG/EU	
Power Supply		Ø, #, V, Hz	1,2,220-240,50	1,2,220-240,50	
Heat Exchanger	Type		-	F&T	
	Material	Fin	-	Al	
		Tube	-	Cu	
Fin Treatment		-	Green Hydrophile	Green Hydrophile	
Fan	Type		-	Crossflow Fan	
	Quantity		EA	1	
	Air Flow Rate	Cooling (H/M/L)	m ³ /min	10.7 / 9.0 / 7.2	17.1 / 14.5 / 12.4
			l/s	178.3 / 150 / 120	285 / 241.6 / 206.6
		Heating (H/M/L)	m ³ /min	10.7 / 9.0 / 7.2	17.1 / 14.5 / 12.4
l/s			178.3 / 150 / 120	285 / 241.6 / 206.6	
Fan Motor	Type		-	BLDC	
	Output		W x n	27	
Drain	Drain Pipe		Φ, mm	ID18mm Hose	
Sound	Sound Pressure Level	High/Mid/Low/(Silent)	dB(A)	42 / 37 / 32 / 25	
	Sound Power Level		dB(A)	60	
External Dimension	Net Weight		kg	10.8	
	Shipping Weight		kg	12.6	
	Net Dimensions (WxHxD)		mm	896 x 261 x 261	
	Shipping Dimensions (WxHxD)		mm	956 x 317 x 335	
Casing	Material		-	ABS	
Control System	Infrared remote control		-	AR-EH03E (Included)	
	Wired remote control		-	MWR-WE13N MWR-WG00*N	
Drain Pump	Drain Pump		-	-	
	Max. lifting Height / Displacement		mm / Liter / h	-	
Additional Accessories	Drain Pump	External Model	-	-	
		Internal Model	-	-	
	Drain Pump	Max. lifting Height / Displacement	mm / Liter / h	-	-
		Air Filter		-	Removable / Washable
Virus Doctor		-	Included	Included	

1. Specification

Wall Mounted Type (A3050)

Model Name	Indoor Unit			AC052RNADKG/EU	AC071RNADKG/EU
	Outdoor Unit			AC052RXADKG/EU	AC071RXADKG/EU
Power Supply			Ø, #, V, Hz	1, 2, 220-240, 50	1, 2, 220-240, 50
Heat Exchanger	Type		-	Fin & Tube	Fin & Tube
	Material	Fin	-	Al	Al
		Tube	-	Cu	Cu
Fin Treatment		-	Anti-Corrosion	Anti-Corrosion	
Compressor	Model Name			UB9TK3150FE4	UB4TN8200FE4
	Type		-	Twin BLDC	Twin BLDC
	Output		kW	1.51	1.89
	Oil	Type	-	POE	POE
Initial charge		cc	320	320	
Fan	Type		-	Propeller	Propeller
	Discharge direction		-	Front	Front
	Quantity		EA	1	1
	Air Flow Rate		m ³ /min	40	51
l/s			667	850	
Fan Motor	Type		-	BLDC Motor	BLDC Motor
	Output		W x n	125 x 1	125 x 1
Sound	Sound Pressure Level	Cooling	dB(A)	48	49
		Heating	dB(A)	48	51
	Sound Power Level		dB(A)	62	65
External Dimension	Net Weight		kg	43.5	51.5
	Shipping Weight		kg	46.5	55.0
	Net Dimensions (WxHxD)		mm	880 x 638 x 310	880 x 798 x 310
	Shipping Dimensions (WxHxD)		mm	1,023 x 742 x 413	1,023 x 896 x 413
Casing	Material	Body	-	EGL Steel Plate	EGL Steel Plate
	Operating Temp. Range		°C	-15 ~ 50	-15 ~ 50
	Heating		°C	-20 ~ 24	-20 ~ 24

NOTE

- Specification may be subject to change without prior notice.
 - 1) Performances are based on the following test conditions.
 - Cooling : Indoor temperature 27°C DB, 19°C WB, Outdoor temperature 35°C DB, 24°C WB
 - Heating : Indoor temperature 20°C DB, 15°C WB, Outdoor temperature 7°C DB, 6°C WB
 - Equivalent refrigerant pipe length 5m, Level differences 0m
 - 2) Select wire size based on the value of MCA
 - 3) Sound pressure level is obtained in an anechoic room.
 - Sound pressure level is a relative value, depending on the distance and acoustic environment.
 - Sound pressure level may differ depending on operation condition.
 - dBA = A-weighted sound pressure level
 - Reference acoustic pressure 0 dB = 20uPa
 - 4) Sound power level is an absolute value that a sound source generates.
 - dBA = A-weighted sound power level
 - Reference power : 1pW
 - Measured according to ISO 3741
 - 5) These products contain R32(GWP=675) which is fluorinated greenhouse gas.
 - 6) 'MWR-WG00*N' is new wired remote control type(Graphic).
If you need the latest control system information, please refer to SAC control TDB.

2. Summary Table

Wall Mounted Type (A3050)

Performance Characteristics

Model Code	Net Weight (kg)	Capacity			Fan Speed	Airflow (CMM)	Sound Pressure Level (dBA)	Sound Power Level (dBA)
			Cooling (kW)	Heating (kW)				
AC026RNADKG/EU	7.6	Max.	3.60	4.00	High	7.7	36	56
		Std.	2.60	3.30	Mid	6.2	30	
		Min.	0.96	1.00	Low	5.0	24	
AC035RNADKG/EU	7.6	Max.	3.90	4.70	High	8.5	38	59
		Std.	3.50	4.00	Mid	7.2	32	
		Min.	1.00	1.10	Low	5.8	26	
AC052RNADKG/EU	10.8	Max.	6.50	6.25	High	10.7	42	60
		Std.	5.00	6.00	Mid	9.0	37	
		Min.	1.30	1.50	Low	7.2	32	
AC071RNADKG/EU	14.4	Max.	8.70	9.00	High	17.1	43	61
		Std.	7.10	8.00	Mid	14.5	39	
		Min.	1.50	1.90	Low	12.4	35	

NOTE

- Sound data is based on cooling operation.

Electric Characteristics

Model		Outdoor Unit				Input Current (Amperes)				Power Supply	
Indoor Unit	Outdoor Unit	Rated	Voltage range			Outdoor Unit		Indoor Unit	Total	MCA(A)	MFA(A)
		Hz	Volts	Min.	Max.	Cooling	Heating				
AC026RNADKG/EU	AC026RXADKG/EU	50	220 to 240	198	264	10	10	1.6	11.6	11.6	12.8
AC035RNADKG/EU	AC035RXADKG/EU	50	220 to 240	198	264	10	10	1.6	11.6	11.6	12.8
AC052RNADKG/EU	AC052RXADKG/EU	50	220 to 240	198	264	16.5	16.5	1.6	18.1	18.1	20.6
AC071RNADKG/EU	AC071RXADKG/EU	50	220 to 240	198	264	16.5	16.5	1.6	18.1	18.1	20.6

NOTE

- MCA : Minimum circuit amperes
- MFA : Maximum fuse amperes
- Select wire size based on the value of MCA

3. Capacity Table

Wall Mounted Type (A3050)

(1) AC026RNADKG/EU+AC026RXADKG/EU

Cooling

TC : Total Capacity, SHC : Sensible Heat Capacity, PI : Power Input

Outdoor Temperature (°C, DB)	Indoor Temperature (°C, DB / WB)																				
	20 / 14			22 / 16			25 / 18			27 / 19			28 / 20			30 / 22			32 / 24		
	TC	SHC	PI	TC	SHC	PI	TC	SHC	PI	TC	SHC	PI	TC	SHC	PI	TC	SHC	PI	TC	SHC	PI
	kW	kW	kW	kW	kW	kW	kW	kW	kW	kW	kW	kW	kW	kW	kW	kW	kW	kW	kW	kW	kW
-15	2.5	1.9	0.53	2.7	2.0	0.54	2.8	2.0	0.55	2.9	2.1	0.56	2.9	2.1	0.57	3.1	2.1	0.57	3.2	2.0	0.59
21	2.4	1.8	0.56	2.5	1.9	0.57	2.6	1.9	0.58	2.7	2.0	0.59	2.8	2.0	0.60	2.9	2.0	0.60	3.1	1.9	0.62
35	2.3	1.7	0.70	2.4	1.8	0.71	2.5	1.8	0.73	2.6	1.9	0.74	2.7	1.9	0.75	2.8	1.9	0.75	2.9	1.8	0.77
46	2.0	1.6	0.63	2.1	1.7	0.64	2.1	1.7	0.65	2.2	1.8	0.67	2.3	1.8	0.67	2.4	1.7	0.68	2.5	1.7	0.69

Heating

TC : Total Capacity, PI : Power Input

Outdoor Temperature (°C, DB)	Indoor Temperature (°C, DB)											
	16		18		20		21		22		24	
	TC	PI	TC	PI	TC	PI	TC	PI	TC	PI	TC	PI
	kW	kW	kW	kW	kW	kW	kW	kW	kW	kW	kW	kW
-20	2.3	1.46	2.3	1.44	2.3	1.43	2.3	1.42	2.2	1.40	2.2	1.39
-15	2.9	1.68	2.9	1.67	2.9	1.65	2.8	1.63	2.8	1.62	2.8	1.60
-5	3.3	1.57	3.3	1.56	3.2	1.54	3.2	1.52	3.2	1.51	3.1	1.49
0	3.4	1.35	3.4	1.33	3.4	1.32	3.3	1.31	3.3	1.29	3.3	1.28
7	3.4	1.12	3.3	1.11	3.3	1.10	3.3	1.09	3.2	1.08	3.2	1.07
24	4.4	1.29	4.3	1.28	4.3	1.27	4.2	1.25	4.2	1.24	4.2	1.23

NOTE

- The performance table shows the average value of each conditions.

3. Capacity Table

Wall Mounted Type (A3050)

(2) AC035RNADKG/EU+AC035RXADKG/EU

Cooling

TC : Total Capacity, SHC : Sensible Heat Capacity, PI : Power Input

Outdoor Temperature (°C, DB)	Indoor Temperature (°C, DB / WB)																				
	20 / 14			22 / 16			25 / 18			27 / 19			28 / 20			30 / 22			32 / 24		
	TC	SHC	PI	TC	SHC	PI	TC	SHC	PI	TC	SHC	PI	TC	SHC	PI	TC	SHC	PI	TC	SHC	PI
	kW	kW	kW	kW	kW	kW	kW	kW	kW	kW	kW	kW	kW	kW	kW	kW	kW	kW	kW	kW	kW
-15	3.4	2.4	0.79	3.6	2.5	0.80	3.7	2.6	0.82	3.9	2.6	0.84	3.9	2.6	0.84	4.1	2.6	0.85	4.3	2.5	0.87
21	3.3	2.3	0.83	3.4	2.4	0.85	3.6	2.4	0.86	3.7	2.5	0.88	3.7	2.5	0.89	3.9	2.5	0.90	4.1	2.4	0.92
35	3.1	2.2	1.04	3.3	2.3	1.06	3.4	2.3	1.08	3.5	2.4	1.10	3.6	2.4	1.11	3.7	2.4	1.12	3.9	2.3	1.14
46	2.6	2.1	0.93	2.8	2.1	0.95	2.9	2.2	0.97	3.0	2.3	0.99	3.0	2.2	1.00	3.2	2.2	1.01	3.3	2.2	1.03
50	2.0	1.6	0.83	2.1	1.7	0.85	2.2	1.7	0.86	2.3	1.8	0.88	2.3	1.8	0.89	2.4	1.8	0.90	2.6	1.7	0.92

Heating

TC : Total Capacity, PI : Power Input

Outdoor Temperature (°C, DB)	Indoor Temperature (°C, DB)											
	16		18		20		21		22		24	
	TC	PI	TC	PI	TC	PI	TC	PI	TC	PI	TC	PI
	kW	kW	kW	kW	kW	kW	kW	kW	kW	kW	kW	kW
-20	2.8	2.06	2.8	2.04	2.8	2.02	2.7	1.99	2.7	1.97	2.7	1.96
-15	3.5	2.37	3.5	2.35	3.5	2.33	3.4	2.30	3.4	2.28	3.4	2.26
-5	4.0	2.21	4.0	2.19	3.9	2.17	3.9	2.15	3.8	2.13	3.8	2.11
0	4.2	1.90	4.1	1.88	4.1	1.86	4.0	1.84	4.0	1.82	4.0	1.80
7	4.1	1.58	4.0	1.57	4.0	1.55	4.0	1.53	3.9	1.52	3.9	1.50
24	5.3	1.82	5.3	1.80	5.2	1.78	5.1	1.76	5.1	1.75	5.0	1.73

NOTE

- The performance table shows the average value of each conditions.

3. Capacity Table

Wall Mounted Type (A3050)

(3) AC052RNADKG/EU+AC052RXADKG/EU

Cooling

TC : Total Capacity, SHC : Sensible Heat Capacity, PI : Power Input

Outdoor Temperature (°C, DB)	Indoor Temperature (°C, DB / WB)																				
	20 / 14			22 / 16			25 / 18			27 / 19			28 / 20			30 / 22			32 / 24		
	TC	SHC	PI	TC	SHC	PI	TC	SHC	PI	TC	SHC	PI	TC	SHC	PI	TC	SHC	PI	TC	SHC	PI
	kW	kW	kW	kW	kW	kW	kW	kW	kW	kW	kW	kW	kW	kW	kW	kW	kW	kW	kW	kW	kW
-15	4.9	3.4	1.57	5.1	3.5	1.61	5.3	3.6	1.64	5.5	3.7	1.67	5.6	3.7	1.69	5.9	3.7	1.71	6.2	3.6	1.74
21	4.6	3.3	1.66	4.9	3.4	1.69	5.1	3.5	1.72	5.3	3.6	1.76	5.4	3.5	1.78	5.6	3.5	1.80	5.9	3.4	1.83
35	4.4	3.1	2.07	4.7	3.2	2.11	4.9	3.3	2.16	5.0	3.4	2.20	5.1	3.4	2.22	5.4	3.3	2.24	5.6	3.3	2.29
46	3.8	2.9	1.86	4.0	3.0	1.90	4.1	3.1	1.94	4.3	3.2	1.98	4.3	3.2	2.00	4.6	3.1	2.02	4.8	3.1	2.06
50	2.9	2.3	1.66	3.0	2.4	1.69	3.2	2.5	1.72	3.3	2.5	1.76	3.3	2.5	1.78	3.5	2.5	1.80	3.7	2.4	1.83

Heating

TC : Total Capacity, PI : Power Input

Outdoor Temperature (°C, DB)	Indoor Temperature (°C, DB)											
	16		18		20		21		22		24	
	TC	PI	TC	PI	TC	PI	TC	PI	TC	PI	TC	PI
	kW	kW	kW	kW	kW	kW	kW	kW	kW	kW	kW	kW
-20	4.2	2.85	4.2	2.82	4.1	2.80	4.1	2.77	4.1	2.74	4.0	2.71
-15	5.3	3.29	5.3	3.26	5.2	3.23	5.2	3.19	5.1	3.16	5.1	3.13
-5	6.0	3.07	5.9	3.04	5.9	3.01	5.8	2.98	5.8	2.95	5.7	2.92
0	6.2	2.63	6.2	2.61	6.1	2.58	6.1	2.55	6.0	2.53	5.9	2.50
7	6.1	2.19	6.1	2.17	6.0	2.15	5.9	2.13	5.9	2.11	5.8	2.09
24	8.0	2.52	7.9	2.50	7.8	2.47	7.7	2.45	7.6	2.42	7.6	2.40

NOTE

- The performance table shows the average value of each conditions.

3. Capacity Table

Wall Mounted Type (A3050)

(4) AC071RNADKG/EU+AC071RXADKG/EU

Cooling

TC : Total Capacity, SHC : Sensible Heat Capacity, PI : Power Input

Outdoor Temperature (°C, DB)	Indoor Temperature (°C, DB / WB)																				
	20 / 14			22 / 16			25 / 18			27 / 19			28 / 20			30 / 22			32 / 24		
	TC	SHC	PI	TC	SHC	PI	TC	SHC	PI	TC	SHC	PI	TC	SHC	PI	TC	SHC	PI	TC	SHC	PI
	kW	kW	kW	kW	kW	kW	kW	kW	kW	kW	kW	kW	kW	kW	kW	kW	kW	kW	kW	kW	kW
-15	6.9	5.1	1.68	7.3	5.3	1.72	7.6	5.5	1.75	7.8	5.6	1.79	8.0	5.6	1.80	8.4	5.5	1.82	8.8	5.4	1.86
21	6.6	4.9	1.77	6.9	5.0	1.81	7.2	5.2	1.84	7.5	5.4	1.88	7.6	5.3	1.90	8.0	5.2	1.92	8.4	5.1	1.96
35	6.3	4.7	2.21	6.6	4.8	2.26	6.9	4.9	2.30	7.1	5.1	2.35	7.2	5.0	2.37	7.6	5.0	2.40	8.0	4.9	2.44
46	5.3	4.5	1.99	5.6	4.7	2.03	5.9	4.8	2.07	6.0	5.0	2.12	6.2	4.9	2.14	6.5	4.9	2.16	6.8	4.8	2.20
50	4.1	3.6	1.77	4.3	3.7	1.81	4.5	3.8	1.84	4.6	4.0	1.88	4.7	3.9	1.90	4.9	3.9	1.92	5.2	3.8	1.96

Heating

TC : Total Capacity, PI : Power Input

Outdoor Temperature (°C, DB)	Indoor Temperature (°C, DB)											
	16		18		20		21		22		24	
	TC	PI	TC	PI	TC	PI	TC	PI	TC	PI	TC	PI
	kW	kW	kW	kW	kW	kW	kW	kW	kW	kW	kW	kW
-20	5.6	3.25	5.6	3.22	5.5	3.19	5.5	3.15	5.4	3.12	5.4	3.09
-15	7.1	3.75	7.0	3.71	7.0	3.68	6.9	3.64	6.8	3.60	6.8	3.57
-5	8.0	3.50	7.9	3.46	7.8	3.43	7.8	3.40	7.7	3.36	7.6	3.33
0	8.3	3.00	8.2	2.97	8.2	2.94	8.1	2.91	8.0	2.88	7.9	2.85
7	8.2	2.50	8.1	2.47	8.0	2.45	7.9	2.43	7.8	2.40	7.8	2.38
24	10.6	2.87	10.5	2.85	10.4	2.82	10.3	2.79	10.2	2.76	10.1	2.73

NOTE

- The performance table shows the average value of each conditions.

4. Dimensional Drawing

Wall Mounted Type (A3050)

AC026/035RNADKG/EU

Units : mm [inches]

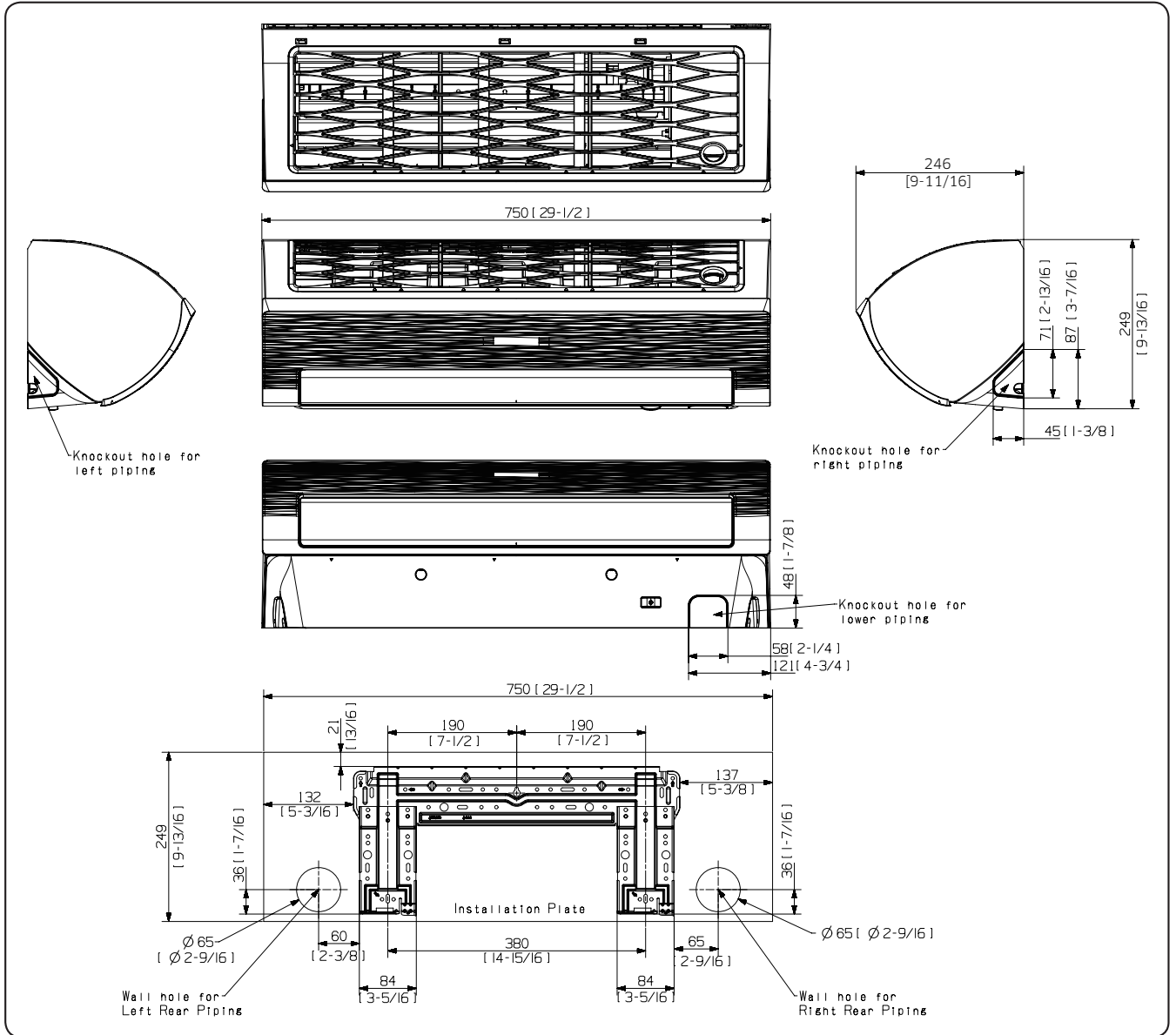

4. Dimensional Drawing

Wall Mounted Type (A3050)

AC052RNADKG/EU

Units : mm [inches]

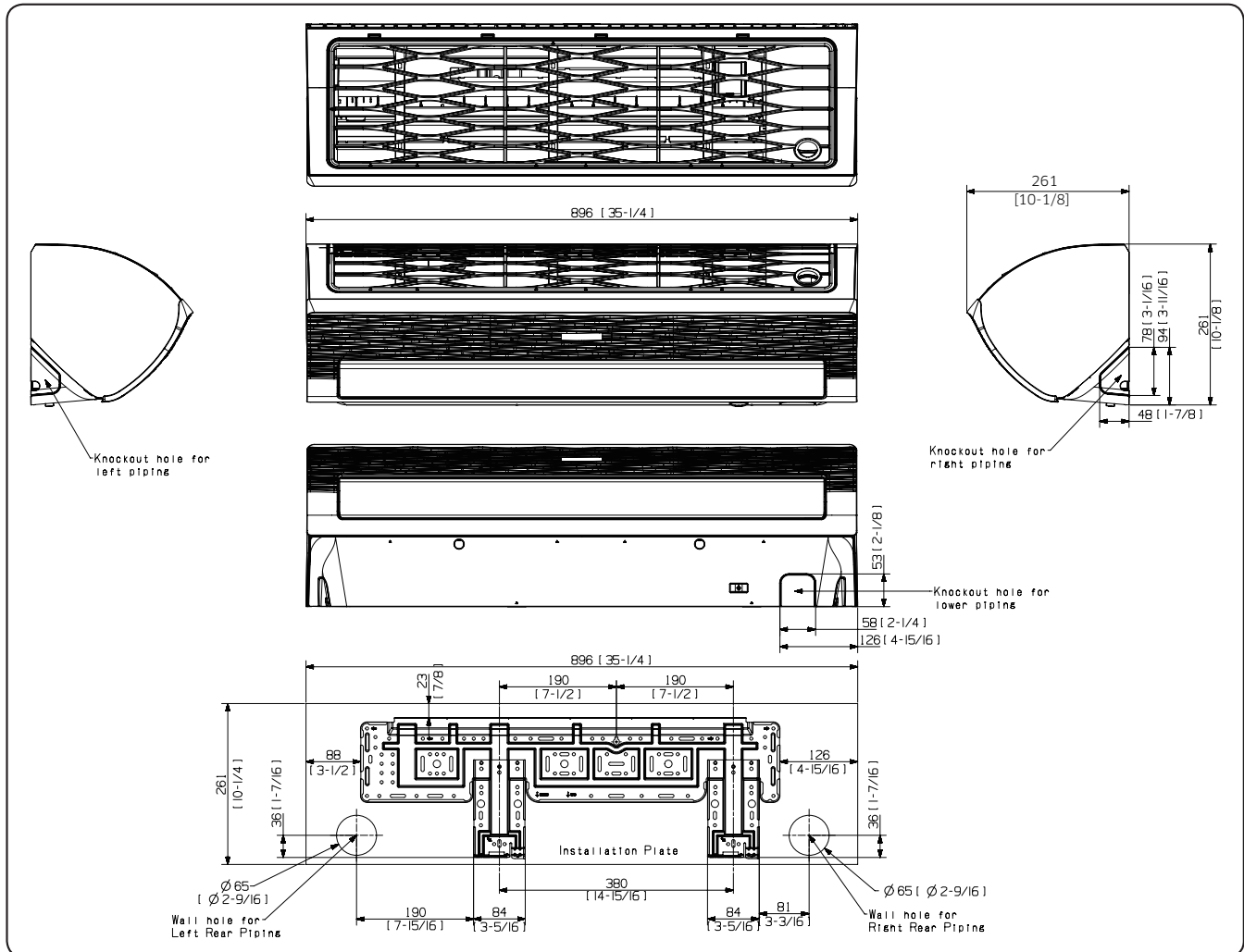

4. Dimensional Drawing

Wall Mounted Type (A3050)

AC071RNADKG/EU

Units : mm [inches]

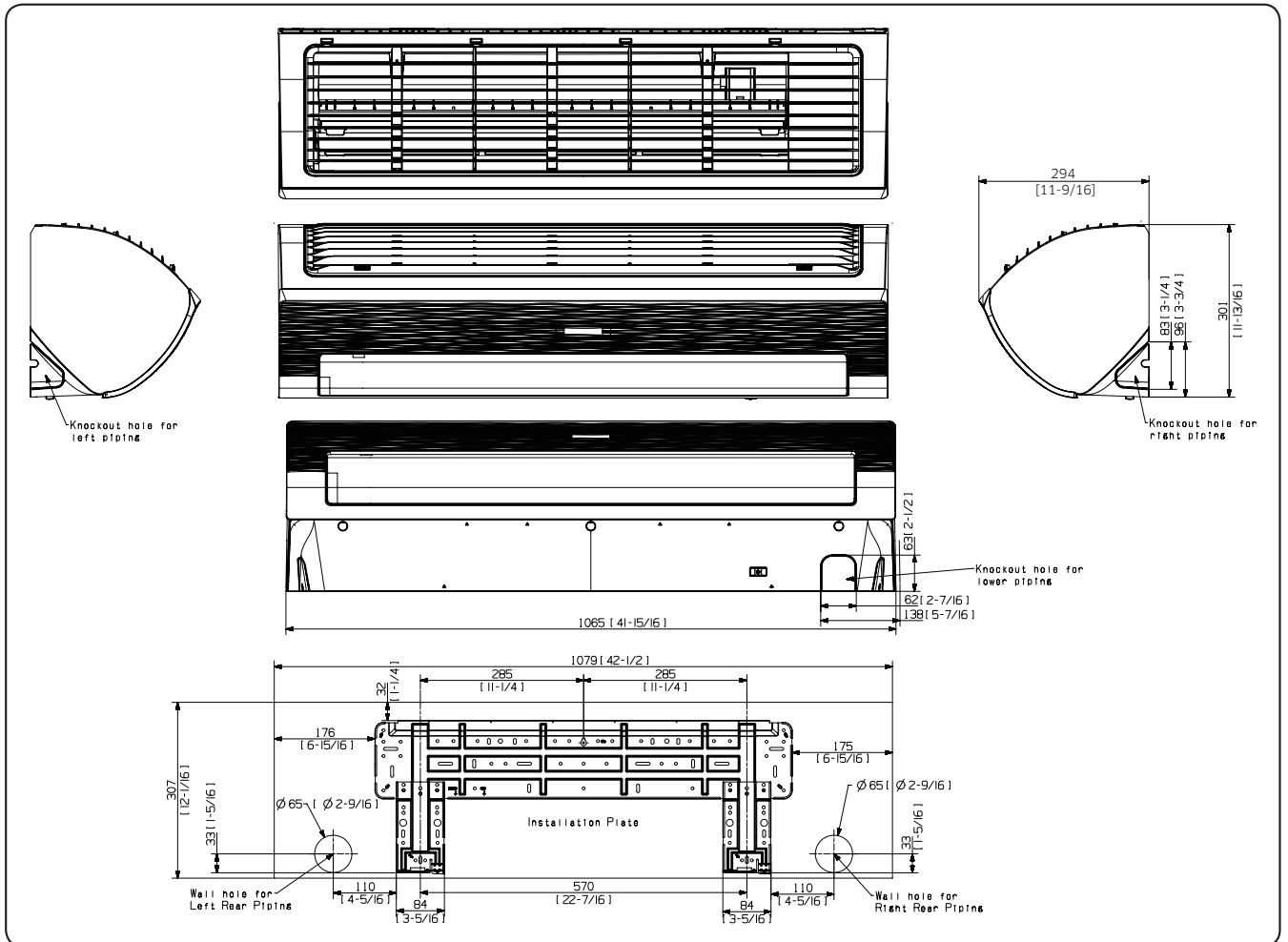

5. Center of Gravity

Wall Mounted Type (A3050)

AC026/035/052/071RNADKG/EU

Units : mm [inches]

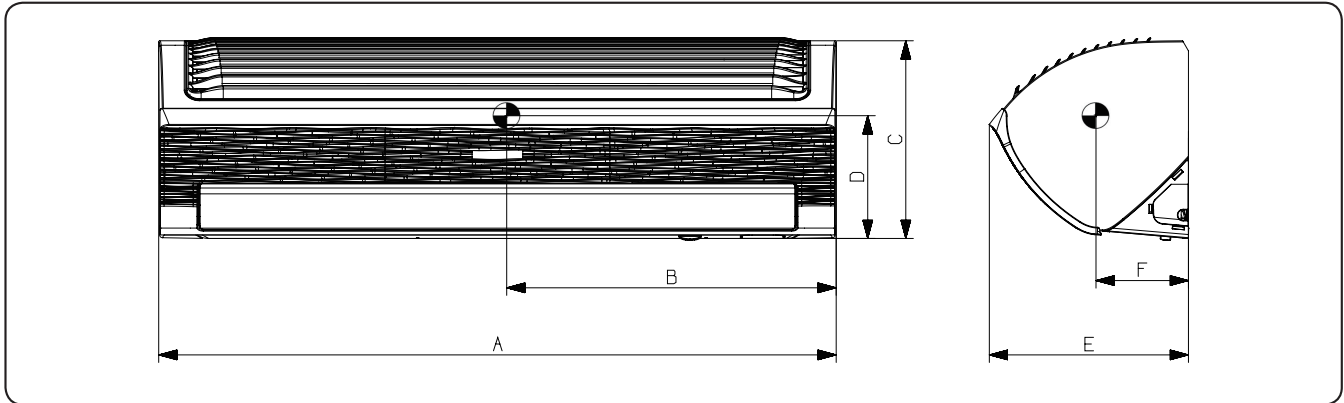

	A	B	C	D	E	F
~3.5kW	750 [29-1/2]	335 [13-3/16]	249 [9-13/16]	130 [5-1/8]	246 [9-11/16]	105 [4-1/8]
5.2kW	896 [35-1/4]	400 [15-3/4]	261 [10-1/4]	130 [5-1/8]	261 [10-1/8]	105 [4-1/8]
7.1kW	1065 [41-15/16]	470 [18-1/2]	307 [12-1/16]	130 [5-1/8]	300 [11-9/16]	105 [4-1/8]

6. Electrical Wiring Diagram

Wall Mounted Type (A3050)

AC026/035/052/071RNADKG/EU

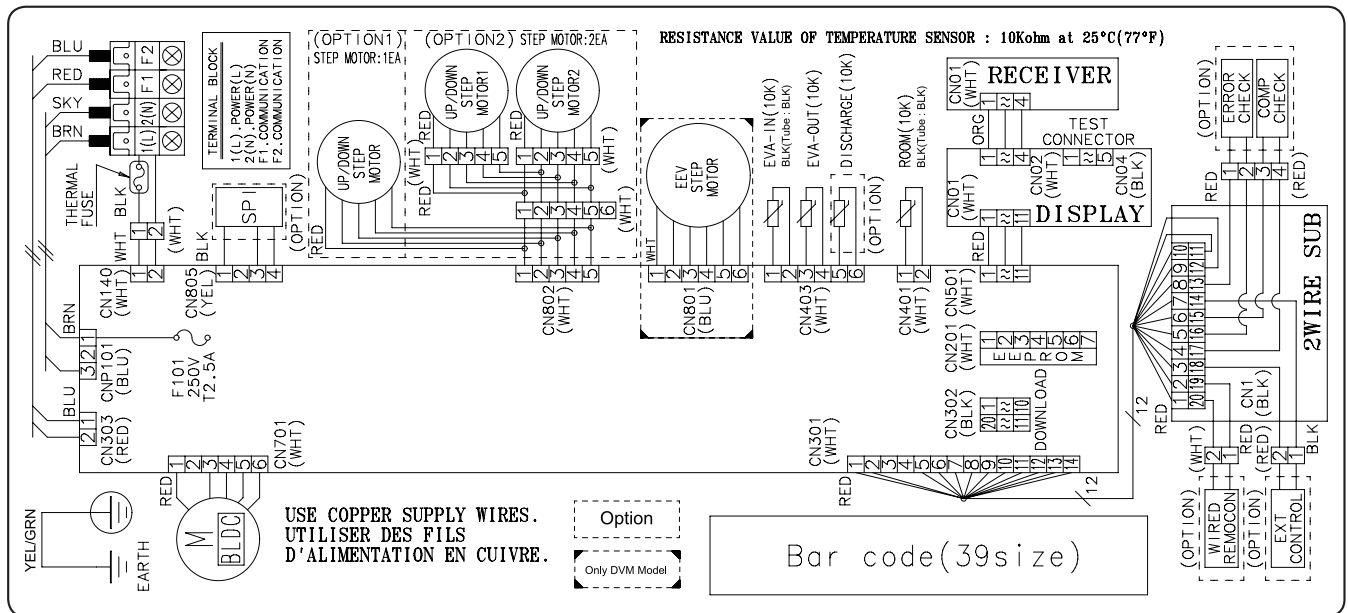

SPI	S-Plasma ion	EEV	Electronic Expansion Valve	ROOM	Thermistor ROOM in (10K)
M-BLDC	BLDC Motor	EVA-IN	Thermistor EVA IN(10K)	EVA-OUT	Thermistor EVA OUT(10K)

NOTE

- This wiring diagram applies only to the Indoor unit.
- Symbols show as follow :
blk: black, red: red, blu: blue, wht: white, yel: yellow, brn: brown, sky: skyblue: grn: green
- For connection wiring indoor-outdoor transmission F1-F2, indoor-wired remote controller transmission F3-F4.
- Protective earth(screw)

7. Sound Data

Wall Mounted Type (A3050)

Sound Pressure level

Unit: dB(A)

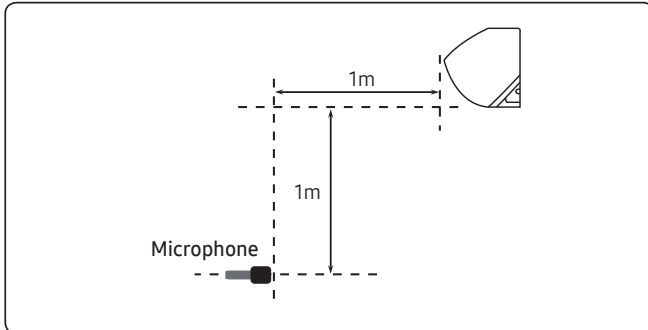

Model	HIGH	MID	LOW	SLIENT
AC026RNADKG/EU	36	30	24	21
AC035RNADKG/EU	38	32	26	20
AC052RNADKG/EU	42	37	32	25
AC071RNADKG/EU	43	40	35	30

- NR Curve

1) AC026RNADKG/EU

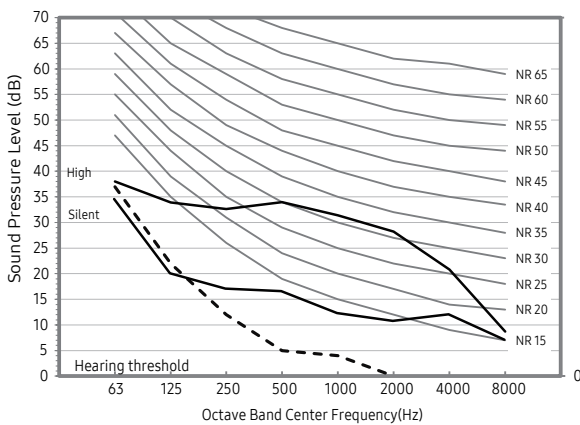

2) AC035RNADKG/EU

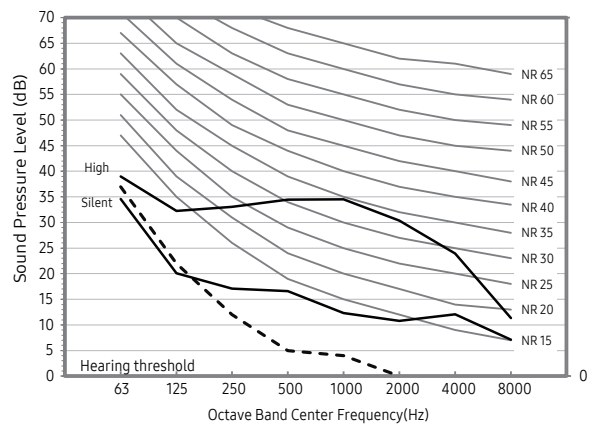

3) AC052RNADKG/EU

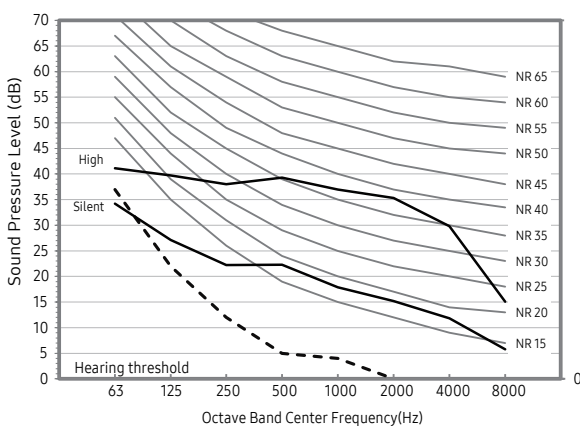

4) AC071RNADKG/EU

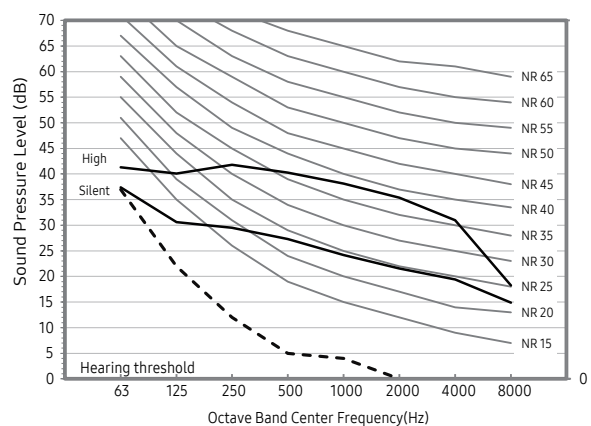

NOTE

- Specifications may be subject to change without prior notice.
 - Sound pressure level is obtained in an anechoic room.
 - Sound pressure level is a relative value, depending on the distance and acoustic environment.
 - Sound pressure level may differ depending on operation condition.
 - dBA = A weighted sound pressure level
 - Reference acoustic pressure 0 dB = 20μPa

6. Electrical Wiring Diagram

Wall Mounted Type (A3050)

Sound Power level

NOTE

Unit: dB(A)

- Specifications may be subject to change without prior notice
 - Sound power level is an absolute value that a sound source generates.
 - dBA = A-weighted sound power level.
 - Reference power : 1pW.
 - Measured according to ISO 3741.

Model	Power
AC026RNADKG/EU	56
AC035RNADKG/EU	59
AC052RNADKG/EU	60
AC071RNADKG/EU	61

• NR Curve

1) AC026RNADKG/EU

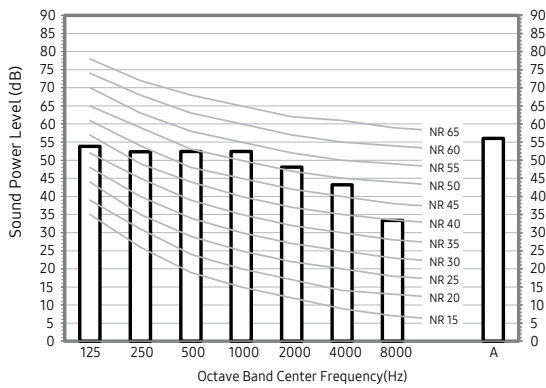

2) AC035RNADKG/EU

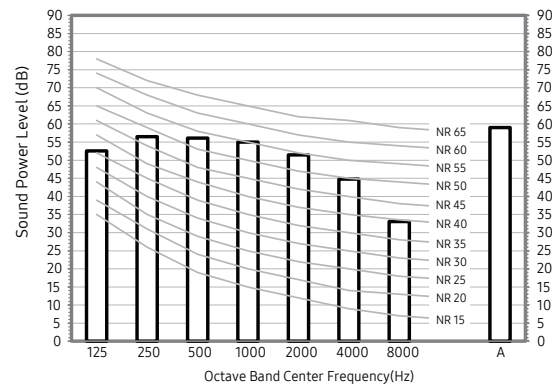

3) AC052RNADKG/EU

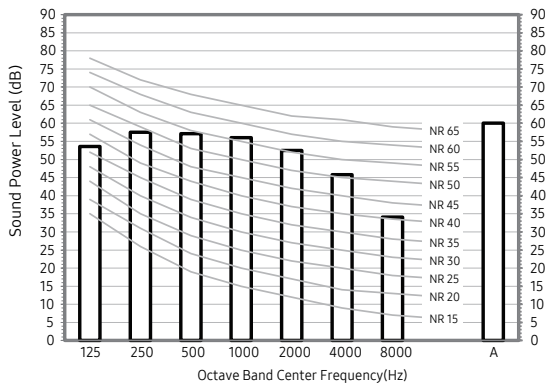

4) AC071RNADKG/EU

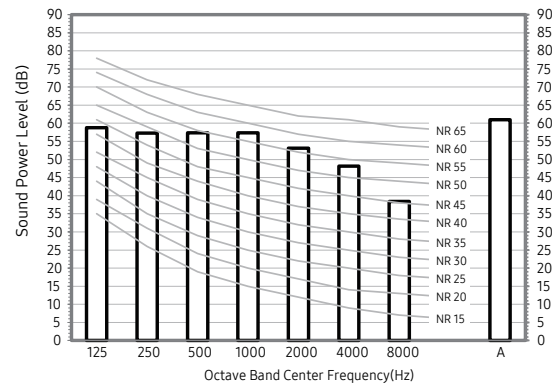

8. Temperature and air flow distribution

Wall Mounted Type (A3050)

AC026RNADKG/EU

- Cooling Air Velocity distribution
(Discharge angle : 23 degree)

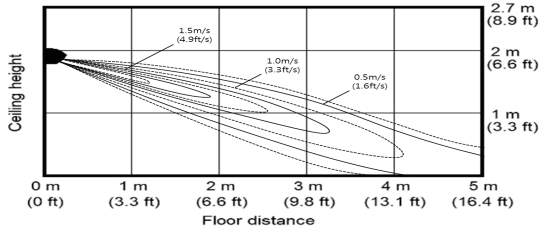

- Cooling temperature distribution
(Discharge angle : 23 degree)

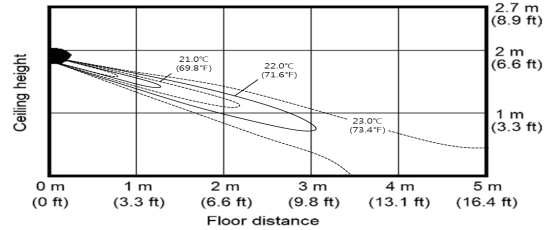

- Heating Air Velocity distribution
(Discharge angle : 53 degree)

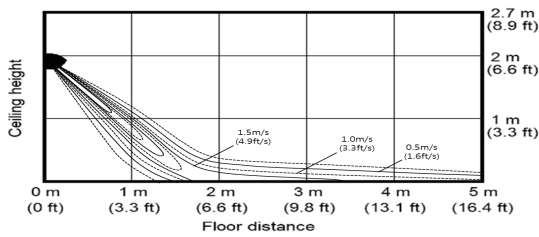

- Heating temperature distribution
(Discharge angle : 53 degree)

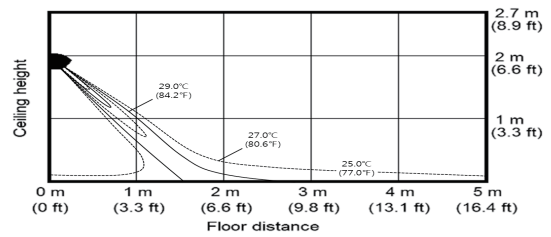

AC035RNADKG/EU

- Cooling Air Velocity distribution
(Discharge angle : 23 degree)

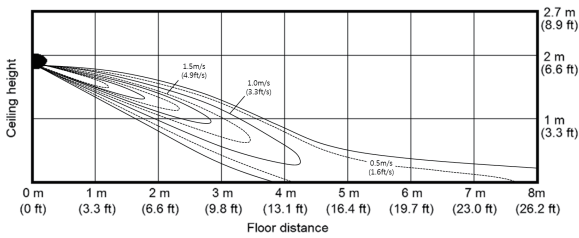

- Cooling temperature distribution
(Discharge angle : 23 degree)

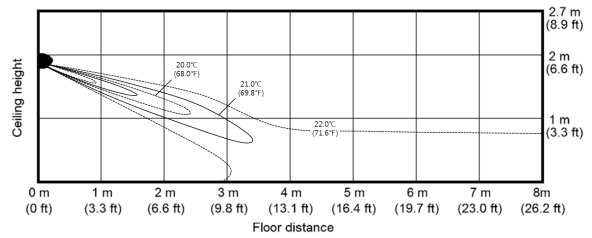

- Heating Air Velocity distribution
(Discharge angle : 53 degree)

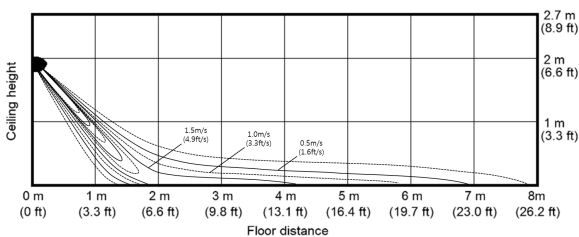

- Heating temperature distribution
(Discharge angle : 53 degree)

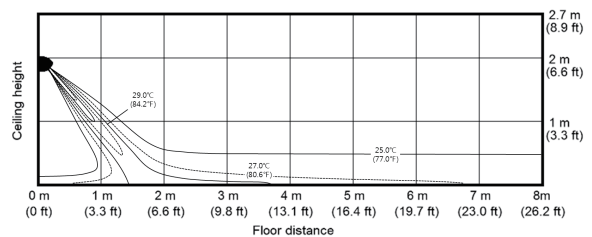

8. Temperature and air flow distribution

Wall Mounted Type (A3050)

AC052RNADKG/EU

- Cooling Air Velocity distribution

(Discharge angle : 16 degree)

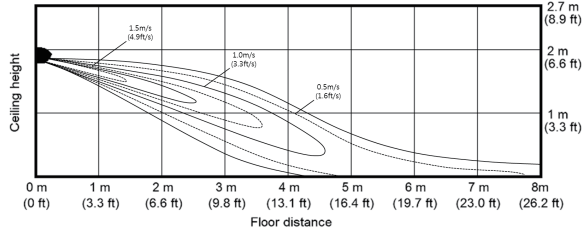

- Cooling temperature distribution

(Discharge angle : 16 degree)

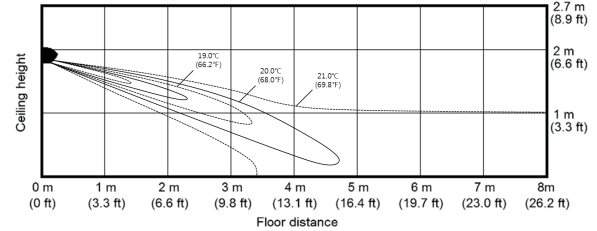

- Heating Air Velocity distribution

(Discharge angle : 46 degree)

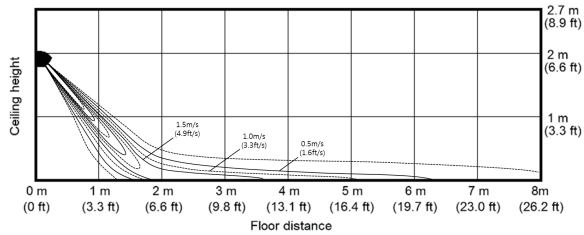

- Heating temperature distribution

(Discharge angle : 46 degree)

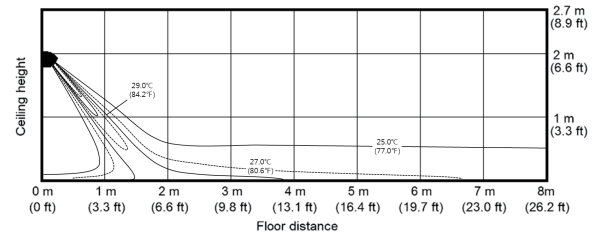

AC071RNADKG/EU

- Cooling Air Velocity distribution

(Discharge angle : 28 degree)

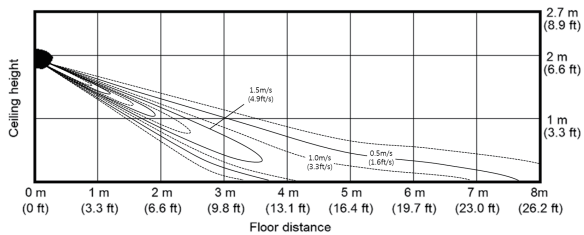

- Cooling temperature distribution

(Discharge angle : 28 degree)

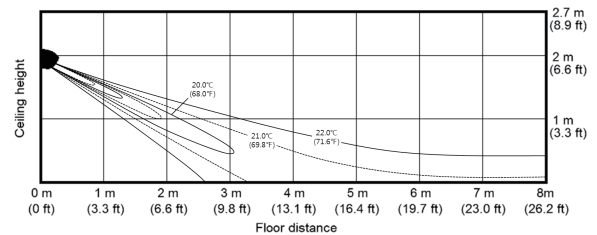

- Heating Air Velocity distribution

(Discharge angle : 58 degree)

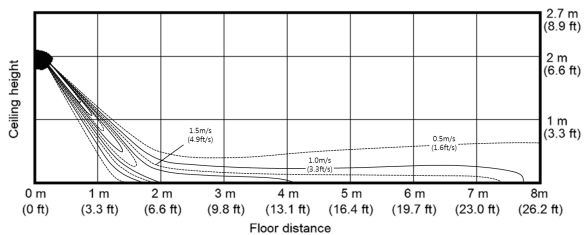

- Heating temperature distribution

(Discharge angle : 58 degree)

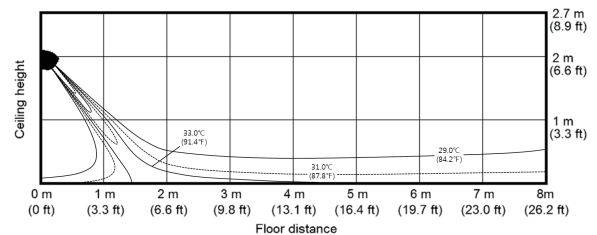

Ceiling

1. Specification	137
2. Summary Table	140
3. Capacity Table	141
4. Dimensional Drawing	143
5. Center of Gravity	144
6. Electrical Wiring Diagram	145
7. Sound Data	146
8. Temperature and air flow distribution	148

Features & Benefits

Ceiling Type - Slim yet functional design

Distribute refreshing airflow where needed with a compact, flexible design

Samsung's Ceiling Type indoor unit has 2-way installation options for the ceiling and floor, enabling more efficient use of available space. Users can enjoy crisp, powerful air throughout their entire space from the compact unit in the ceiling or floor.

Small package, big performance

The Samsung Ceiling Type air conditioner boasts a slim, compact design—half the size of conventional products—with cooling power comparable to larger units.

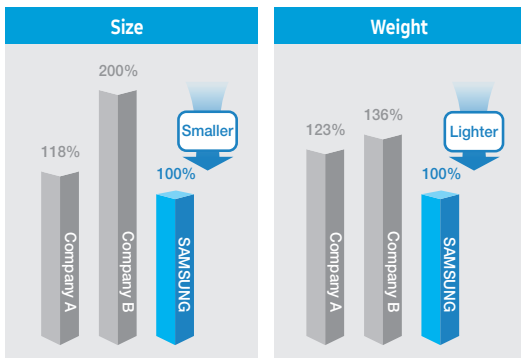

7.1kW Model

Choice of installation options

Depending on the available space and the purpose of the air conditioner, the indoor unit can be installed behind the ceiling or on the floor.



1. Specification

Ceiling

Model Name	Indoor Unit		AC052RNCDKG/EU	AC071RNCDKG/EU
	Outdoor Unit		AC052RXADKG/EU	AC071RXADKG/EU
Mode			-	HEAT PUMP
Performance	Capacity (Min/Std/Max)	Cooling	kW	1.20 / 5.00 / 6.50
			Btu/h	4,100 / 17,060 / 22,180
		Heating	kW	1.70 / 6.00 / 7.70
			Btu/h	5,800 / 20,470 / 26,270
Power	Power Input (Min/Std/Max)	Cooling	kW	0.48 / 1.58 / 1.90
		Heating	kW	0.43 / 1.92 / 3.05
	Current Input (Min/Std/Max)	Cooling	A	2.8 / 7.2 / 9.0
		Heating	A	2.4 / 8.5 / 14.5
	Current	MCA	A	17.5
		MFA	A	20.6
Efficiency	EER	Cooling	-	3.16
	COP	Heating	-	3.13
	SEER (Cooling Energy Grade)		-	6.4 (A++)
	SCOP (Heating Energy Grade)		-	3.9 (A)
	Pdesignh		kW	2.4
Piping Connections	Liquid Pipe		Type	Flare connection
			Φ, mm (inch)	6.35 (1/4)
	Gas Pipe		Type	Flare connection
			Φ, mm (inch)	12.7 (1/2)
	Heat Insulation		-	Both liquid and gas pipes
	Piping length (ODU-IDU)	Standard	m	5
		Max.	m	30
Elevation		m	20	
Chargeless		m	10	
Wiring connections	Communication	Min.	mm ²	0.75
		Remark	-	F1, F2
Refrigerant	Type		-	R32
	Factory Charging		kg	1.2
			tCO ₂ e	0.81

1. Specification

Ceiling

Model Name	Indoor Unit		AC052RNCDKG/EU	AC071RNCDKG/EU	
	Outdoor Unit		AC052RXADKG/EU	AC071RXADKG/EU	
Power Supply			Ø, #, V, Hz	1,2,220-240,50	
Heat Exchanger	Type		-	F&T	
	Material	Fin	-	Al	
		Tube	-	Cu	
	Fin Treatment		-	Green Hydrophile	
Fan	Type		-	Sirroco	
	Quantity		EA	2	
	Air Flow Rate	Cooling (H/M/L)	m ³ /min	12.6 / 11.3 / 10.0	
			l/s	210 / 188.3 / 166.6	
		Heating (H/M/L)	m ³ /min	12.6 / 11.3 / 10.0	
l/s			210 / 188.3 / 166.6		
Fan Motor	Type		-	BLDC	
	Output		W x n	40	
Drain	Drain Pipe		Φ, mm	ID18mm Hose	
Sound	Sound Pressure Level	High/Mid/Low/(Silent)	dB(A)	41 / 39 / 36	
	Sound Power Level		dB(A)	60	
External Dimension	Net Weight		kg	20.0	
	Shipping Weight		kg	25.0	
	Net Dimensions (WxHxD)		mm	1,000 x 200 x 650	
	Shipping Dimensions (WxHxD)		mm	1,074 x 294 x 726	
Casing	Material		-	ABS	
Control System	Infrared remote control		-	AR-EH03E (Included)	
	Wired remote control		-	MWR-WE13N MWR-WG00*N	
Drain Pump	Drain Pump		-	-	
	Max. lifting Height / Displacement		mm / Liter / h	-	
Additional Accessories	Drain Pump	External Model	-	-	
		Internal Model	-	-	
	Drain Pump	Max. lifting Height / Displacement	mm / Liter / h	-	-
		Air Filter		-	Removable / Washable
Virus Doctor		-	-	-	

1. Specification

Ceiling

Model Name	Indoor Unit			AC052RNCDKG/EU	AC071RNCDKG/EU
	Outdoor Unit			AC052RXADKG/EU	AC071RXADKG/EU
Power Supply		Ø, #, V, Hz		1, 2, 220-240, 50	1, 2, 220-240, 50
Heat Exchanger	Type		-	Fin & Tube	Fin & Tube
	Material	Fin	-	Al	Al
		Tube	-	Cu	Cu
	Fin Treatment		-	Anti-Corrosion	Anti-Corrosion
Compressor	Model Name		-	UB9TK3150FE4	UB4TN8200FE4
	Type		-	Twin BLDC	Twin BLDC
	Output		kW	1.51	1.89
	Oil	Type	-	POE	POE
		Initial charge	cc	320	320
Fan	Type		-	Propeller	Propeller
	Discharge direction		-	Front	Front
	Quantity		EA	1	1
	Air Flow Rate		m ³ /min	40	51
			l/s	667	850
Fan Motor	Type		-	BLDC Motor	BLDC Motor
	Output		W x n	125 x 1	125 x 1
Sound	Sound Pressure Level	Cooling	dB(A)	48	49
		Heating	dB(A)	48	51
	Sound Power Level		dB(A)	62	65
External Dimension	Net Weight		kg	43.5	51.0
	Shipping Weight		kg	46.5	55.0
	Net Dimensions (WxHxD)		mm	880 x 638 x 310	880 x 798 x 310
	Shipping Dimensions (WxHxD)		mm	1,023 x 742 x 413	1,023 x 896 x 413
Casing	Material	Body	-	EGI Steel Plate	EGI Steel Plate
	Operating Temp. Range		°C	-15 ~ 50	-15 ~ 50
			°C	-20 ~ 24	-20 ~ 24

NOTE

- Specification may be subject to change without prior notice.
 - 1) Performances are based on the following test conditions.
 - Cooling : Indoor temperature 27°C DB, 19°C WB, Outdoor temperature 35°C DB, 24°C WB
 - Heating : Indoor temperature 20°C DB, 15°C WB, Outdoor temperature 7°C DB, 6°C WB
 - Equivalent refrigerant pipe length 5m, Level differences 0m
 - 2) Select wire size based on the value of MCA
 - 3) Sound pressure level is obtained in an anechoic room.
 - Sound pressure level is a relative value, depending on the distance and acoustic environment.
 - Sound pressure level may differ depending on operation condition.
 - dBA = A-weighted sound pressure level
 - Reference acoustic pressure 0 dB = 20uPa
 - 4) Sound power level is an absolute value that a sound source generates.
 - dBA = A-weighted sound power level
 - Reference power : 1pW
 - Measured according to ISO 3741
 - 5) These products contain R32(GWP=675) which is fluorinated greenhouse gas.
 - 6) 'MWR-WG00*N' is new wired remote control type(Graphic).
If you need the latest control system information, please refer to SAC control TDB.

2. Summary Table

Ceiling

Performance Characteristics

Model Code	Net Weight (kg)	Capacity			Fan Speed	Airflow (Cooling/Heating) (CMM)	Sound Pressure Level (dBA)	Sound Power Level (dBA)
			Cooling (kW)	Heating (kW)				
AC052RNCDKG/EU	20.0	Max.	6.50	7.70	High	12.6	41	60
		Std.	5.00	6.00	Mid	11.3	39	
		Min.	1.20	1.70	Low	10.0	36	
AC071RNCDKG/EU	20.0	Max.	8.70	9.00	High	15.2	46	64
		Std.	7.10	8.00	Mid	14.1	44	
		Min.	1.50	1.90	Low	13.1	42	

NOTE

- Sound data is based on cooling operation.

Electric Characteristics

Model		Outdoor Unit				Input Current (Amperes)				Power Supply	
Indoor Unit	Outdoor Unit	Rated Hz	Voltage range			Outdoor Unit		Indoor Unit	Total	MCA(A)	MFA(A)
			Volts	Min.	Max.	Cooling	Heating				
AC052RNCDKG/EU	AC052RXADKG/EU	50	220 to 240	198	264	16.5	16.5	1.0	17.5	17.5	20.6
AC071RNCDKG/EU	AC071RXADKG/EU	50	220 to 240	198	264	16.5	16.5	1.0	17.5	17.5	20.6

NOTE

- MCA : Minimum circuit amperes
- MFA : Maximum fuse amperes
- Select wire size based on the value of MCA

3. Capacity Table

Ceiling

(1) AC052RNCDKG/EU+AC052RXADKG/EU

Cooling

TC : Total Capacity, SHC : Sensible Heat Capacity, PI : Power Input

Outdoor Temperature (°C, DB)	Indoor Temperature (°C, DB / WB)																				
	20 / 14			22 / 16			25 / 18			27 / 19			28 / 20			30 / 22			32 / 24		
	TC	SHC	PI	TC	SHC	PI	TC	SHC	PI	TC	SHC	PI	TC	SHC	PI	TC	SHC	PI	TC	SHC	PI
	kW	kW	kW	kW	kW	kW	kW	kW	kW	kW	kW	kW	kW	kW	kW	kW	kW	kW	kW	kW	kW
-15	4.9	3.6	1.13	5.1	3.7	1.15	5.3	3.8	1.18	5.5	4.0	1.20	5.6	3.9	1.21	5.9	3.9	1.22	6.2	3.8	1.25
21	4.6	3.4	1.19	4.9	3.6	1.21	5.1	3.7	1.24	5.3	3.8	1.26	5.4	3.7	1.28	5.6	3.7	1.29	5.9	3.6	1.32
35	4.4	3.3	1.49	4.7	3.4	1.52	4.9	3.5	1.55	5.0	3.6	1.58	5.1	3.6	1.60	5.4	3.5	1.61	5.6	3.5	1.64
46	3.8	3.1	1.34	4.0	3.2	1.37	4.1	3.3	1.39	4.3	3.4	1.42	4.3	3.3	1.44	4.6	3.3	1.45	4.8	3.2	1.48
50	2.9	2.4	1.19	3.0	2.5	1.21	3.2	2.6	1.24	3.3	2.7	1.26	3.3	2.6	1.28	3.5	2.6	1.29	3.7	2.6	1.32

Heating

TC : Total Capacity, PI : Power Input

Outdoor Temperature (°C, DB)	Indoor Temperature (°C, DB)											
	16		18		20		21		22		24	
	TC	PI	TC	PI	TC	PI	TC	PI	TC	PI	TC	PI
	kW	kW	kW	kW	kW	kW	kW	kW	kW	kW	kW	kW
-20	4.2	2.55	4.2	2.52	4.1	2.50	4.1	2.47	4.1	2.45	4.0	2.42
-15	5.3	2.94	5.3	2.91	5.2	2.88	5.2	2.85	5.1	2.82	5.1	2.79
-5	6.0	2.74	5.9	2.71	5.9	2.69	5.8	2.66	5.8	2.63	5.7	2.61
0	6.2	2.35	6.2	2.33	6.1	2.30	6.1	2.28	6.0	2.26	5.9	2.24
7	6.1	1.96	6.1	1.94	6.0	1.92	5.9	1.90	5.9	1.88	5.8	1.86
24	8.0	2.25	7.9	2.23	7.8	2.21	7.7	2.19	7.6	2.16	7.6	2.14

NOTE

- The performance table shows the average value of each conditions.

2. Summary Table

Ceiling

(2) AC071RNCDKG/EU+AC071RXADKG/EU

Cooling

TC : Total Capacity, SHC : Sensible Heat Capacity, PI : Power Input

Outdoor Temperature (°C, DB)	Indoor Temperature (°C, DB / WB)																				
	20 / 14			22 / 16			25 / 18			27 / 19			28 / 20			30 / 22			32 / 24		
	TC	SHC	PI	TC	SHC	PI	TC	SHC	PI	TC	SHC	PI	TC	SHC	PI	TC	SHC	PI	TC	SHC	PI
	kW	kW	kW	kW	kW	kW	kW	kW	kW	kW	kW	kW	kW	kW	kW	kW	kW	kW	kW	kW	kW
-15	6.9	4.9	2.05	7.3	5.1	2.09	7.6	5.2	2.14	7.8	5.4	2.18	8.0	5.3	2.20	8.4	5.3	2.22	8.8	5.2	2.27
21	6.6	4.7	2.16	6.9	4.8	2.21	7.2	5.0	2.25	7.5	5.1	2.30	7.6	5.1	2.32	8.0	5.0	2.34	8.4	4.9	2.39
35	6.3	4.5	2.70	6.6	4.6	2.76	6.9	4.8	2.81	7.1	4.9	2.87	7.2	4.9	2.90	7.6	4.8	2.93	8.0	4.7	2.99
46	5.3	4.4	2.43	5.6	4.5	2.48	5.9	4.6	2.53	6.0	4.8	2.58	6.2	4.7	2.61	6.5	4.7	2.63	6.8	4.6	2.69
50	4.1	3.5	2.16	4.3	3.6	2.21	4.5	3.7	2.25	4.6	3.8	2.30	4.7	3.8	2.32	4.9	3.8	2.34	5.2	3.7	2.39

Heating

TC : Total Capacity, PI : Power Input

Outdoor Temperature (°C, DB)	Indoor Temperature (°C, DB)											
	16		18		20		21		22		24	
	TC	PI	TC	PI	TC	PI	TC	PI	TC	PI	TC	PI
	kW	kW	kW	kW	kW	kW	kW	kW	kW	kW	kW	kW
-20	5.6	4.04	5.6	4.00	5.5	3.97	5.5	3.93	5.4	3.89	5.4	3.85
-15	7.1	4.67	7.0	4.62	7.0	4.58	6.9	4.53	6.8	4.48	6.8	4.44
-5	8.0	4.36	7.9	4.31	7.8	4.27	7.8	4.23	7.7	4.19	7.6	4.14
0	8.3	3.73	8.2	3.70	8.2	3.66	8.1	3.62	8.0	3.59	7.9	3.55
7	8.2	3.11	8.1	3.08	8.0	3.05	7.9	3.02	7.8	2.99	7.8	2.96
24	10.6	3.58	10.5	3.54	10.4	3.51	10.3	3.47	10.2	3.44	10.1	3.40

NOTE

- The performance table shows the average value of each conditions.

4. Dimensional Drawing

Ceiling

AC052/071RNCDKG/EU

Units : mm [inches]

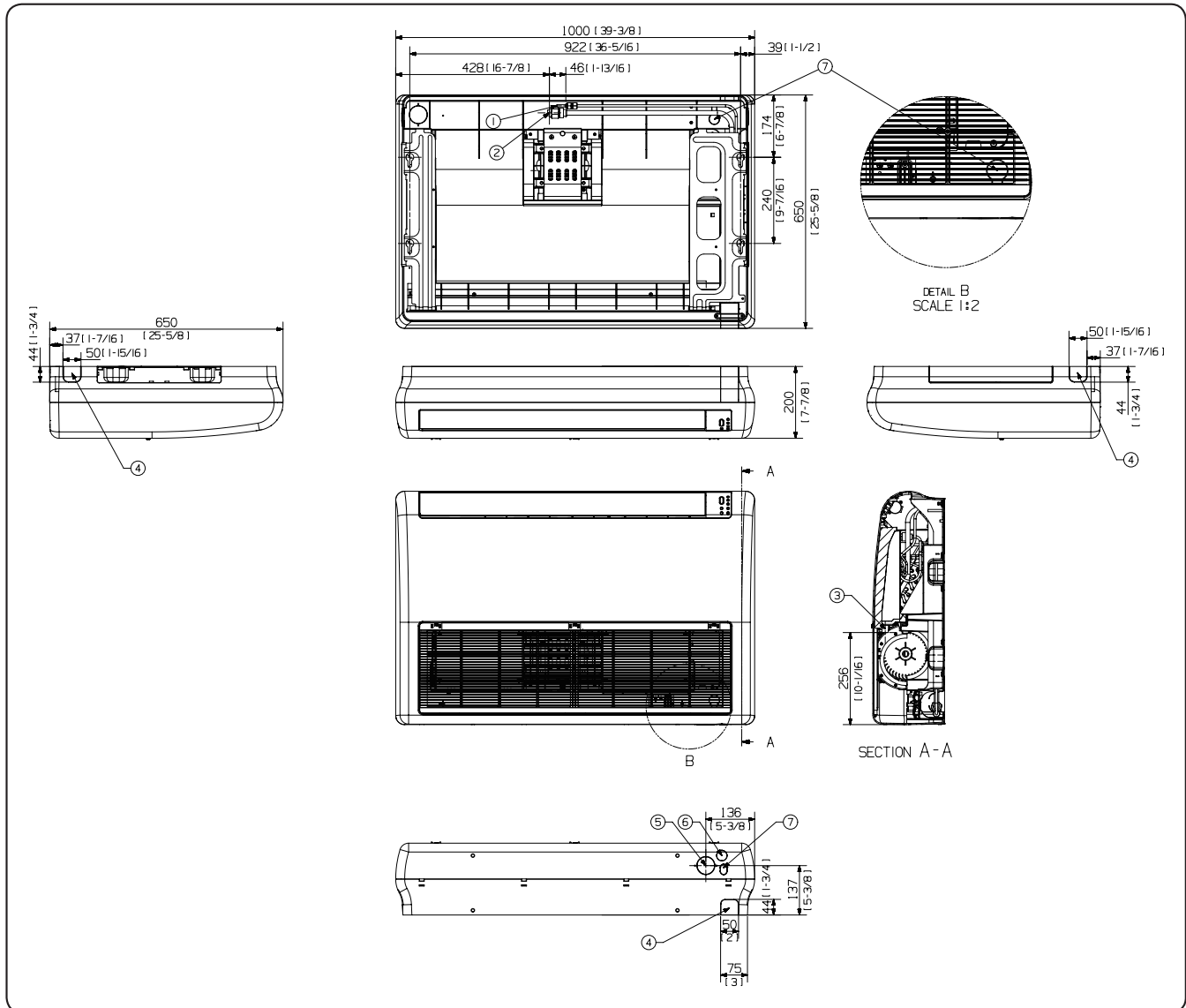

No.	Name	Description	
		AC052RNCDKG/EU	AC071RNCDKG/EU
1	Liquid pipe connection		Φ6.35(1/4)
2	Gas pipe connection	Φ12.7(1/2)	Φ15.88(5/8)
3	Drain pipe connection	ID18mm [11/16inch] Hose	
4	Knockout hole for piping		
6	Knockout hole for Fresh air intake	Φ50 [2]	
7	Knockout hole for drain hose		
8	Knockout hole for wiring		

NOTE

- As for suspension bolt, please use M8 ~ M10.
(Procured at local site)

5. Center of Gravity

Ceiling

AC052/071RNCDKG/EU

Units : mm [inches]

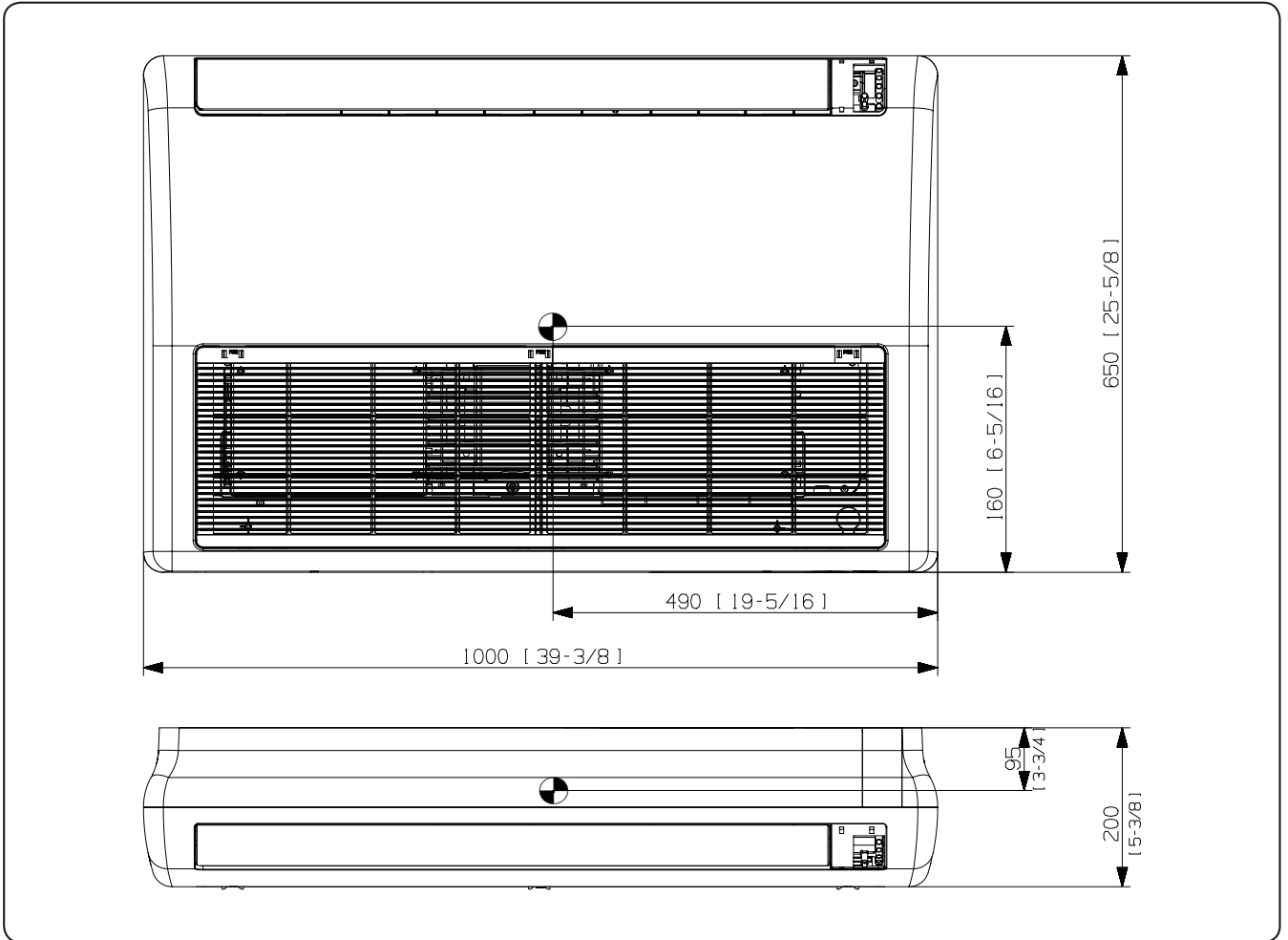

6. Electrical Wiring Diagram

Ceiling

AC052/071RNCDKG/EU

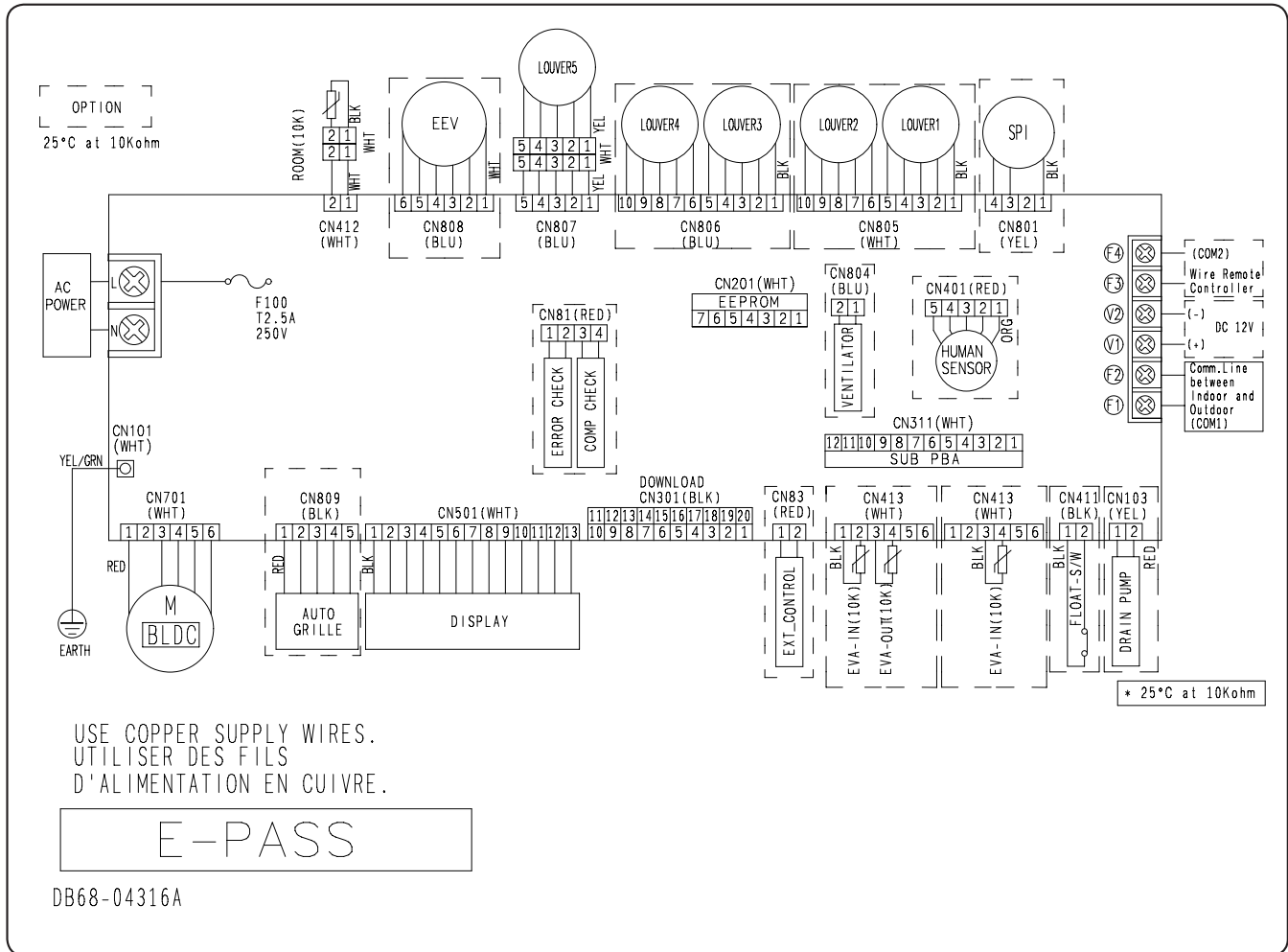

SPI	S-Plasma ion	EEV	Electronic Expansion Valve	ROOM	Thermistor ROOM in (10K)
FLOAT S/W	Switch of the float of Drain	EVA-IN	Thermistor EVA IN(10K)	EVA-OUT	Thermistor EVA OUT(10K)

NOTE

- This wiring diagram applies only to the Indoor unit.
- Symbols show as follow :
blk: black, red: red, blu: blue, wht: white, yel: yellow, brn: brown, sky: skyblue: grn: green
- For connection wiring indoor-outdoor transmission F1-F2, indoor-wired remote controller transmission F3-F4.
- Protective earth(screw)

7. Sound Data

Ceiling

Sound Pressure level

Unit: dB(A)

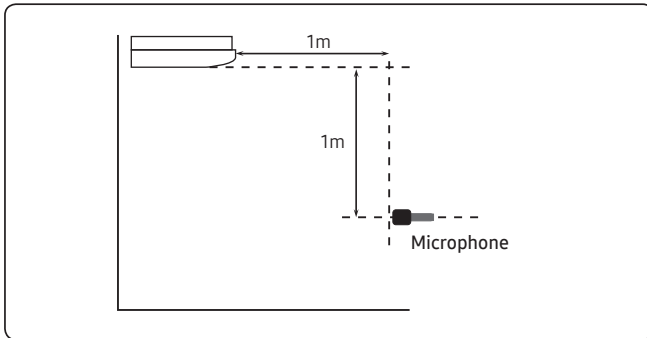

Model	HIGH	MID	LOW
AC052RNCDKG/EU	41	39	36
AC071RNCDKG/EU	46	44	42

- NR Curve

1) AC052RNCDKG/EU

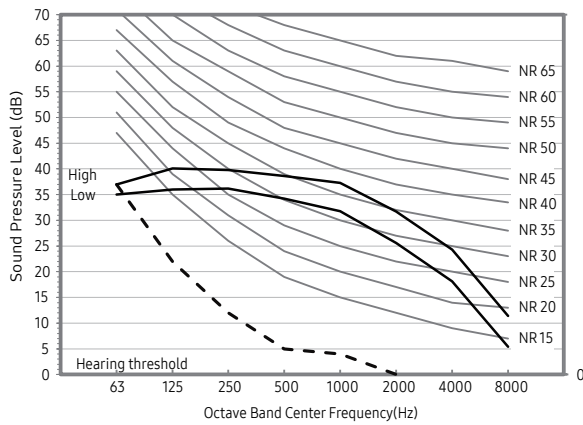

2) AC071RNCDKG/EU

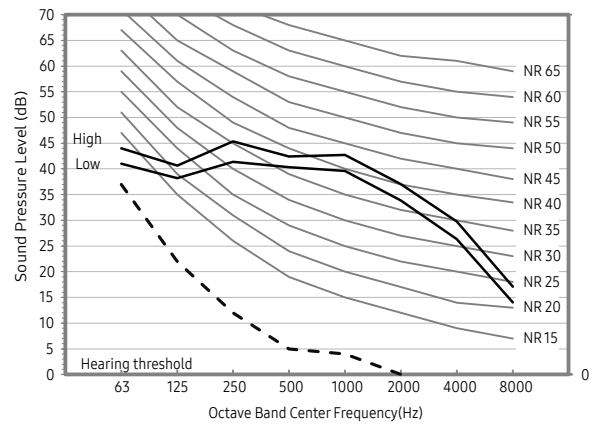

NOTE

- Specifications may be subject to change without prior notice.
 - Sound pressure level is obtained in an anechoic room.
 - Sound pressure level is a relative value, depending on the distance and acoustic environment.
 - Sound pressure level may differ depending on operation condition.
 - dB(A) = A weighted sound pressure level
 - Reference acoustic pressure 0 dB = 20μPa

7. Sound Data

Ceiling

Sound Power level

NOTE

Unit: dB(A)

- Specifications may be subject to change without prior notice
 - Sound power level is an absolute value that a sound source generates.
 - dBA = A-weighted sound power level.
 - Reference power : 1pW.
 - Measured according to ISO 3741.

Model	Power
AC052RNCDKG/EU	41
AC071RNCDKG/EU	46

• NR Curve

1) AC052RNCDKG/EU

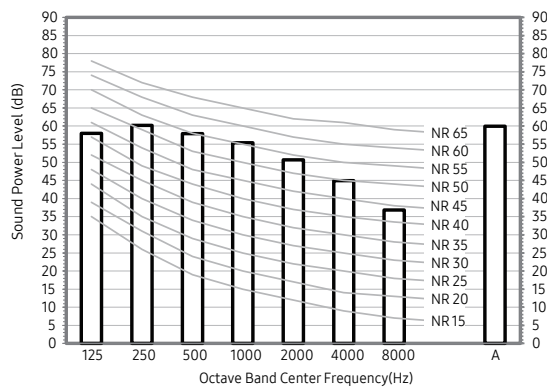

2) AC071RNCDKG/EU

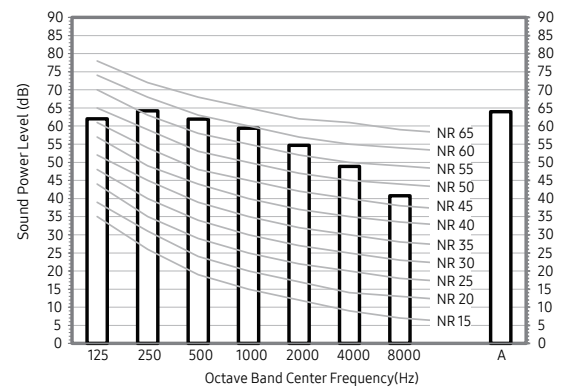

8. Temperature and air flow distribution

Ceiling (Ceiling Installation)

AC052RNCDKG/EU

- Cooling Air Velocity distribution

(Discharge angle : 50 degree)

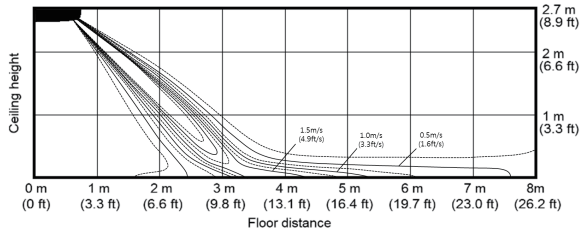

- Cooling temperature distribution

(Discharge angle : 50 degree)

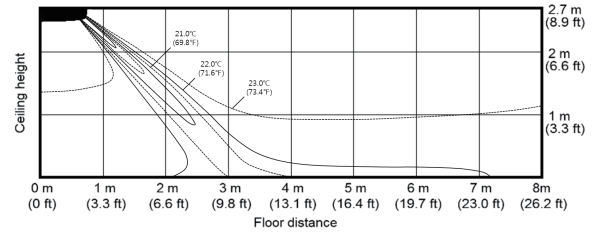

- Heating Air Velocity distribution

(Discharge angle : 40 degree)

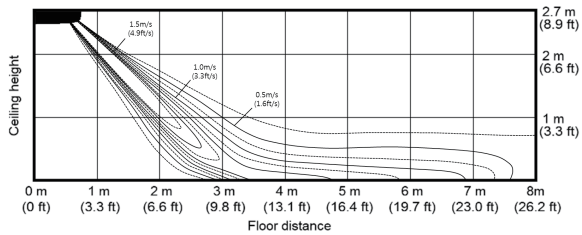

- Heating temperature distribution

(Discharge angle : 40 degree)

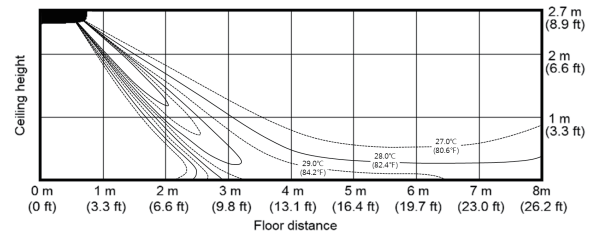

AC071RNCDKG/EU

- Cooling Air Velocity distribution

(Discharge angle : 50 degree)

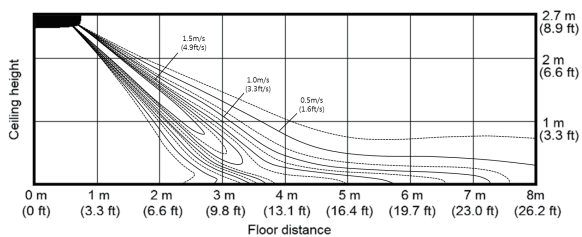

- Cooling temperature distribution

(Discharge angle : 50 degree)

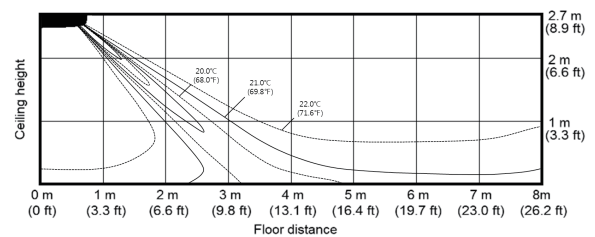

- Heating Air Velocity distribution

(Discharge angle : 40 degree)

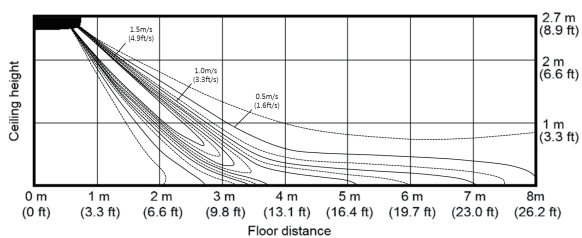

- Heating temperature distribution

(Discharge angle : 40 degree)

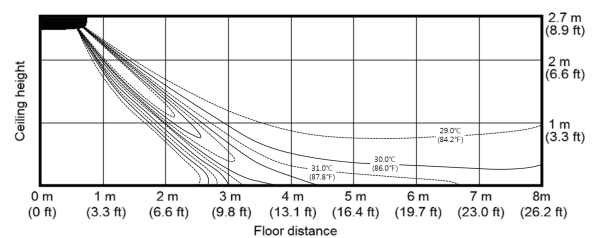

8. Temperature and air flow distribution

Ceiling (Floor Installation)

AC052RNCDKG/EU

- Cooling Air Velocity distribution

(Discharge angle : 50 degree)

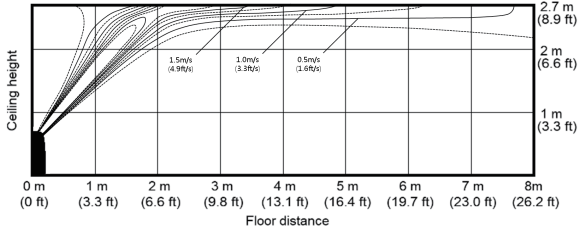

- Cooling temperature distribution

(Discharge angle : 50 degree)

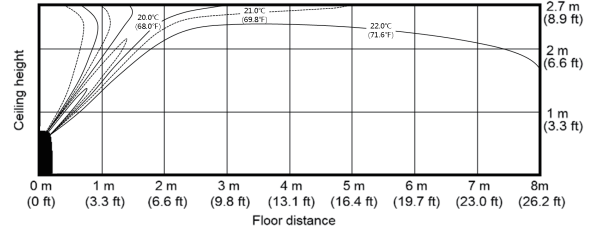

- Heating Air Velocity distribution

(Discharge angle : 40 degree)

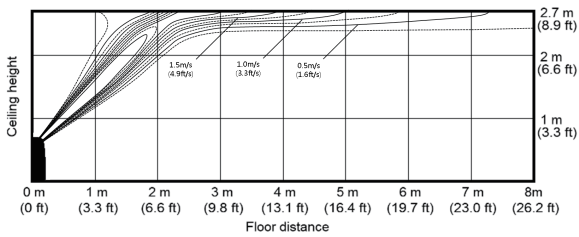

- Heating temperature distribution

(Discharge angle : 40 degree)

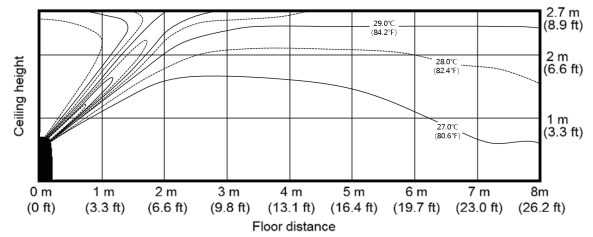

AC071RNCDKG/EU

- Cooling Air Velocity distribution

(Discharge angle : 50 degree)

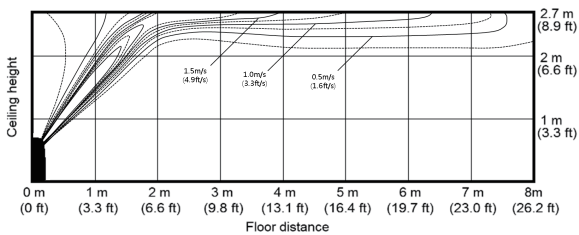

- Cooling temperature distribution

(Discharge angle : 50 degree)

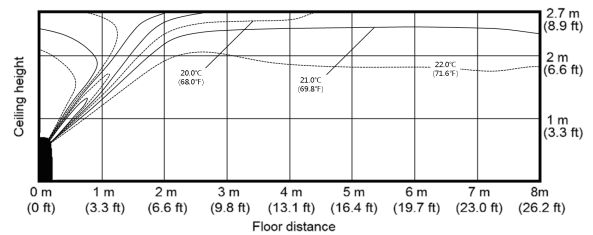

- Heating Air Velocity distribution

(Discharge angle : 40 degree)

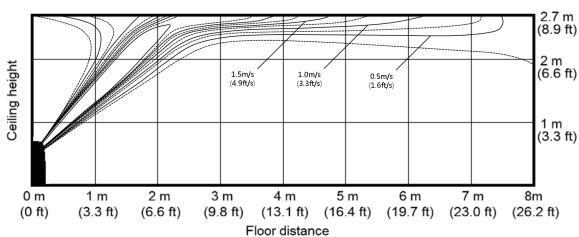

- Heating temperature distribution

(Discharge angle : 40 degree)

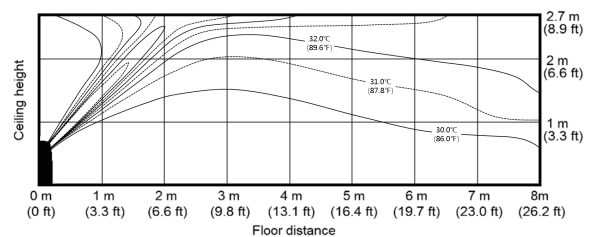

Outdoor Units

1. Summary Table	151
2. Dimensional Drawing	152
3. Center of Gravity	155
4. Electrical Wiring Diagram	157
5. Sound Data	159
6. Capacity Correction	161
7. Operation Range	164
8. Piping Diagram	165

1. Summary Table

Outdoor Units

Performance Characteristics

Capacity kW	Model Code	Net Size (WxHxD mm)	Net Weight (kg)	Airflow (CMM)	Sound Pressure Level (dBA)		Sound Power Level (dBA)
					Cooling	Heating	
2.6	AC026RXADKG/EU	790 x 548 x 285	32.8	29	46	47	59
3.5	AC035RXADKG/EU	790 x 548 x 285	32.8	30	48	48	61
5.2	AC052RXADKG/EU	880 x 638 x 310	43.8	40	48	48	62
7.1	AC071RXADKG/EU	880 x 798 x 310	53.0	51	49	51	65

NOTE

- Sound power level is based on cooling operation.

2. Dimensional Drawing

Outdoor Units

AC026/035RXADKG/EU

Units : mm [inches]

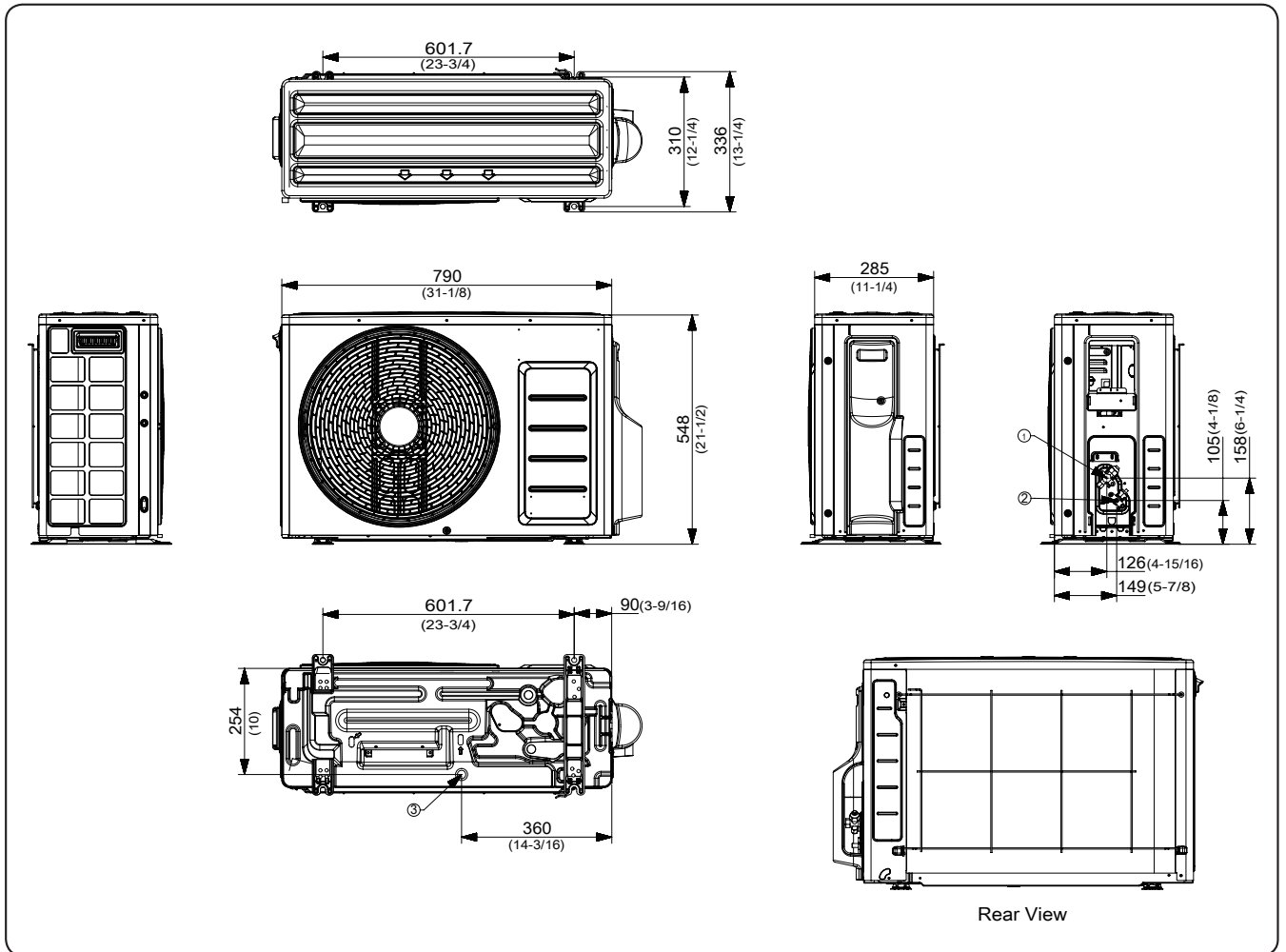

No.	Name	Description
1	Refrigerant gas pipe	Φ9.52(3/8)
2	Refrigerant liquid pipe	Φ6.35(1/4)
3	Drain Hole	Connection with the provided drain plug.

2. Dimensional Drawing

Outdoor Units

AC052RXADKG/EU

Units : mm [inches]

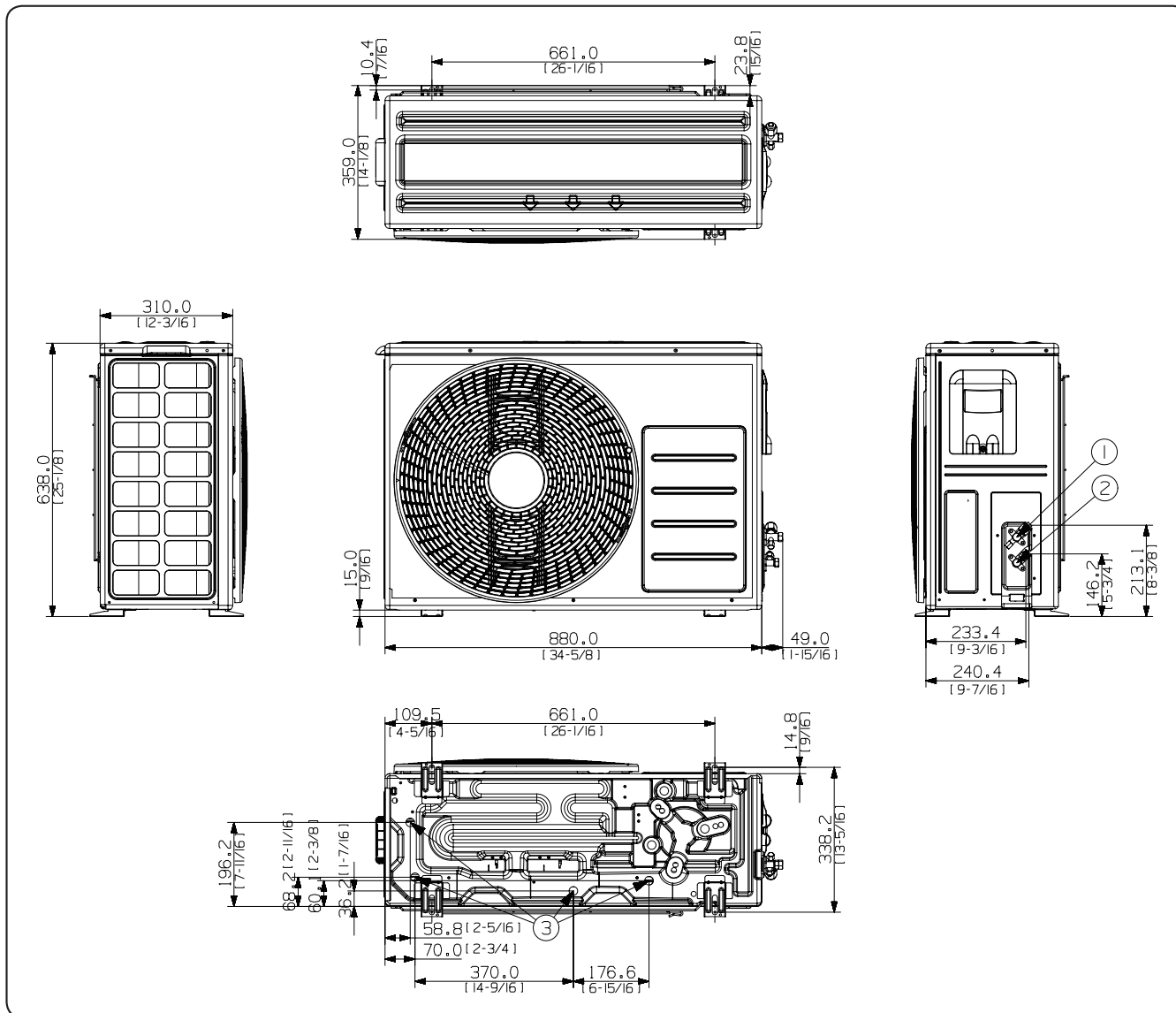

No.	Name	Description
1	Refrigerant gas pipe	Φ12.7(1/2)
2	Refrigerant liquid pipe	Φ6.35(1/4)
3	Drain Hole	Φ20

2. Dimensional Drawing

Outdoor Units

AC071RXADKG/EU

Units : mm [inches]

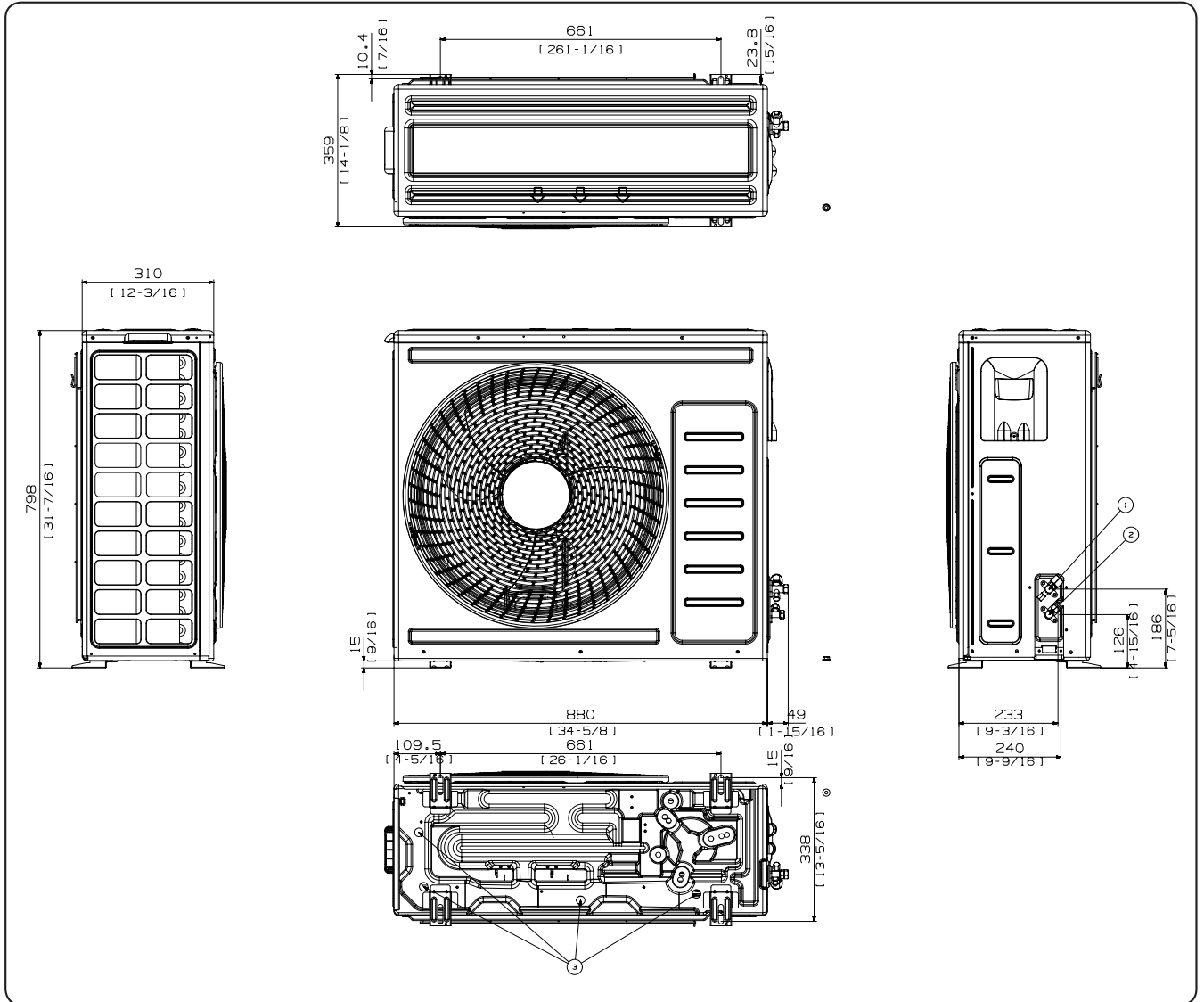

No.	Name	Description
1	Refrigerant gas pipe	Φ15.88(5/8)
2	Refrigerant liquid pipe	Φ6.35(1/4)
3	Drain Hole	Connection with the provided drain plug.

3. Center of Gravity

Outdoor Units

AC026/035RXADKG/EU

Units : mm [inches]

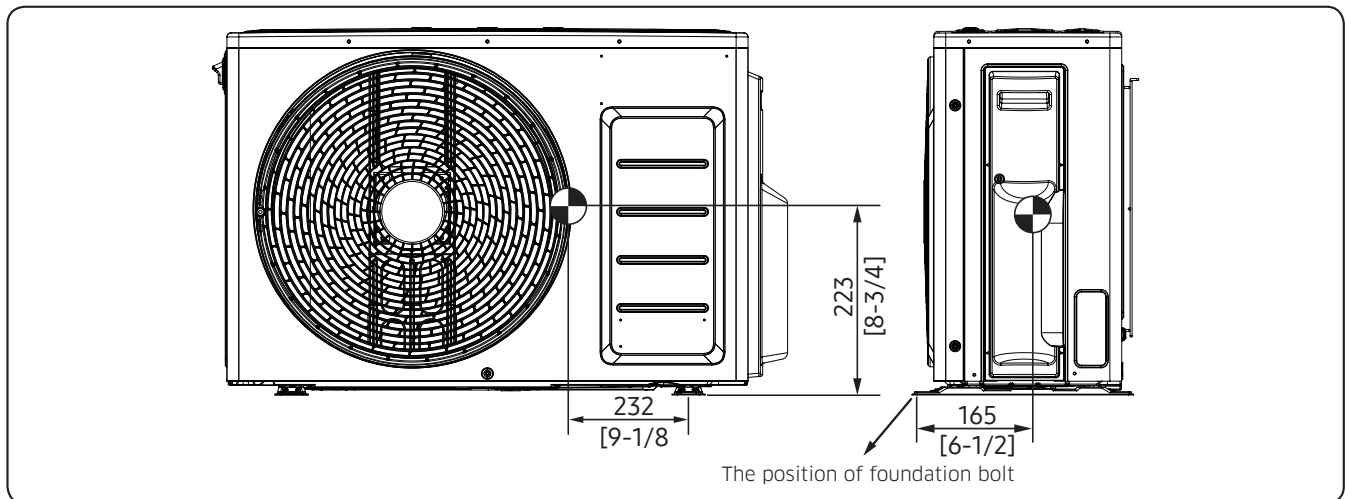

AC052RXADKG/EU

Units : mm [inches]

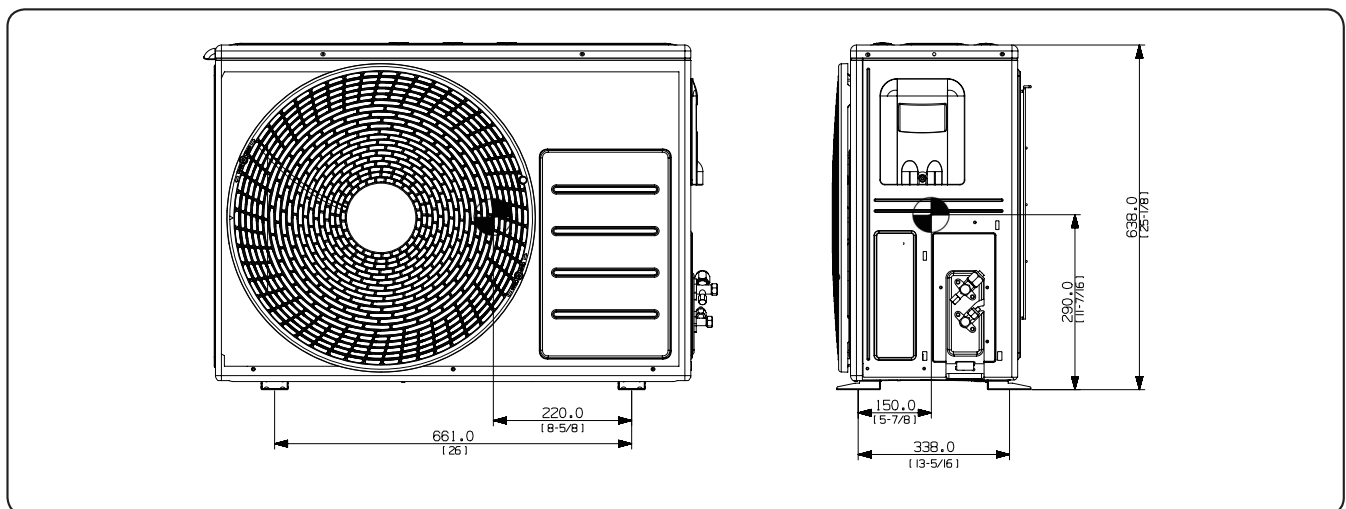

3. Center of Gravity

AC071RXADKG/EU

Units : mm [inches]

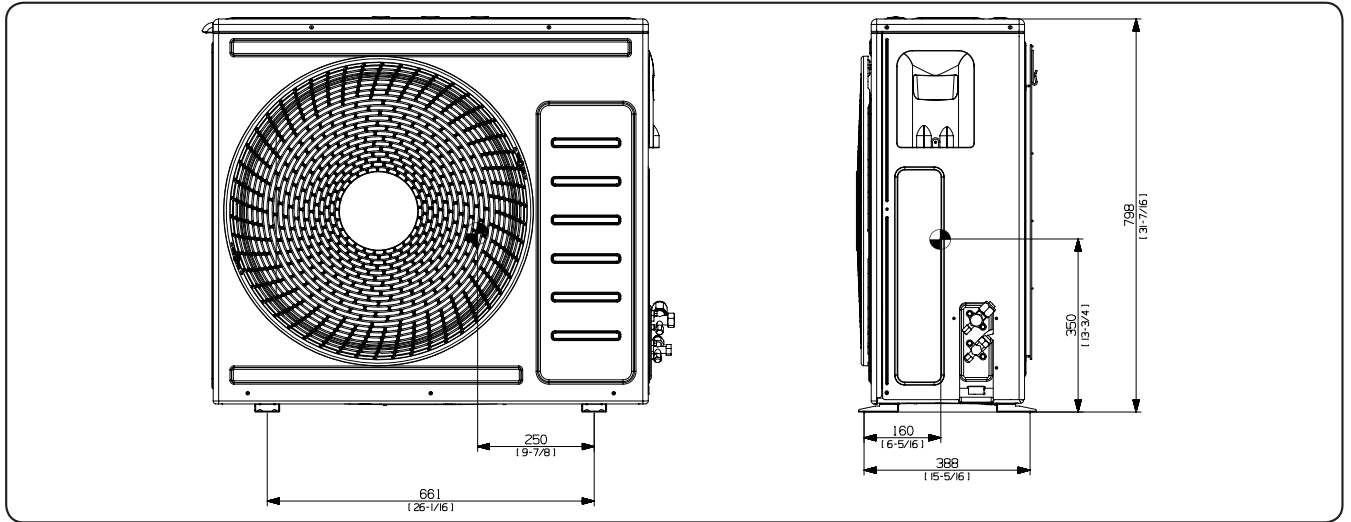

4. Electrical Wiring Diagram

Outdoor Units

AC026/035RXADKG/EU

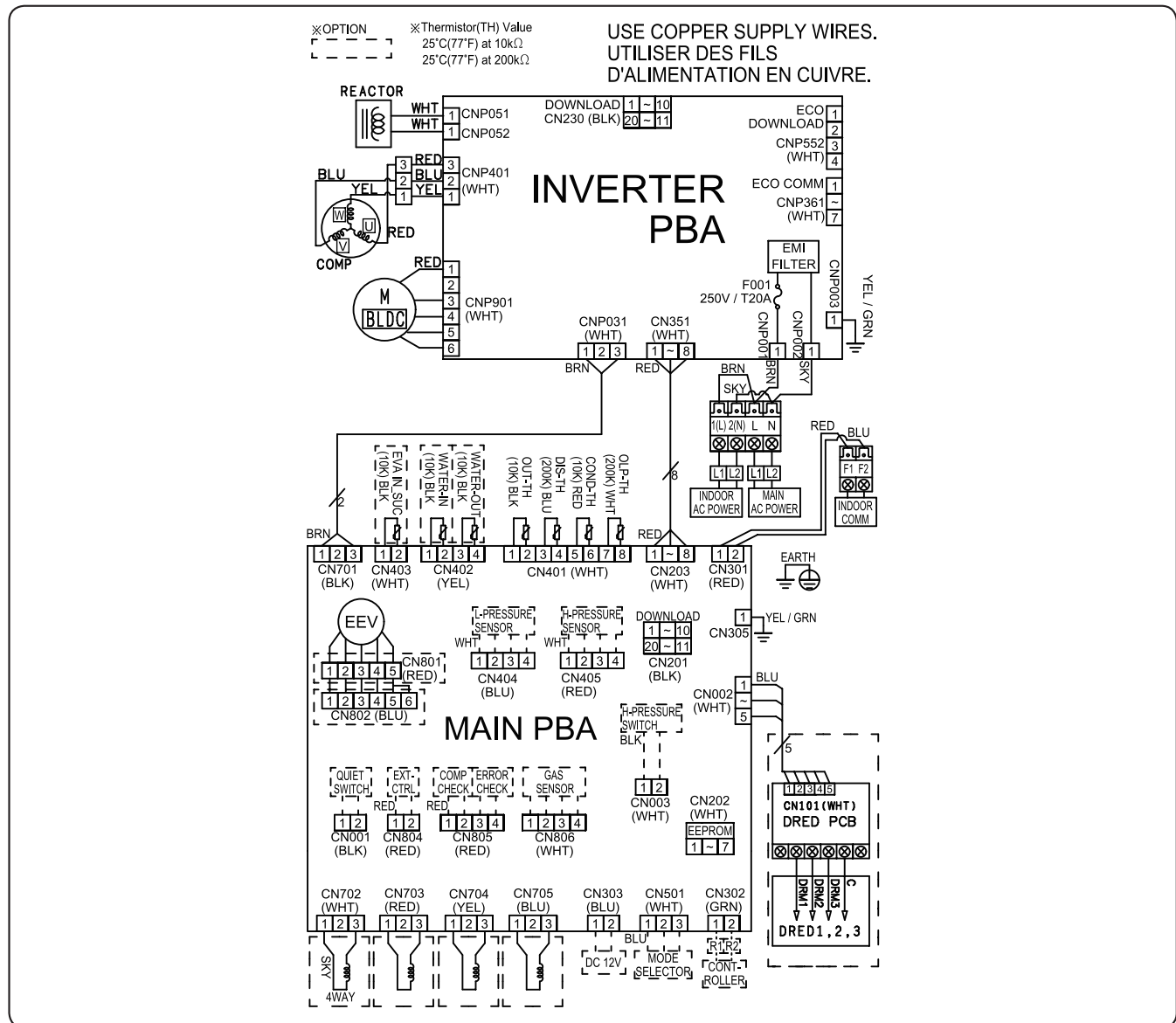

DRED PCB	Printed circuit board(DRED)	H-PRESSURE SWITCH	High Pressure Switch	M-BLDC	BLDC Motor
EEV	Electronic Expansion Valve	OUT-TH(10K)	Thermistor AMBIENT	DIS-TH(200K)	Thermistor DISCHARGE
COND-TH(10K)	Thermistor CONDENSOR	OLP-TH(200K)	Thermistor OLP		

NOTE

- This wiring diagram applies only to the outdoor unit.
- Colors blk: black, red: red, blu: blue, wht: white, yel: yellow, brn: brown, sky: skyblue
- When operating, don't shortcircuit the protection device (High Pressure switch)
- For connection wiring indoor-outdoor transmission F1-F2, outdoor-outdoor transmission OF1-OF2, refer to the installation manual.
- Protective earth(screw), : connector, : The wire quantity

4. Electrical Wiring Diagram

Outdoor Units

AC052/071RXADKG/EU

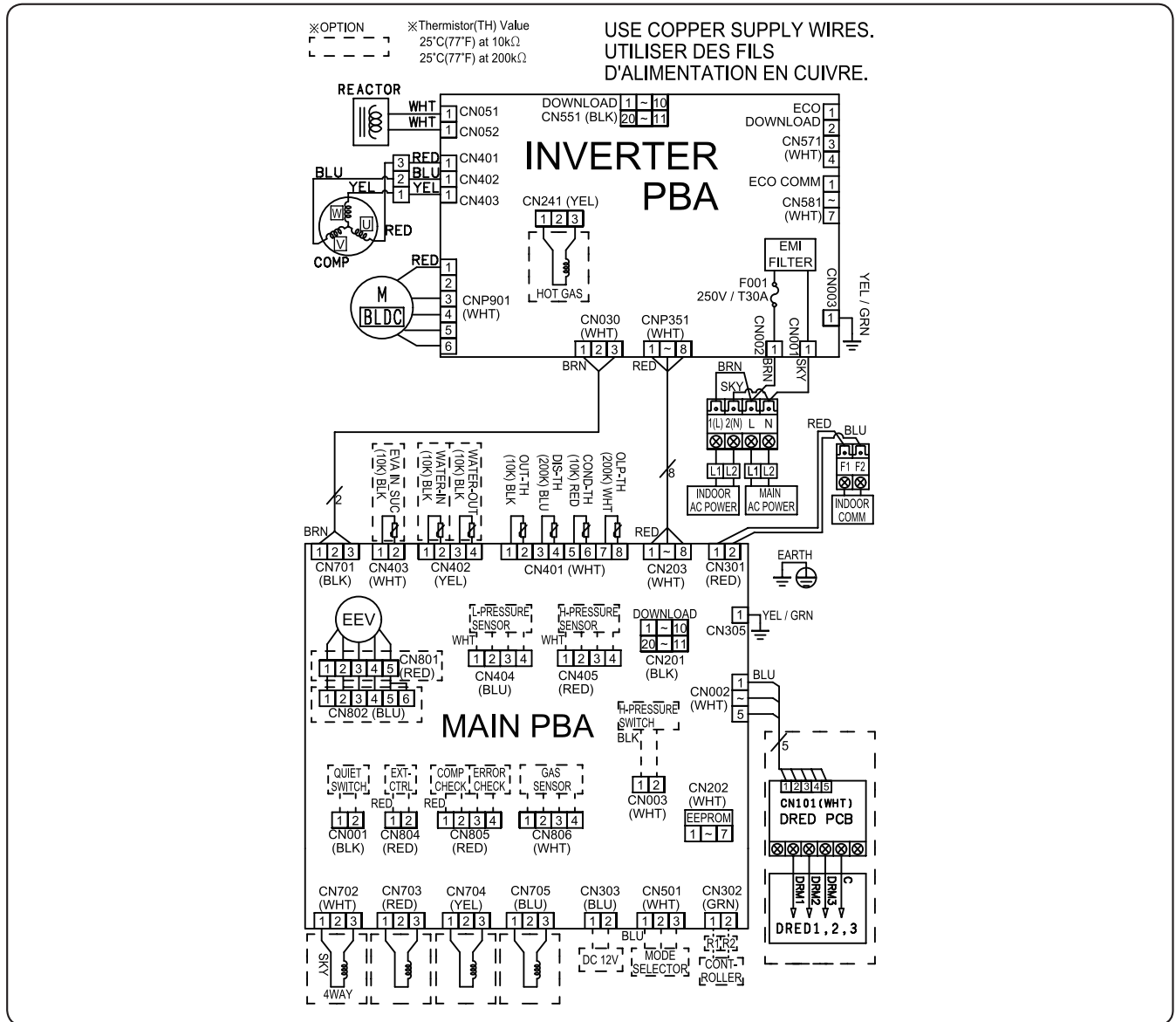

DRED PCB	Printed circuit board(DRED)	H-PRESSURE SWITCH	High Pressure Switch	M-BLDC	BLDC Motor
EEV	Electronic Expansion Valve	OUT-TH(10K)	Thermistor AMBIENT	DIS-TH(200K)	Thermistor DISCHARGE
COND-TH(10K)	Thermistor CONDENSOR	OLP-TH(200K)	Thermistor OLP		

NOTE

- This wiring diagram applies only to the outdoor unit.
- Colors blk: black, red: red, blu: blue, wht: white, yel: yellow, brn: brown, sky: skyblue
- When operating, don't shortcircuit the protection device (High Pressure switch)
- For connection wiring indoor-outdoor transmission F1-F2, outdoor-outdoor transmission OF1-OF2, refer to the installation manual.
- Protective earth(screw), : connector, : The wire quantity

5. Sound Data

Outdoor Units

Sound Pressure level

Unit: dB(A)

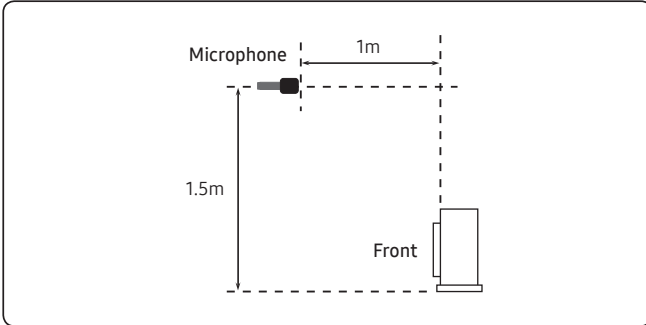

Model	Cooling	Heating
AC026RXADKG/EU	46	47
AC035RXADKG/EU	48	48
AC052RXADKG/EU	48	48
AC071RXADKG/EU	49	51

- NR Curve

1) AC026RXADKG/EU

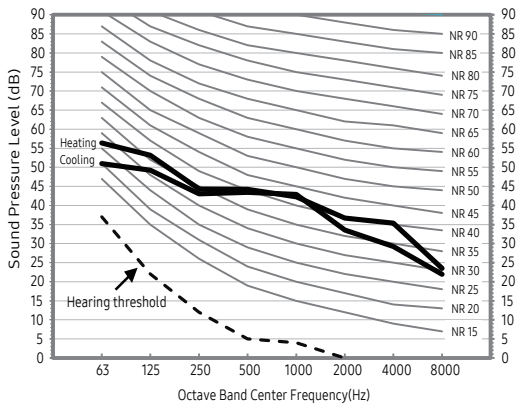

2) AC035RXADKG/EU

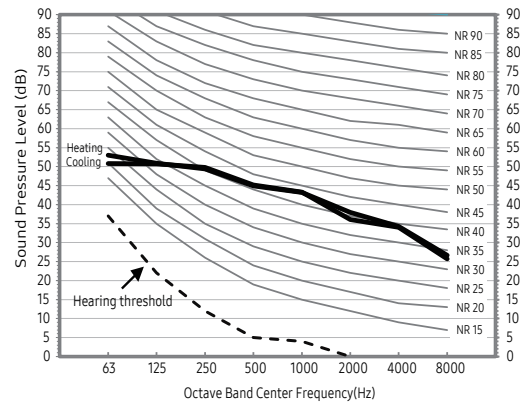

3) AC052RXADKG/EU

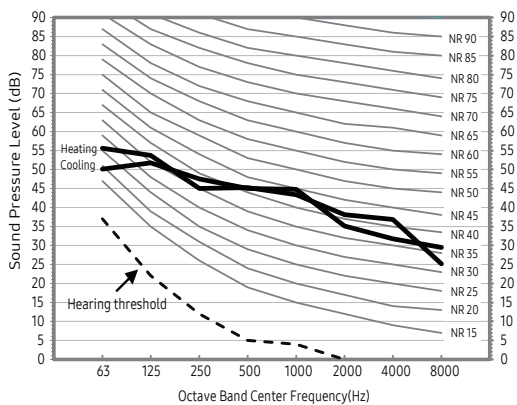

4) AC071RXADKG/EU

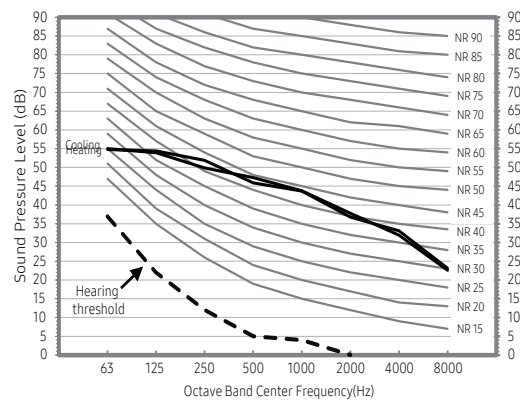

NOTE

- Specifications may be subject to change without prior notice.
 - Sound pressure level is obtained in an anechoic room.
 - Sound pressure level is a relative value, depending on the distance and acoustic environment.
 - Sound pressure level may differ depending on operation condition.
 - dB(A) = A weighted sound pressure level
 - Reference acoustic pressure 0 dB = 20μPa

5. Sound Data

Outdoor Units

Sound Power level

NOTE

Unit: dB(A)

- Specifications may be subject to change without prior notice
 - Sound power level is an absolute value that a sound source generates.
 - dBA = A-weighted sound power level.
 - Reference power : 1pW.
 - Measured according to ISO 3741.

Model	Power
AC026RXADKG/EU	59
AC035RXADKG/EU	61
AC052RXADKG/EU	62
AC071RXADKG/EU	65

• NR Curve

1) AC026RXADKG/EU

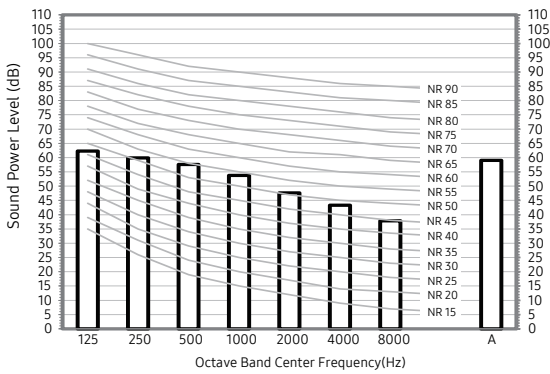

2) AC035RXADKG/EU

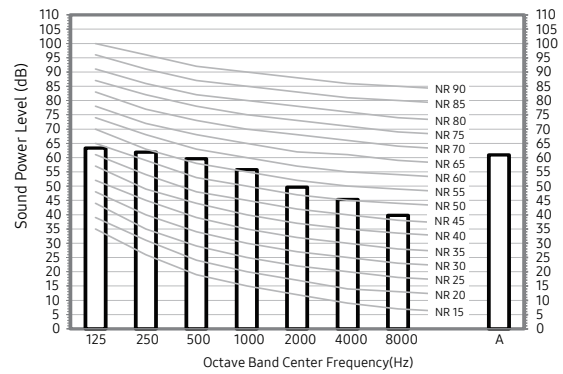

3) AC052RXADKG/EU

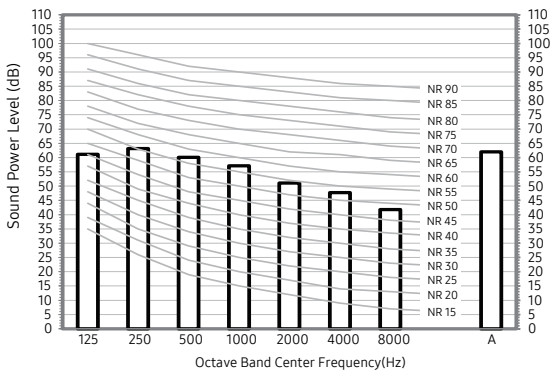

4) AC071RXADKG/EU

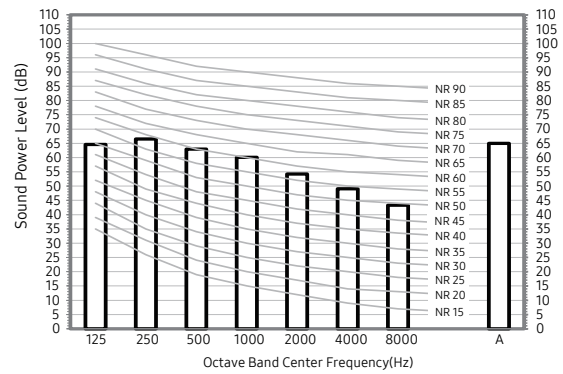

6. Capacity Correction

Outdoor Units

AC026/035RXADKG/EU

Cooling



		Pipe Length (m)			
		5	10	15	20
Level Difference (m)	30	-	-	-	-
	25	-	-	-	-
	20	-	-	-	-
	15	-	-	-	0.92
	10	-	-	0.95	0.92
	5	-	0.97	0.95	0.92
	0	1	0.97	0.95	0.92
	-5	-	0.96	0.94	0.91
	-10	-	-	0.92	0.90
	-15	-	-	-	0.88
	-20	-	-	-	-
	-25	-	-	-	-
	-30	-	-	-	-

Heating



		Pipe Length (m)			
		5	10	15	20
Level Difference (m)	30	-	-	-	-
	25	-	-	-	-
	20	-	-	-	-
	15	-	-	-	0.92
	10	-	-	0.95	0.92
	5	-	0.97	0.95	0.92
	0	1	0.97	0.95	0.92
	-5	-	0.97	0.95	0.92
	-10	-	-	0.95	0.92
	-15	-	-	-	0.92
	-20	-	-	-	-
	-25	-	-	-	-
	-30	-	-	-	-

6. Capacity Correction

Outdoor Units

AC052RXADKG/EU

Cooling



		Pipe Length (m)					
		5	10	15	20	25	30
Level Difference (m)	30	-	-	-	-	-	-
	25	-	-	-	-	-	-
	20	-	-	-		0.92	0.90
	15	-	-		0.94	0.92	0.90
	10	-		0.96	0.94	0.92	0.90
	5		0.98	0.96	0.94	0.92	0.90
	0	1	0.98	0.96	0.94	0.92	0.90
	-5		0.97	0.95	0.93	0.91	0.89
	-10	-		0.94	0.93	0.91	0.89
	-15	-	-		0.92	0.90	0.88
	-20	-	-	-	-	0.89	0.86
	-25	-	-	-	-	-	-
	-30	-	-	-	-	-	-

Heating



		Pipe Length (m)					
		5	10	15	20	25	30
Level Difference (m)	30	-	-	-	-	-	-
	25	-	-	-	-	-	-
	20	-	-	-	-	0.94	0.92
	15	-	-	-	0.95	0.94	0.92
	10	-	-	0.97	0.95	0.94	0.92
	5	-	0.98	0.97	0.95	0.94	0.92
	0	1	0.98	0.97	0.95	0.94	0.92
	-5	-	0.98	0.97	0.95	0.94	0.92
	-10	-	-	0.97	0.95	0.94	0.92
	-15	-	-	-	0.95	0.94	0.92
	-20	-	-	-	-	0.94	0.92
	-25	-	-	-	-	-	-
	-30	-	-	-	-	-	-

6. Capacity Correction

Outdoor Units

AC071RXADKG/EU

Cooling



		Pipe Length (m)									
		5	10	15	20	25	30	35	40	45	50
Level Difference (m)	30	-	-	-	-	-	-	0.93	0.92	0.91	0.90
	25	-	-	-	-	-	0.94	0.93	0.92	0.91	0.90
	20	-	-	-	-	0.96	0.94	0.93	0.92	0.91	0.90
	15	-	-	-	0.97	0.96	0.94	0.93	0.92	0.91	0.90
	10	-	-	0.98	0.97	0.96	0.94	0.93	0.92	0.91	0.90
	5	-	0.99	0.98	0.97	0.96	0.94	0.93	0.92	0.91	0.90
	0	1	0.99	0.98	0.97	0.96	0.94	0.93	0.92	0.91	0.90
	-5	-	0.98	0.97	0.96	0.95	0.94	0.93	0.92	0.91	0.89
	-10	-	-	0.97	0.96	0.95	0.94	0.92	0.91	0.90	0.88
	-15	-	-	-	0.95	0.95	0.93	0.92	0.91	0.89	0.88
	-20	-	-	-	-	0.94	0.93	0.92	0.90	0.89	0.87
	-25	-	-	-	-	-	0.92	0.91	0.90	0.88	0.86
	-30	-	-	-	-	-	-	0.91	0.89	0.88	0.85

Heating



		Pipe Length (m)									
		5	10	15	20	25	30	35	40	45	50
Level Difference (m)	30	-	-	-	-	-	-	0.95	0.94	0.93	0.92
	25	-	-	-	-	-	0.96	0.95	0.94	0.93	0.92
	20	-	-	-	-	0.96	0.96	0.95	0.94	0.93	0.92
	15	-	-	-	0.97	0.96	0.96	0.95	0.94	0.93	0.92
	10	-	-	0.98	0.97	0.96	0.96	0.95	0.94	0.93	0.92
	5	-	0.99	0.98	0.97	0.96	0.96	0.95	0.94	0.93	0.92
	0	1	0.99	0.98	0.97	0.96	0.96	0.95	0.94	0.93	0.92
	-5	-	0.99	0.98	0.97	0.96	0.96	0.95	0.94	0.93	0.92
	-10	-	-	0.98	0.97	0.96	0.96	0.95	0.94	0.93	0.92
	-15	-	-	-	0.97	0.96	0.96	0.95	0.94	0.93	0.92
	-20	-	-	-	-	0.96	0.96	0.95	0.94	0.93	0.92
	-25	-	-	-	-	-	0.96	0.95	0.94	0.93	0.92
	-30	-	-	-	-	-	-	0.95	0.94	0.93	0.92

7. Operation Range

AC026/035RXADKG/EU

Mode	Outdoor Unit	Indoor Unit	Indoor Unit
	Temperature(DB)	Temperature(DB)	Humidity(RH)
Cooling	-15°C ~ 46°C	18°C ~ 32°C	80% or less
Heating	-20°C ~ 24°C	30°C or less	-
Drying	-15°C ~ 46°C	18°C ~ 32°C	80% or less

AC052/071RXADKG/EU

Mode	Outdoor Unit	Indoor Unit	Indoor Unit
	Temperature(DB)	Temperature(DB)	Humidity(RH)
Cooling	-15°C ~ 50°C	18°C ~ 32°C	80% or less
Heating	-20°C ~ 24°C	30°C or less	-
Drying	-15°C ~ 50°C	18°C ~ 32°C	80% or less

NOTE







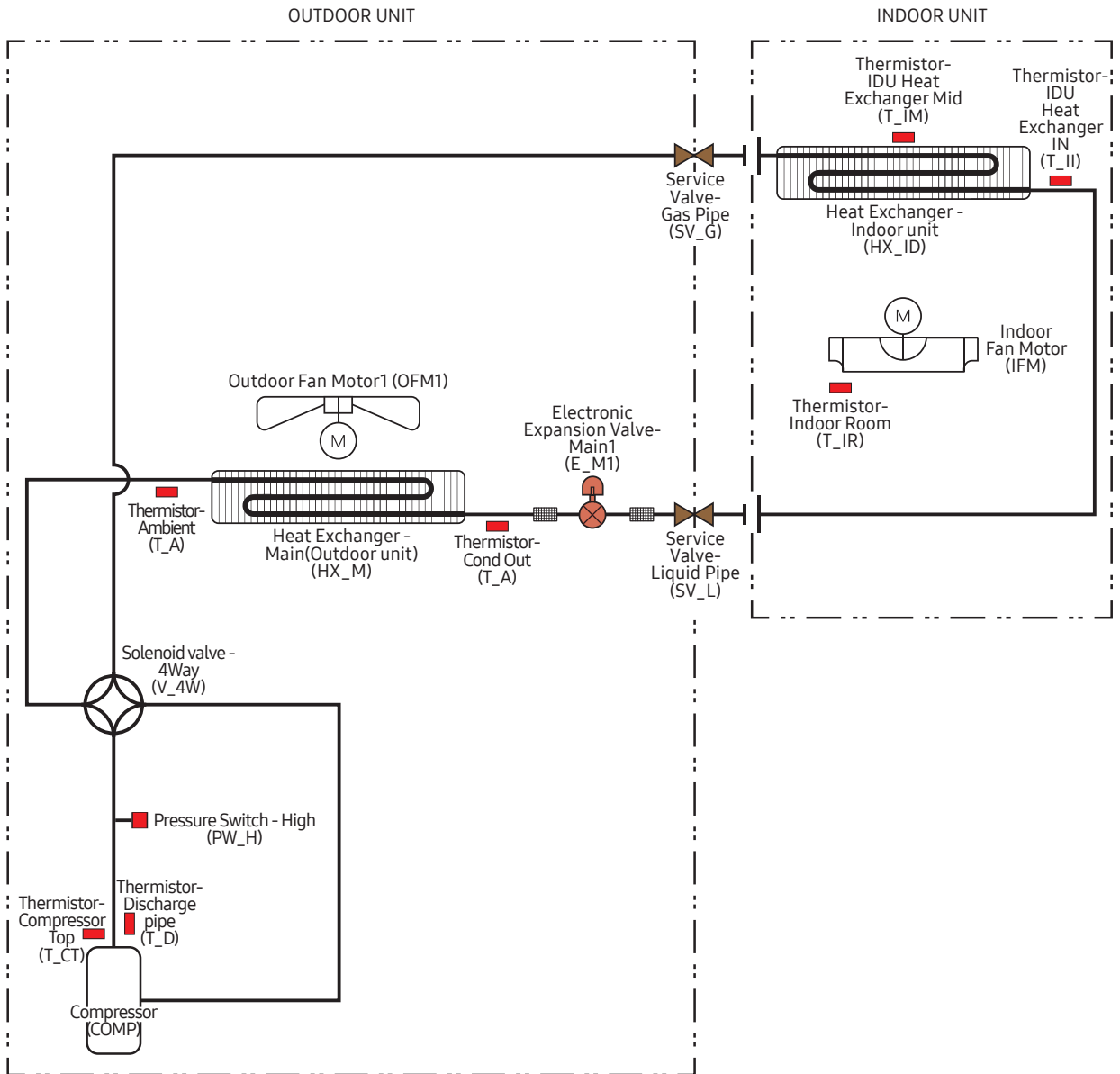



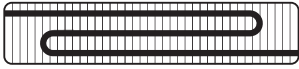
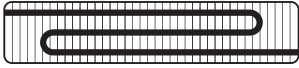



- The assumed installation conditions are follows
 - The pipe length(including elbow) is 5 m.
 - The level difference is 0 m.

8. Piping Diagram

AC026RNNDKG/EU+AC026RXADKG/EU
 AC035RNNDKG/EU+AC035RXADKG/EU

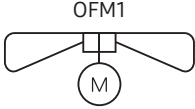
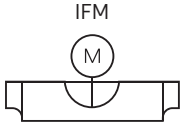

8. Piping Diagram







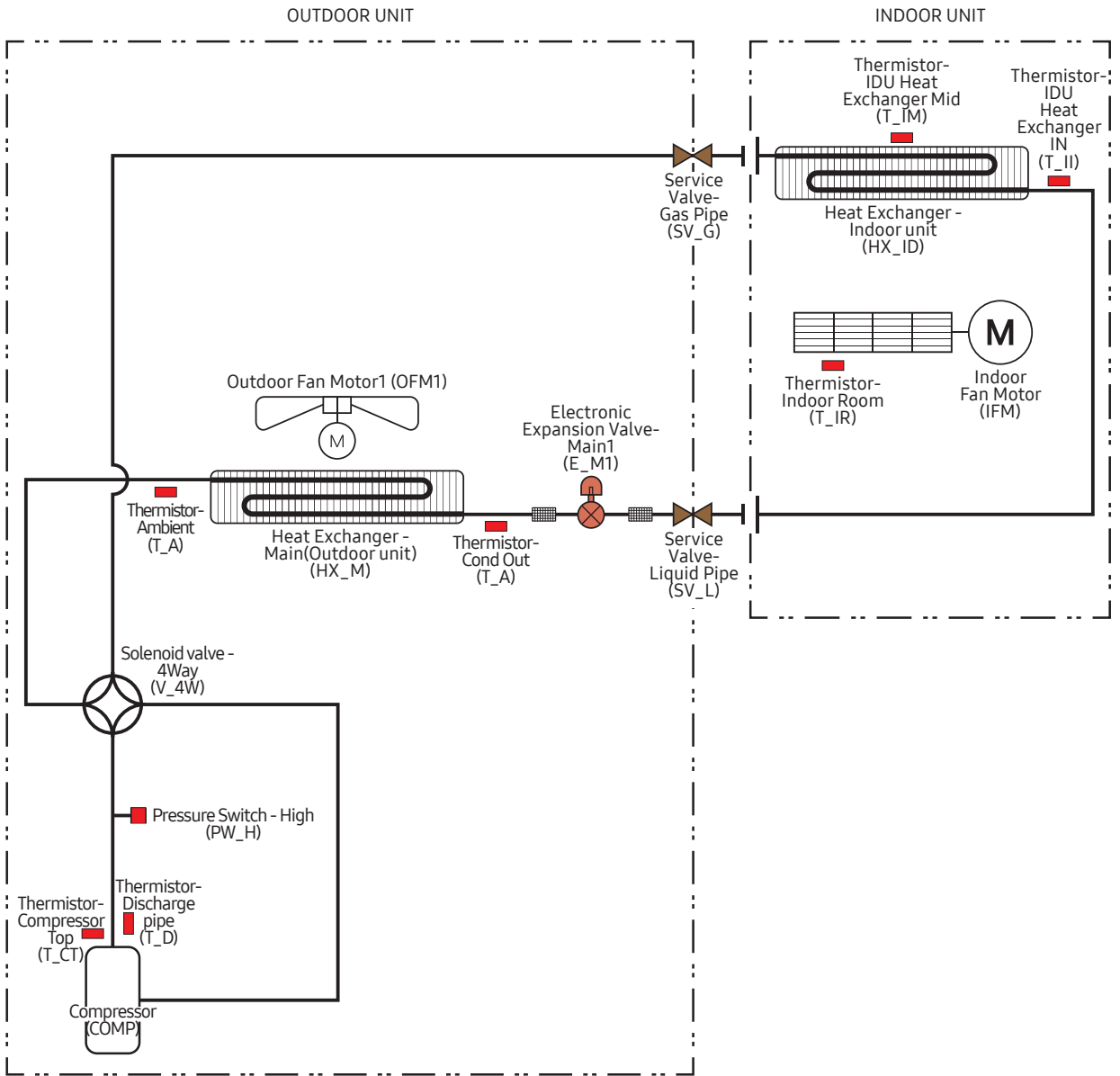



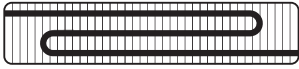





Category	Symbol	Description
Compressor		Compressor
Heat Exchanger	 HX_M	Heat Exchanger - Main (Outdoor unit)
	 HX_ID	Heat Exchanger - Indoor unit
Filter		Filter
EEV	 E_M	Electronic Expansion valve - Main
Solenoid Valve	 V_4W	Solenoid valve - 4Way
Valve (etc)	 SV_G	Service Valve - Gas Pipe
	 SV_L	Service Valve - Liquid Pipe
Thermistor	 T_CT	Thermistor - Compressor Top
	 T_D	Thermistor - Discharge pipe
	 T_CO	Thermistor - Cond Out
	 T_A	Thermistor - Ambient
	 T_IR	Thermistor - Indoor Room
	 T_IM	Thermistor - IDU Heat Exchanger Mid
	 T_II	Thermistor - IDU Heat Exchanger In
Fan	 OFM1	Outdoor Fan Motor 1
	 IFM	Indoor Fan Motor
Pressure switch	 PW_H	Pressure Switch - High

8. Piping Diagram

AC026RN1DKG/EU+AC026RXADKG/EU
 AC026RNADKH/EU+AC026RXADKG/EU
 AC035RN1DKH/EU+AC035RXADKG/EU
 AC035RNADKH/EU+AC035RXADKG/EU

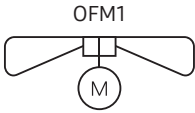
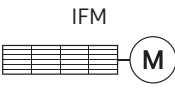

8. Piping Diagram







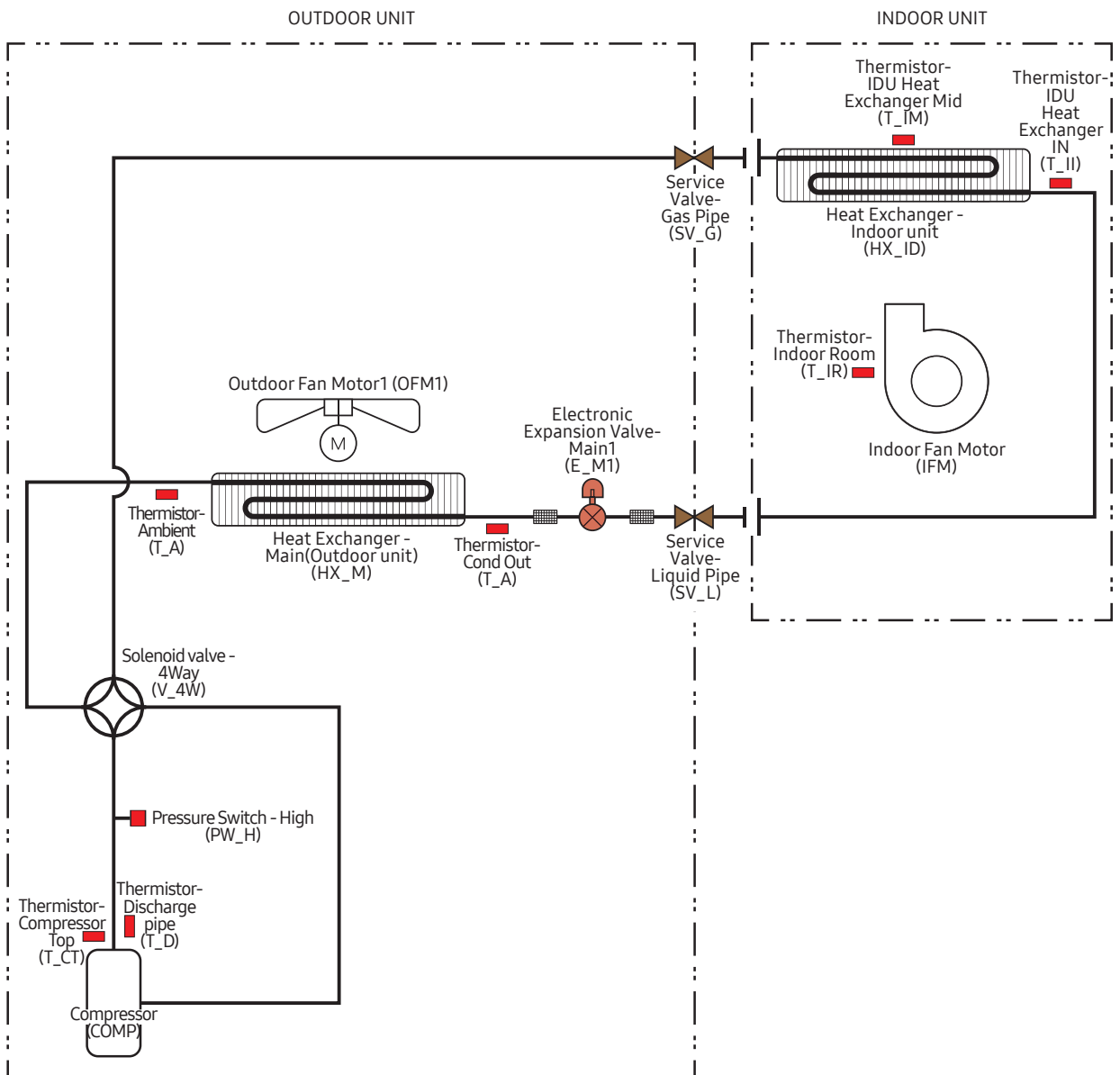



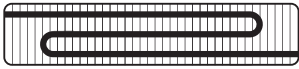





Category	Symbol	Description
Compressor		Compressor
Heat Exchanger	 HX_M	Heat Exchanger - Main (Outdoor unit)
	 HX_ID	Heat Exchanger - Indoor unit
Filter		Filter
EEV	 E_M	Electronic Expansion valve - Main
Solenoid Valve	 V_4W	Solenoid valve - 4Way
Valve (etc)	 SV_G	Service Valve - Gas Pipe
	 SV_L	Service Valve - Liquid Pipe
Thermistor	 T_CT	Thermistor - Compressor Top
	 T_D	Thermistor - Discharge pipe
	 T_CO	Thermistor - Cond Out
	 T_A	Thermistor - Ambient
	 T_IR	Thermistor - Indoor Room
	 T_IM	Thermistor - IDU Heat Exchanger Mid
	 T_II	Thermistor - IDU Heat Exchanger In
Fan	 OFM1	Outdoor Fan Motor 1
	 IFM	Indoor Fan Motor
Pressure switch	 PW_H	Pressure Switch - High

8. Piping Diagram

AC026RNLDKG/EU+AC026RXADKG/EU
 AC035RNLDKG/EU+AC035RXADKG/EU
 AC035RNMDKG/EU+AC035RXADKG/EU

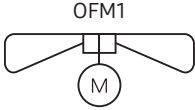

8. Piping Diagram







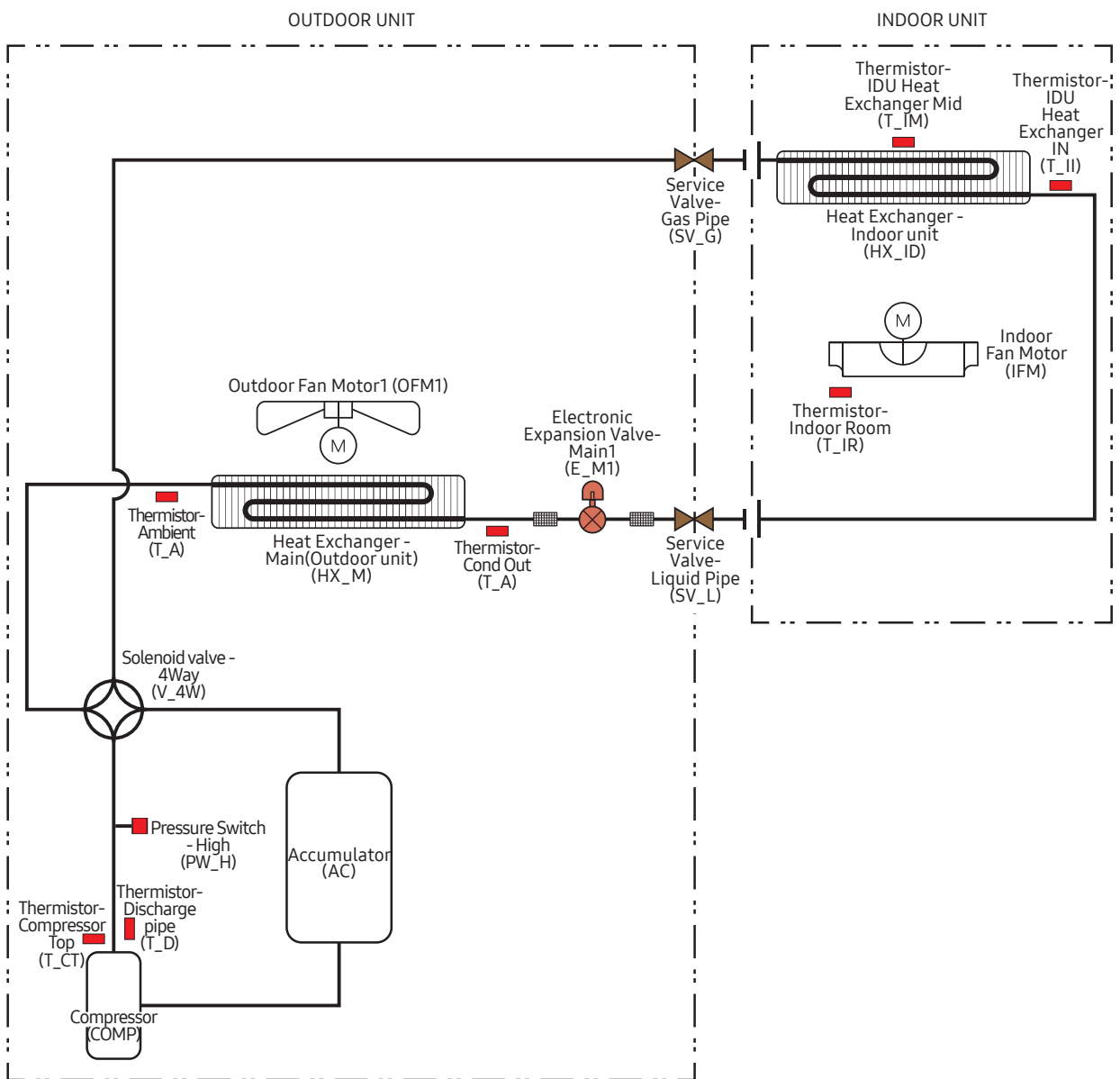



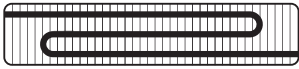
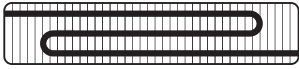





Category	Symbol	Description
Compressor		Compressor
Heat Exchanger	 HX_M	Heat Exchanger - Main (Outdoor unit)
	 HX_ID	Heat Exchanger - Indoor unit
Filter		Filter
EEV	 E_M	Electronic Expansion valve - Main
Solenoid Valve	 V_4W	Solenoid valve - 4Way
Valve (etc)	 SV_G	Service Valve - Gas Pipe
	 SV_L	Service Valve - Liquid Pipe
Thermistor	 T_CT	Thermistor - Compressor Top
	 T_D	Thermistor - Discharge pipe
	 T_CO	Thermistor - Cond Out
	 T_A	Thermistor - Ambient
	 T_IR	Thermistor - Indoor Room
	 T_IM	Thermistor - IDU Heat Exchanger Mid
	 T_II	Thermistor - IDU Heat Exchanger In
Fan	 OFM1	Outdoor Fan Motor 1
	 IFM	Indoor Fan Motor
Pressure switch	 PW_H	Pressure Switch - High

8. Piping Diagram

AC052RNNDKG/EU+AC052RXADKG/EU
 AC052RN4DKG/EU+AC052MXADKG/EU
 AC071RNNDKG/EU+AC071MXADKG/EU
 AC071RN4DKG/EU+AC071MXADKG/EU
 AC071RN4PKG/EU+AC071MXADKG/EU

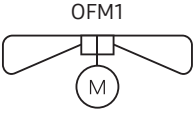
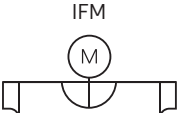

8. Piping Diagram







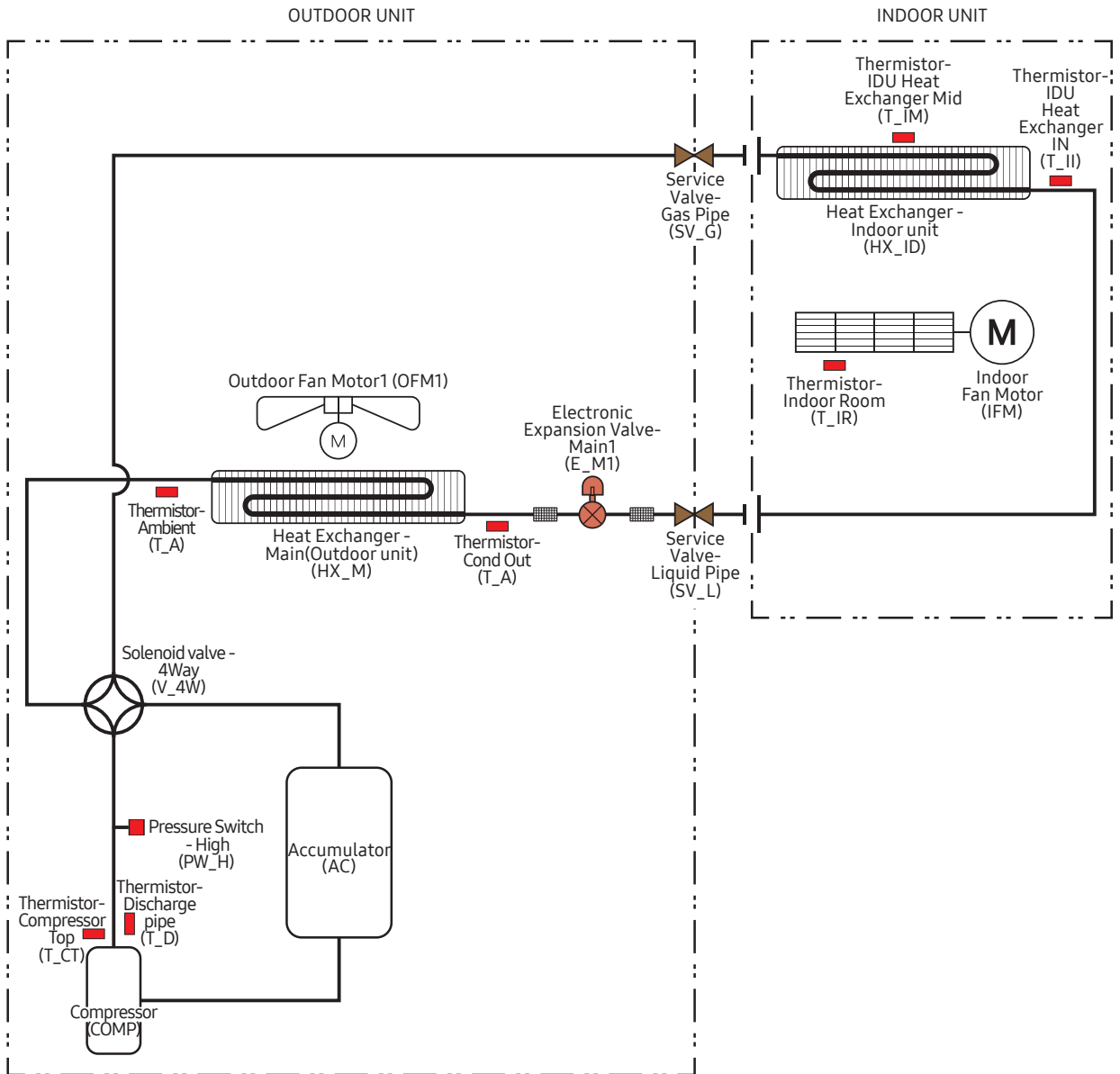











Category	Symbol	Description
Compressor		Compressor
Heat Exchanger	 HX_M	Heat Exchanger - Main (Outdoor unit)
	 HX_ID	Heat Exchanger - Indoor unit
Tank		Accumulator
Filter		Filter
EEV	 E_M	Electronic Expansion valve - Main
Solenoid Valve	 V_4W	Solenoid valve - 4Way
Valve (etc)	 SV_G	Service Valve - Gas Pipe
	 SV_L	Service Valve - Liquid Pipe
Thermistor	 T_CT	Thermistor - Compressor Top
	 T_D	Thermistor - Discharge pipe
	 T_CO	Thermistor - Cond Out
	 T_A	Thermistor - Ambient
	 T_IR	Thermistor - Indoor Room
	 T_IM	Thermistor - IDU Heat Exchanger Mid
	 T_II	Thermistor - IDU Heat Exchanger In
Fan	 OFM1	Outdoor Fan Motor 1
	 IFM	Indoor Fan Motor
Pressure switch	 PW_H	Pressure Switch - High

8. Piping Diagram

AC052RNADKG/EU+AC052RXADKG/EU
 AC071RNADKG/EU+AC071RXADKG/EU

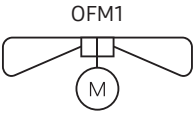

8. Piping Diagram







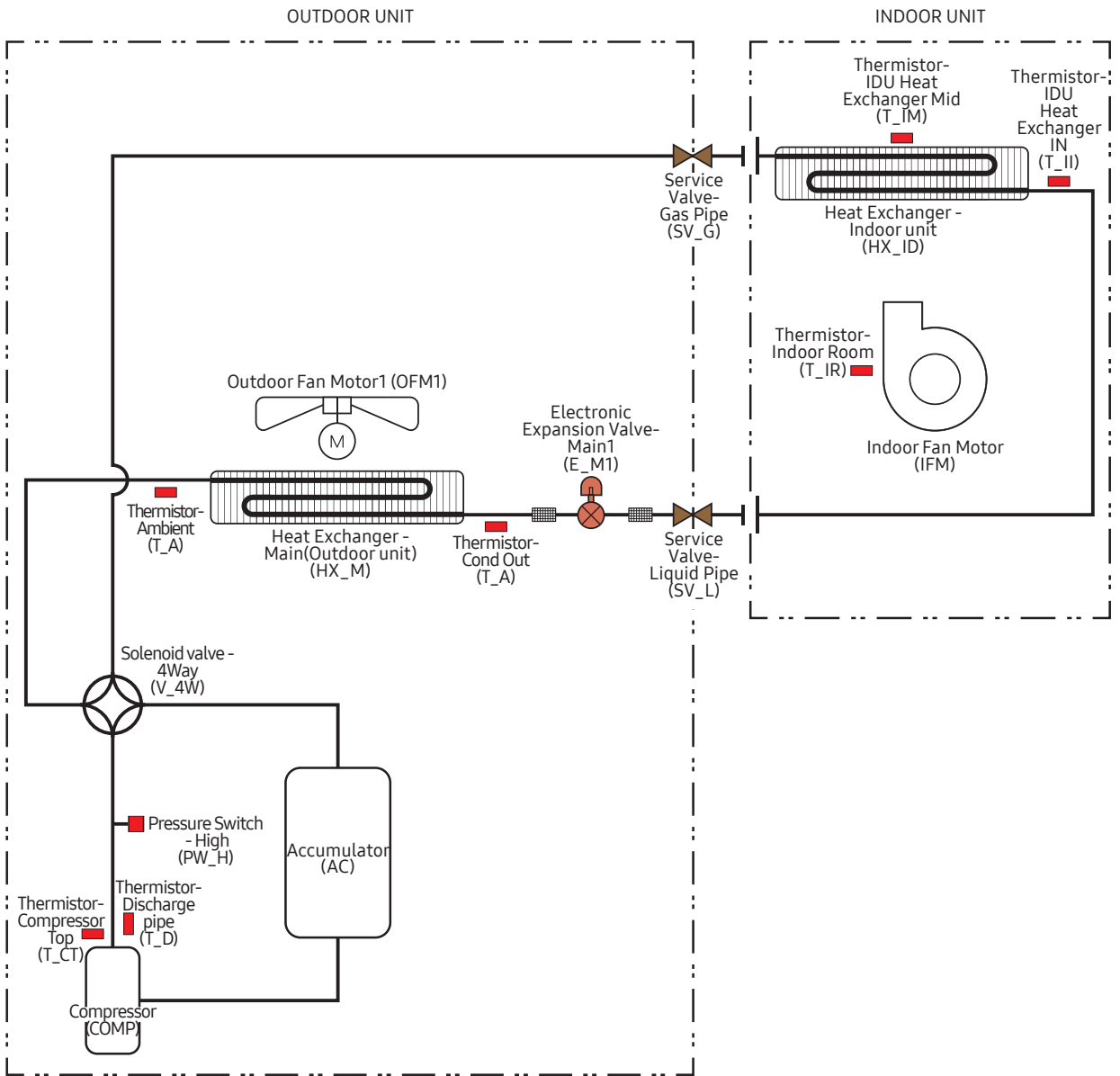



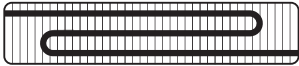





Category	Symbol	Description
Compressor		Compressor
Heat Exchanger	 HX_M	Heat Exchanger - Main (Outdoor unit)
	 HX_ID	Heat Exchanger - Indoor unit
Tank		Accumulator
Filter		Filter
EEV	 E_M	Electronic Expansion valve - Main
Solenoid Valve	 V_4W	Solenoid valve - 4Way
Valve (etc)	 SV_G	Service Valve - Gas Pipe
	 SV_L	Service Valve - Liquid Pipe
Thermistor	 T_CT	Thermistor - Compressor Top
	 T_D	Thermistor - Discharge pipe
	 T_CO	Thermistor - Cond Out
	 T_A	Thermistor - Ambient
	 T_IR	Thermistor - Indoor Room
	 T_IM	Thermistor - IDU Heat Exchanger Mid
	 T_II	Thermistor - IDU Heat Exchanger In
Fan	 OFM1	Outdoor Fan Motor1
	 IFM	Indoor Fan Motor
Pressure switch	 PW_H	Pressure Switch - High

8. Piping Diagram

AC052RNCDKG/EU+AC052RXADKG/EU
 AC052RNMDKG/EU+AC052RXADKG/EU
 AC052RNLDKG/EU+AC052RXADKG/EU
 AC071RNCDKG/EU+AC071RXADKG/EU
 AC071RNMDKG/EU+AC071RXADKG/EU
 AC071RNLDKG/EU+AC071RXADKG/EU

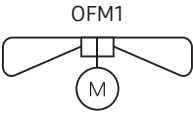

8. Piping Diagram

Category	Symbol	Description
Compressor		Compressor
Heat Exchanger	 HX_M	Heat Exchanger - Main (Outdoor unit)
	 HX_ID	Heat Exchanger - Indoor unit
Tank		Accumulator
Filter		Filter
EEV	 E_M	Electronic Expansion valve - Main
Solenoid Valve	 V_4W	Solenoid valve - 4Way
Valve (etc)	 SV_G	Service Valve - Gas Pipe
	 SV_L	Service Valve - Liquid Pipe
Thermistor	 T_CT	Thermistor - Compressor Top
	 T_D	Thermistor - Discharge pipe
	 T_CO	Thermistor - Cond Out
	 T_A	Thermistor - Ambient
	 T_IR	Thermistor - Indoor Room
	 T_IM	Thermistor - IDU Heat Exchanger Mid
	 T_II	Thermistor - IDU Heat Exchanger In
Fan	 OFM1	Outdoor Fan Motor1
	 IFM	Indoor Fan Motor
Pressure switch	 PW_H	Pressure Switch - High

Installation

1. (Wind-Free) 1Way & 4Way Cassette

Spacing requirements

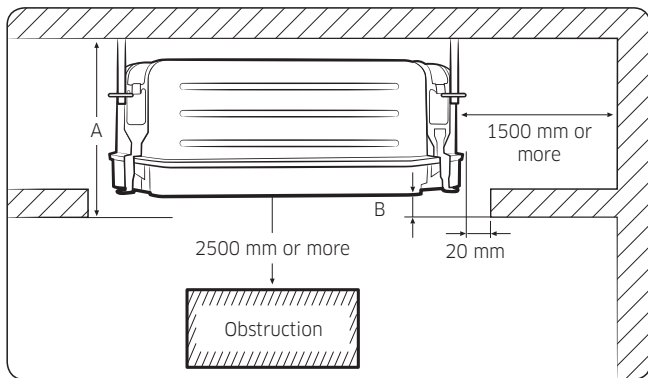

Model	AC026RN1DKG AC035RN1DKG	AC052RN4DKG AC071RN4DKG
A	170 mm	251 mm
B	15 mm	17 mm

(Unit: mm)

1 way Cassette

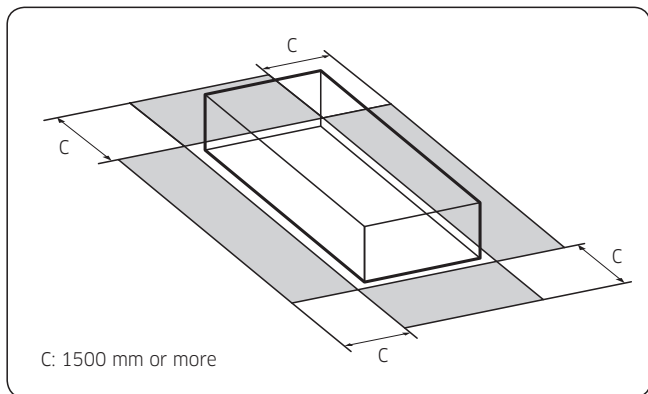

4 way Cassette

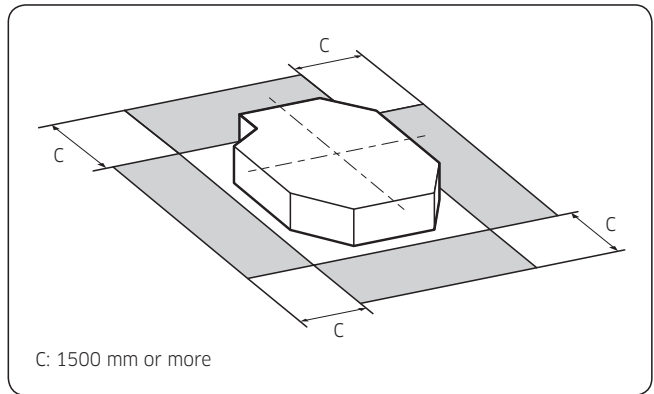

⚠ CAUTION

- Comply with the length and height limits described in the figure above.
- For the product that uses the R-32 refrigerant, Install the indoor unit on the wall 1.8 m or higher from the floor.
- The indoor unit must be installed according to the specified distances in order to permit accessibility from each side, to guarantee correct operation, maintenance, and repair of the unit. The components of the indoor unit must be reachable and removable under safe conditions for people and the unit.
- Do not hold the discharge while carrying the indoor unit to avoid the possibility of breakage.
- You must hold the hanger plate on the corner and carry the indoor unit.

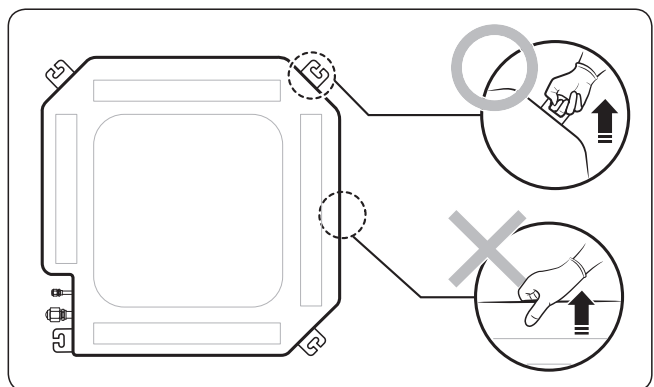

※ In case you want more information about the controllers and accessories, please refer to the Controller and Accessory TDB on pvi.Samsung.com site or Global Partner Portal site.

Installation

Optional: Insulating the body of the indoor unit

If you install a cassette type indoor unit on the ceiling when temperature is over 27°C and humidity is over 80%, you must apply an extra 10 mm thick polyethylene insulation or a similar type of insulation to the body of the indoor unit.

Cut away the part where pipes are pulled out for the insulating work.

1 way Cassette

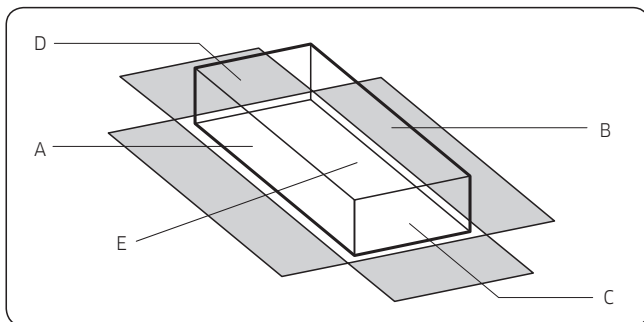

4 way Cassette

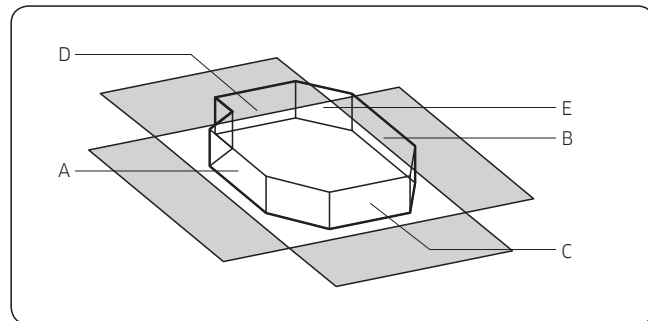

Insulate the end of the pipe and some curved area by using separate insulator.

NOTE

- A: Reference for the outer circumference of the unit (When insulating the body of the indoor unit, use A as the reference for its outer circumference.)

(Unit: mm)

Indoor unit		A	B	C	D	E
4 way Cassette <S> (840x204x840)	AC052RN4DKG	910x151	940x151	610x151	650x151	870x870
	AC071RN4DKG					
1 way Cassette (970x135x410)	AC026RN1DKG	990x155	990x155	430x155	430x155	990x430
	AC035RN1DKG					

※ In case you want more information about the controllers and accessories, please refer to the Controller and Accessory TDB on pvi.Samsung.com site or Global Partner Portal site.

Installing the indoor unit

When deciding on the location of the air conditioner the following restrictions must be taken into account.

- 1 Place the pattern sheet on the ceiling at the spot where you want to install the indoor unit.

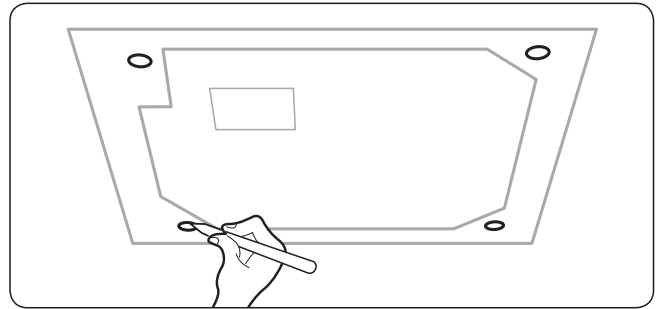

NOTE

- Since the diagram is made of paper, it may shrink or stretch slightly due to temperature or humidity. For this reason, before drilling the holes, be sure to maintain the correct dimensions between the markings.

- 2 Insert bolt anchors, use existing ceiling supports or construct a suitable support as shown in figure.

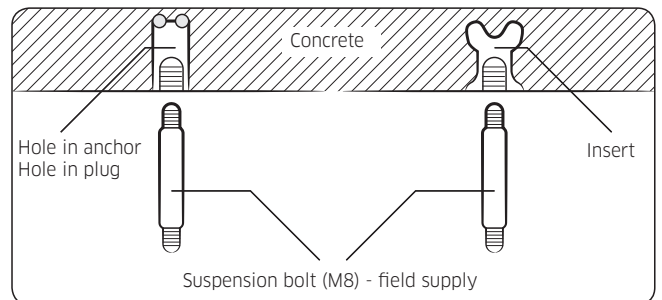

- 3 Install the suspension bolts, depending on the ceiling type.

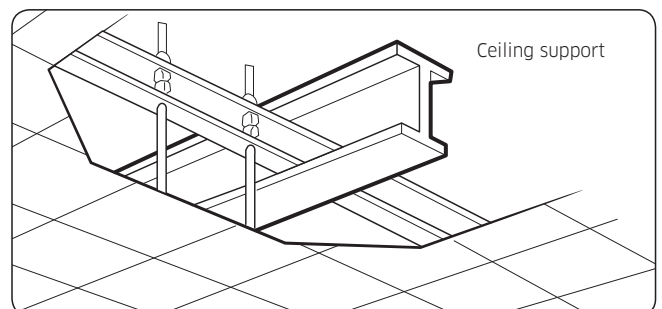

Installation

⚠ CAUTION

- Make sure that the ceiling is strong enough to support the weight of the indoor unit. Before hanging the unit, test the strength of each attached suspension bolt.
- If the length of the suspension bolt is more than 1.5 m, you are required to prevent vibration.

4 Screw eight pairs of nuts and washers to the suspension bolts, making space for hanging the indoor unit.

⚠ CAUTION

- You must install all of the suspension rods.
- It is important to leave sufficient space in the false ceiling to allow access for maintenance or repairs to the drainage pipe connection, the refrigerant pipe connection, or to remove the unit if necessary.

5 Hang the indoor unit to the suspension bolts between two nuts. Cut a pad stopper and place it on the suspension bolts to hold the washers. Remove the stopper and screw the nuts to fix the unit.

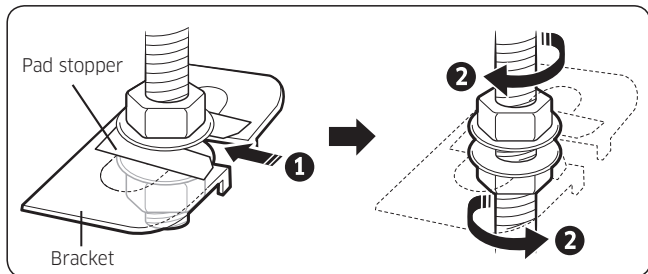

6 Check the level of the indoor unit by using a leveler.

- A tilt of the indoor unit may cause malfunction of a built-in float switch and water leaks.

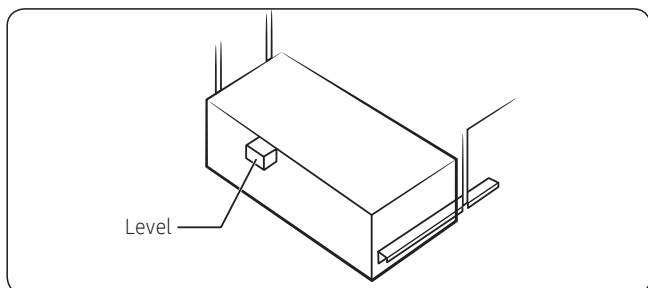

7 Adjust the unit to the appropriate position, taking into account the installation area for the front panel.

- Place the pattern sheet on the indoor unit.
- Adjust the space between the ceiling and the indoor unit by using a dimension gauge.
- Fix the indoor unit securely after adjusting the level of the unit by using a leveller.
- Remove the pattern sheet, connect the other cables, and install the front panel.

1way Cassette (Standard)

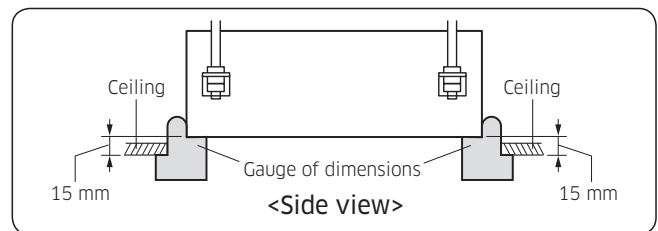

1way Cassette (Wind-Free)

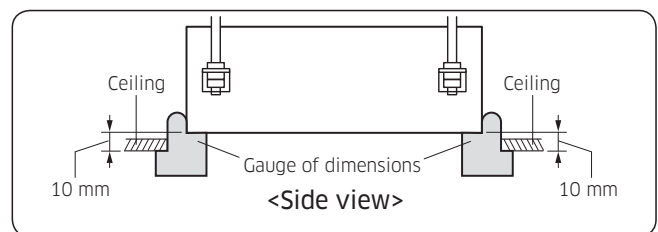

4 way Cassette

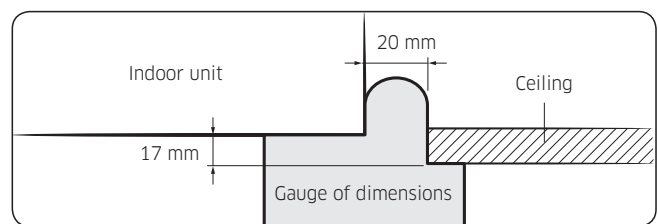

※ In case you want more information about the controllers and accessories, please refer to the Controller and Accessory TDB on pvi.Samsung.com site or Global Partner Portal site.

Installation

Installing the drain hose and drain pipe

- 1 Push the supplied drain hose as far as possible over the drain socket.
- 2 Tighten the metal clamp as shown in the picture.

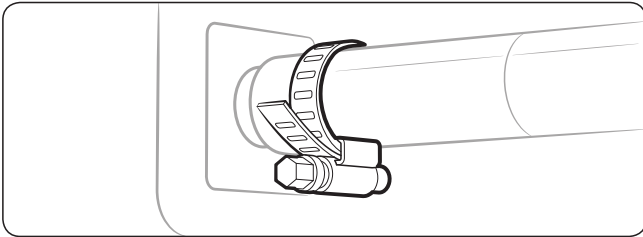

- 3 Wrap the supplied large sealing pad over the metal clamp and drain hose to insulate and fix it with clamps.
- 4 Insulate the complete drain piping inside the building (field supply).
If the drain hose cannot be sufficiently set on a slope, fit the hose with drain raising piping (field supply).
- 5 Push the drain hose up to insulation when connecting the drain hose to drain socket.

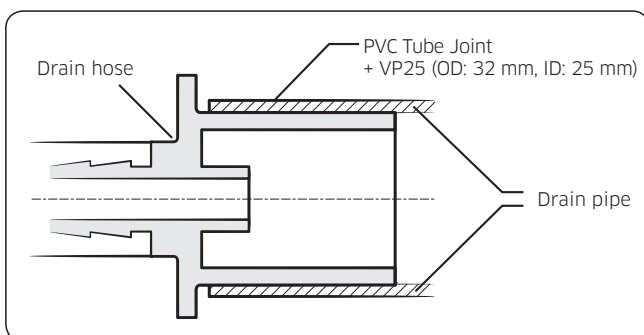
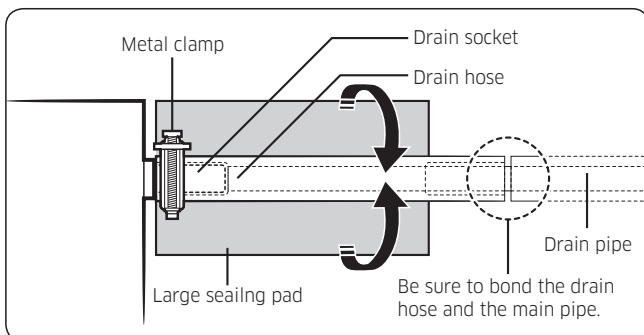

⚠ CAUTION

Check that the indoor unit is level with the ceiling by using the leveller.

- Install air ventilation to drain condensation smoothly.

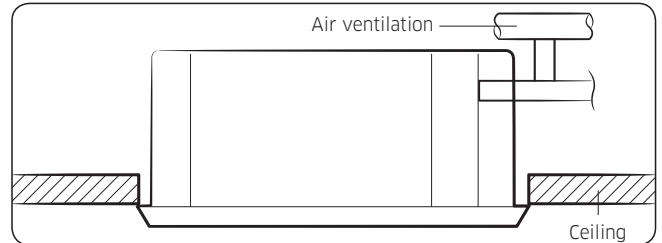

- If it is necessary to increase the height of the drain pipe, install the drain pipe straight within 300 mm from the drain hose port. If it is raised higher than 550 mm, there may be water leaks.

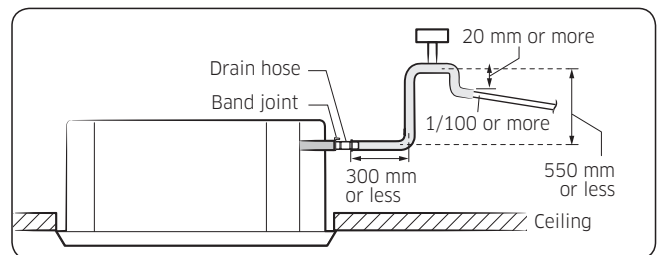

- Do not give the hose an upward gradient beyond the connection port. This will cause water to flow backwards when the unit is stopped, resulting in water leaks.

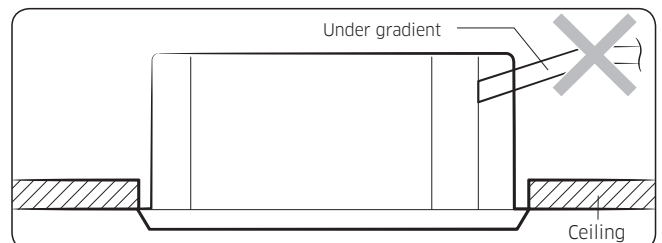

- Do not apply force to the piping on the unit side when connecting the drain hose. The hose should not be allowed to hang loose from its connection to the unit. Fasten the hose to a wall, frame or other support as close to the unit as possible.

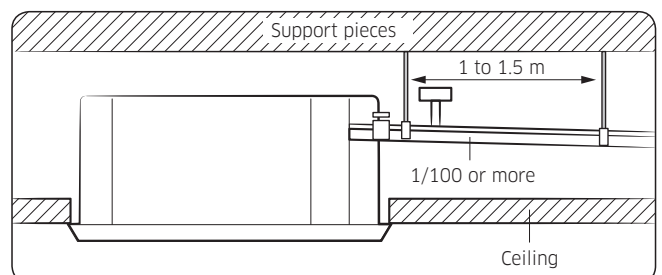

※ In case you want more information about the controllers and accessories, please refer to the Controller and Accessory TDB on pvi.Samsung.com site or Global Partner Portal site.

Installation

- Install horizontally.

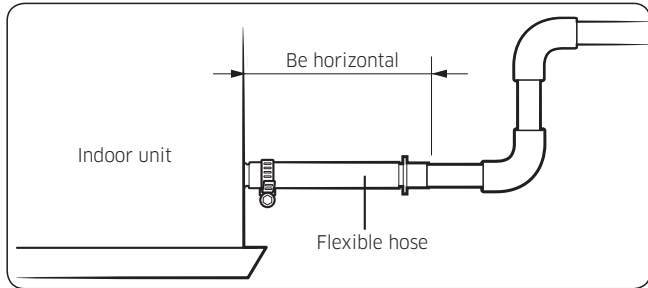

- Max. allowable axis gap.

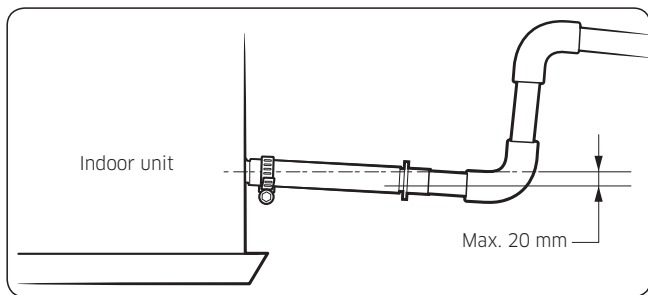

- Max. allowable bending angle.

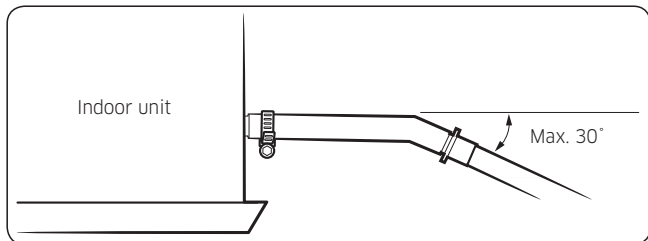

NOTE

- If a concentrated drain pipe is installed, refer to the figure below.

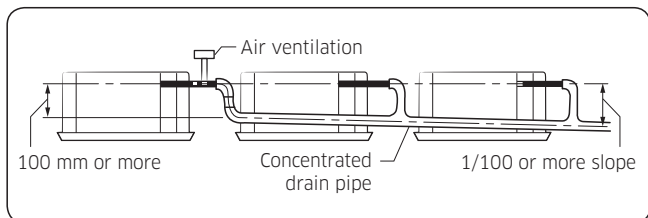

Connecting the power and communication cables

⚠ CAUTION

- Always remember to connect the refrigerant pipes before performing the electric connections. When disconnecting the system, always disconnect the electric cables before disconnecting the refrigerant pipes.
- For the product that uses the R-32 refrigerant, be cautious not to generate a spark by keeping the following requirements:
 - Do not remove the fuses with power on.
 - Do not disconnect the power plug from the wall outlet with power on.
 - It is recommended to locate the outlet in a high position. Place the cords so that they are not tangled.
- Always remember to connect the air conditioner to the grounding system before performing the electric connections. Use a crimp ring terminal at the end of each wire.

The indoor unit is powered through the outdoor unit by means of a H07 RN-F connection cable (or a more power model), with insulation in synthetic rubber and a jacket in polychloroprene (neoprene), in accordance with the requirements specified in the standard EN 60335-2-40.

- 1 Remove the screw on the electrical component box and remove the cover plate.
- 2 Route the connection cord through the side of the indoor unit and connect the cable to the terminals refer to the figure below.
- 3 Route the other end of the cable to the outdoor unit through the ceiling & the hole on the wall.
- 4 Reassemble the electrical component box cover, carefully tightening the screw.

※ In case you want more information about the controllers and accessories, please refer to the Controller and Accessory TDB on pvi.Samsung.com site or Global Partner Portal site.

Installation

1 phase

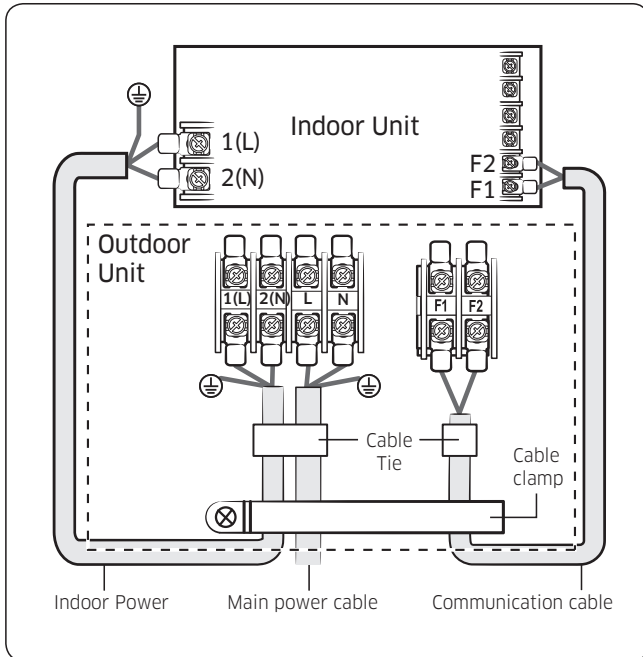

Indoor power supply		
Power supply	Max/Min(V)	Indoor power cable
220 to 240V, 50 Hz	±10%	0.75 mm ² ↑, 3 wires
Communication cable		
0.75 mm ² , 2 wires		

(Unit: mm)

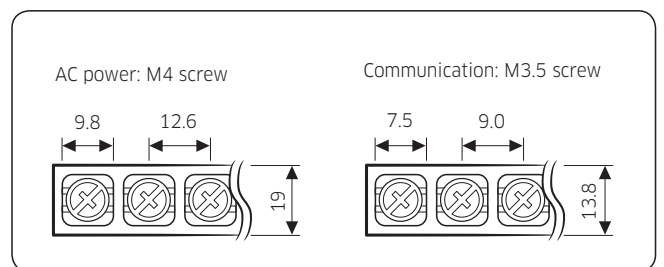

3 phase

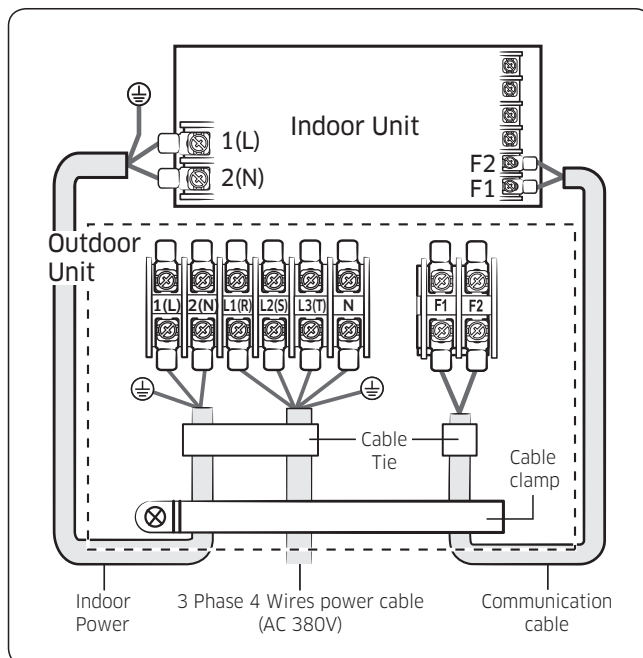

Tightening torque (kgf • cm)	
M3.5	8.0 to 12.0
M4	12.0 to 18.0

- 1 N·m = 10 kgf·cm
- Power supply cords of parts of appliances for outdoor use shall not be lighter than polychloroprene sheathed flexible cord. (Code designation IEC:60245 IEC 57 / CENELEC: H05RN-F or IEC:60245 IEC 66 / CENELEC: H07RN-F)
- Since it has the external power supply, refer to the outdoor unit installation manual for MAIN POWER.

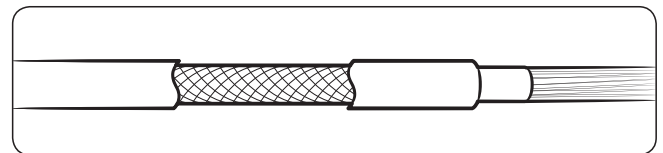

⚠ CAUTION

- When installing the indoor unit in a computer room or network room, use the double shielded communication cable (tape aluminum / polyester braid + copper) of FROHH2R type.

※ In case you want more information about the controllers and accessories, please refer to the Controller and Accessory TDB on pvi.Samsung.com site or Global Partner Portal site.

Installation

2. (Wind-Free) 4Way Cassette (600 x 600)

Spacing requirements

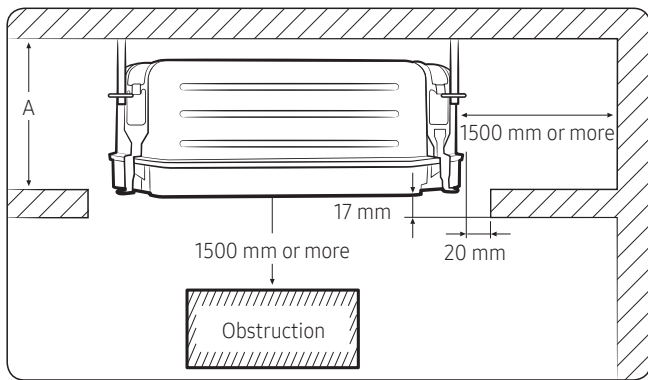

(Unit: mm)

Model	AC026RNNDKG AC035RNNDKG AC052RNNDKG AC071RNNDKG
A	297

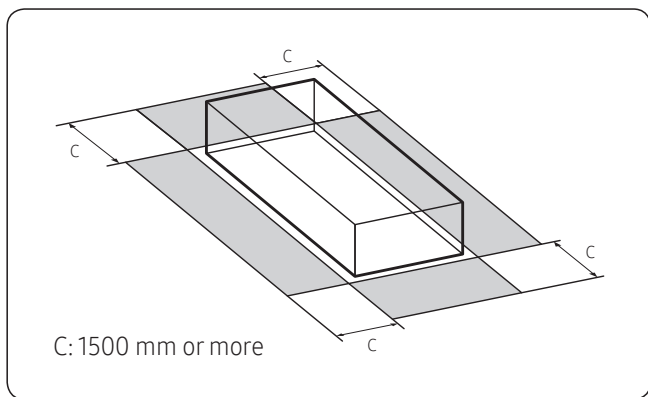

⚠ CAUTION

- The indoor unit must be installed according to the specified distances in order to permit accessibility from each side, to guarantee correct operation, maintenance, and repair of the unit. The components of the indoor unit must be reachable and removable under safe conditions for people and the unit.
- Do not hold the discharge while carrying the indoor unit to avoid the possibility of breakage.

- You must hold the hanger plate on the corner and carry the indoor unit.

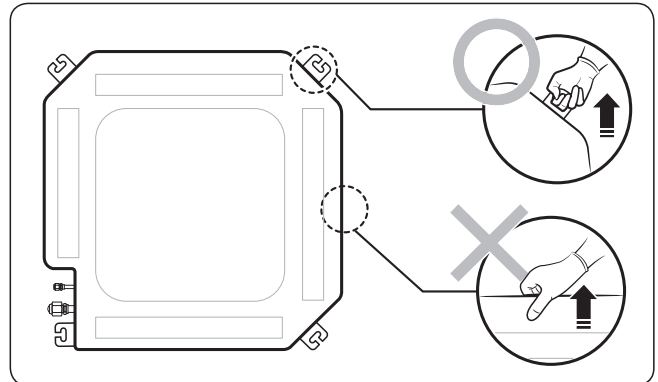

Optional: Insulating the body of the indoor unit

If you install a cassette type indoor unit on the ceiling when temperature is over 27°C and humidity is over 80%, you must apply an extra 10 mm thick polyethylene insulation or a similar type of insulation to the body of the indoor unit.

Cut away the part where pipes are pulled out for the insulating work.

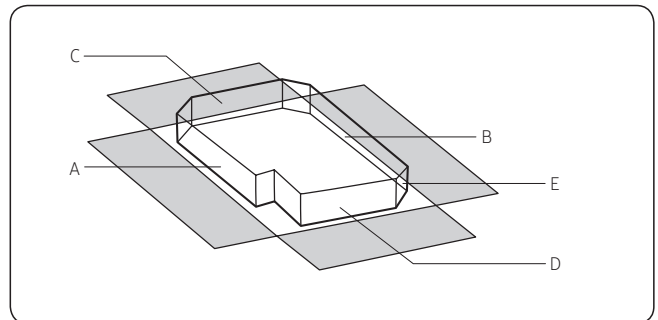

Insulate the end of the pipe and some curved area by using separate insulator.

📄 NOTE

- A: Reference for the outer circumference of the unit (When insulating the body of the indoor unit, use A as the reference for its outer circumference.)

(Unit: mm)

A	B	C	D	E
400X190	400X190	400X190	400X190	550X550

※ In case you want more information about the controllers and accessories, please refer to the Controller and Accessory TDB on pvi.Samsung.com site or Global Partner Portal site.

Installation

Installing the indoor unit

When deciding on the location of the air conditioner the following restrictions must be taken into account.

- 1 Place the pattern sheet on the ceiling at the spot where you want to install the indoor unit.

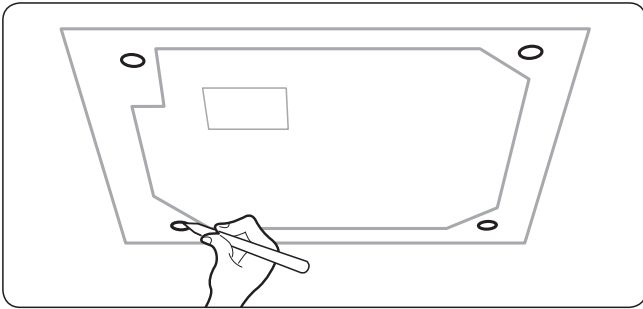

NOTE

- Since the diagram is made of paper, it may shrink or stretch slightly due to temperature or humidity. For this reason, before drilling the holes, be sure to maintain the correct dimensions between the markings.

- 2 Insert bolt anchors, use existing ceiling supports or construct a suitable support as shown in figure.

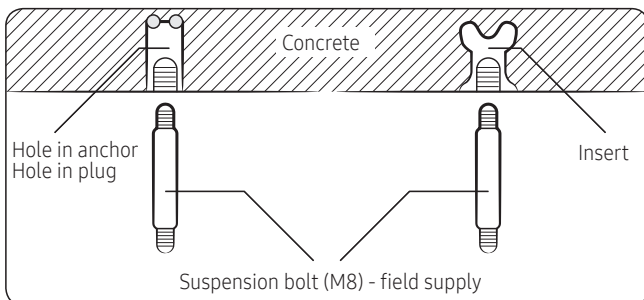

- 3 Install the suspension bolts, depending on the ceiling type.

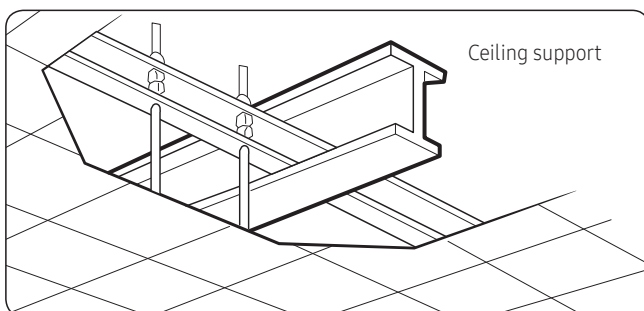

CAUTION

- Make sure that the ceiling is strong enough to support the weight of the indoor unit. Before hanging the unit, test the strength of each attached suspension bolt.
- If the length of the suspension bolt is more than 1.5 m, you are required to prevent vibration.

- 4 Screw eight pairs of nuts and washers to the suspension bolts, making space for hanging the indoor unit.

CAUTION

- You must install all of the suspension rods.
- It is important to leave sufficient space in the false ceiling to allow access for maintenance or repairs to the drainage pipe connection, the refrigerant pipe connection, or to remove the unit if necessary.

- 5 Hang the indoor unit to the suspension bolts between two nuts. Cut a pad stopper and place it on the suspension bolts to hold the washer. Remove the stopper and screw the nuts to fix the unit.

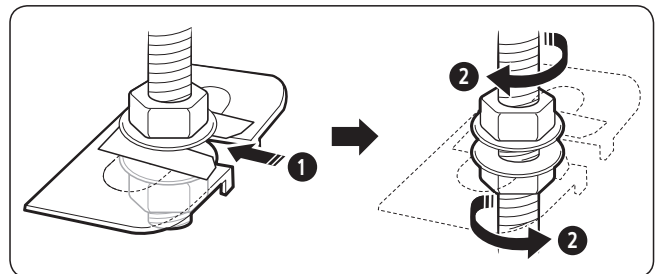

- 6 Adjust the unit to the appropriate position, taking into account the installation area for the front panel.

- Place the pattern sheet on the indoor unit.
- Adjust the space between the ceiling and the indoor unit by using a dimension gauge.
- Fix the indoor unit securely after adjusting the level of the unit by using a leveller.
- Remove the pattern sheet, connect the other cables, and install the front panel.

※ In case you want more information about the controllers and accessories, please refer to the Controller and Accessory TDB on pvi.Samsung.com site or Global Partner Portal site.

Installation

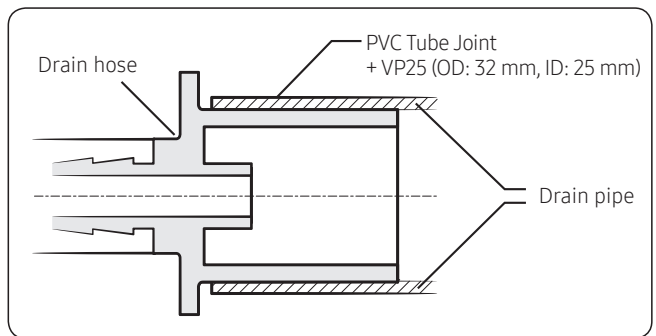
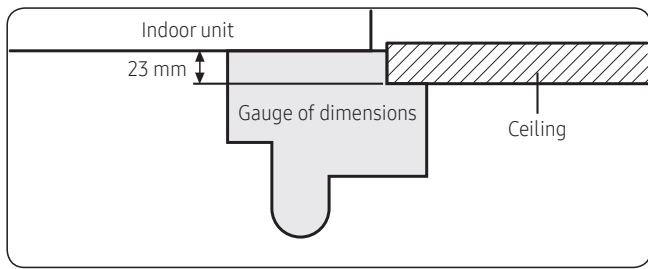

Installing the drain hose and drain pipe

- 1 Push the supplied drain hose as far as possible over the drain socket.
- 2 Tighten the metal clamp as shown in the picture.

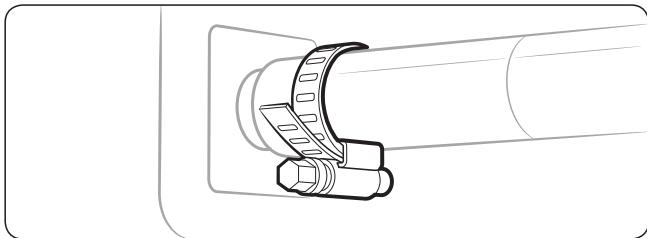

- 3 Wrap the supplied large sealing pad over the metal clamp and drain hose to insulate and fix it with clamps.
- 4 Insulate the complete drain piping inside the building (field supply).
If the drain hose cannot be sufficiently set on a slope, fit the hose with drain raising piping (field supply).
- 5 Push the drain hose up to insulation when connecting the drain hose to drain socket.

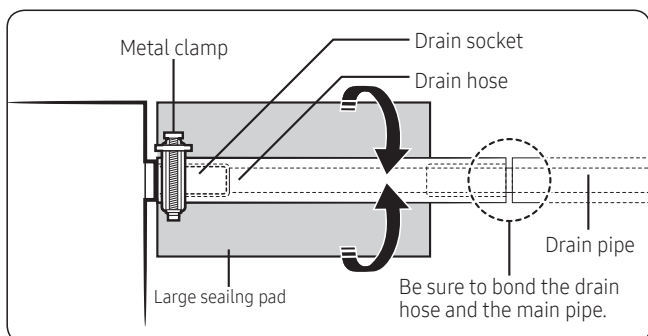

⚠ CAUTION

Check that the indoor unit is level with the ceiling by using the leveller.

- Install air ventilation to drain condensation smoothly.

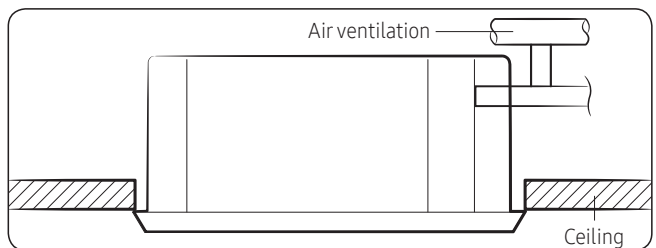

- If it is necessary to increase the height of the drain pipe, install the drain pipe straight within 300 mm from the drain hose port. If it is raised higher than 550 mm, there may be water leaks.

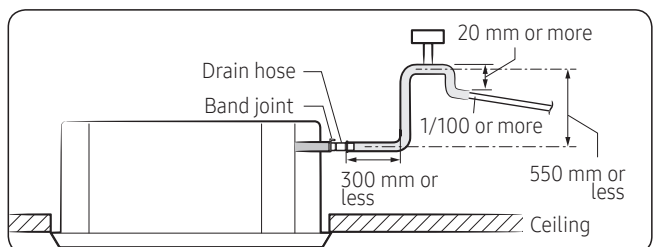

- Do not give the hose an upward gradient beyond the connection port. This will cause water to flow backwards when the unit is stopped, resulting in water leaks.

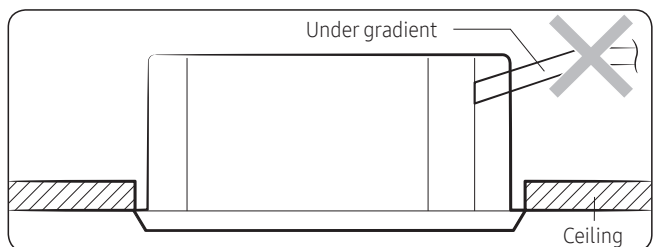

※ In case you want more information about the controllers and accessories, please refer to the Controller and Accessory TDB on pvi.Samsung.com site or Global Partner Portal site.

Installation

- Do not apply force to the piping on the unit side when connecting the drain hose. The hose should not be allowed to hang loose from its connection to the unit. Fasten the hose to a wall, frame or other support as close to the unit as possible.

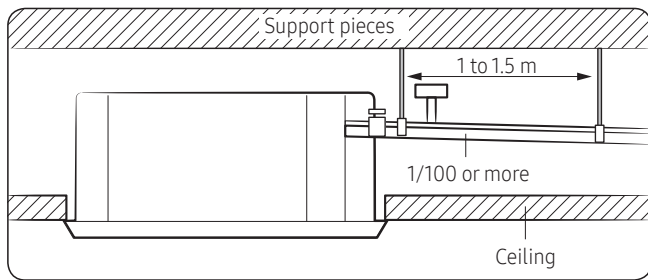

- Install horizontally.

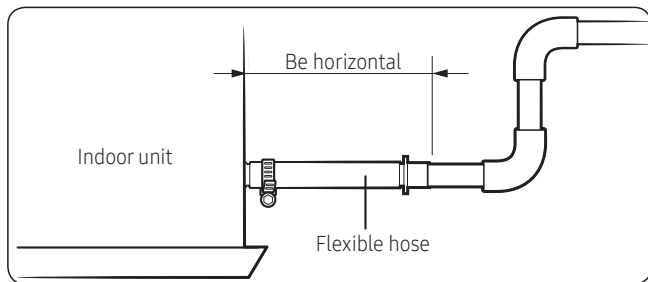

- Max. allowable axis gap.

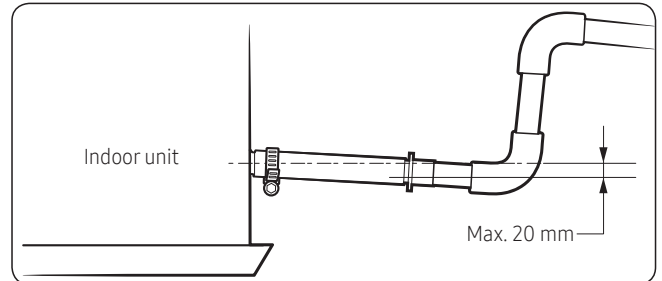

- Max. allowable bending angle.

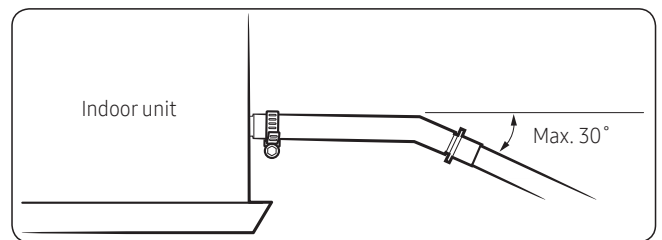

NOTE

- If a concentrated drain pipe is installed, refer to the figure below.

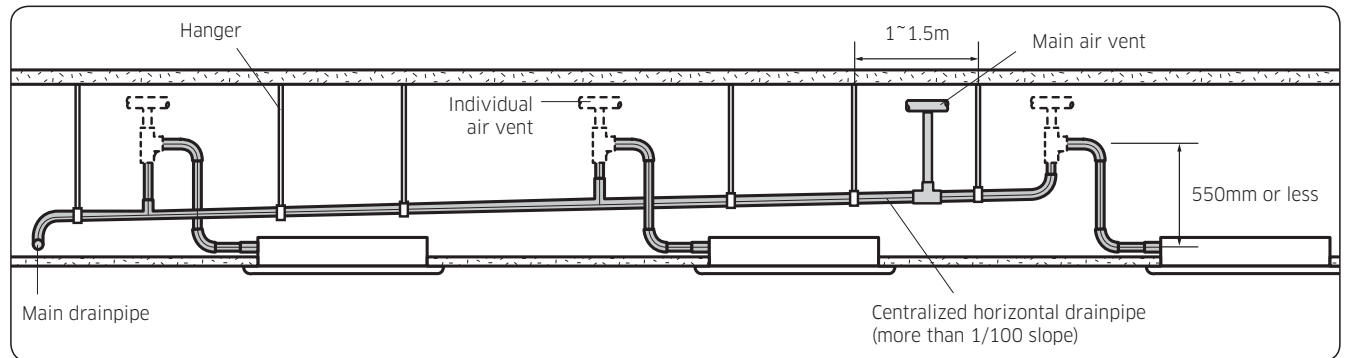

※ In case you want more information about the controllers and accessories, please refer to the Controller and Accessory TDB on pvi.Samsung.com site or Global Partner Portal site.

Installation

Connecting the power and communication cables

⚠ CAUTION

- Always remember to connect the refrigerant pipes before performing the electric connections. When disconnecting the system, always disconnect the electric cables before disconnecting the refrigerant pipes.

⚠ CAUTION

- Always remember to connect the air conditioner to the grounding system before performing the electric connections. Use a crimp ring terminal at the end of each wire.

The indoor unit is powered through the outdoor unit by means of a H07 RN-F connection cable (or a more power model), with insulation in synthetic rubber and a jacket in polychloroprene (neoprene), in accordance with the requirements specified in the standard EN 60335-2-40.

- 1 Remove the screw on the electrical component box and remove the cover plate.
- 2 Route the connection cord through the side of the indoor unit and connect the cable to the terminals refer to the figure below.
- 3 Route the other end of the cable to the outdoor unit through the ceiling & the hole on the wall.
- 4 Reassemble the electrical component box cover, carefully tightening the screw.

1 phase

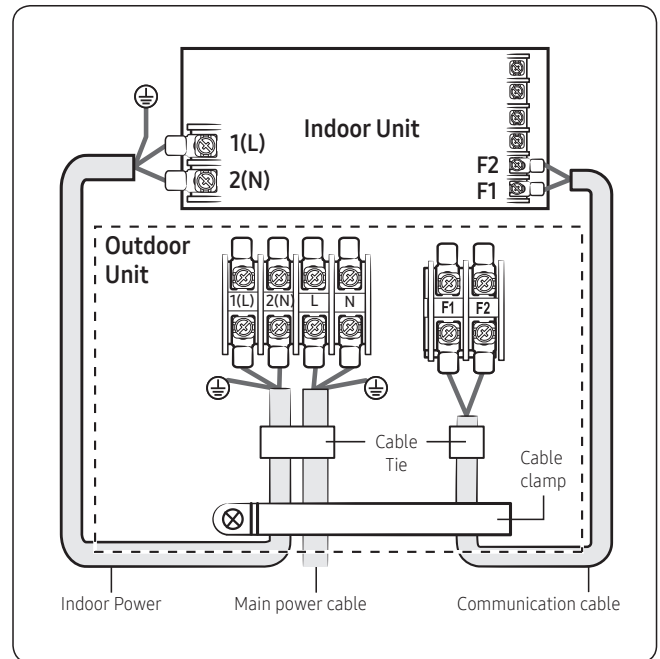

Indoor power supply		
Power supply	Max/Min(V)	Indoor power cable
220 to 240V, 50 Hz	±10%	0.75 mm ² , 3 wires
Communication cable		
0.75 mm ² , 2 wires		

※ In case you want more information about the controllers and accessories, please refer to the Controller and Accessory TDB on pvi.Samsung.com site or Global Partner Portal site.

Installation

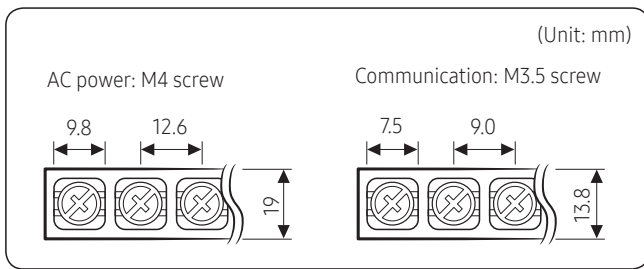

Tightening torque (N • m)	
M3.5	0.8 to 1.2
M4	1.2 to 1.8

- 1 N·m = 10 kgf·cm
- Power supply cords of parts of appliances for outdoor use shall not be lighter than polychloroprene sheathed flexible cord. (Code designation IEC:60245 IEC 57 / CENELEC: H05RN-F or IEC:60245 IEC 66 / CENELEC: H07RN-F)
- Since it has the external power supply, refer to the outdoor unit installation manual for MAIN POWER.

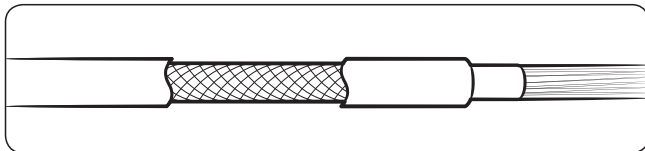

⚠ CAUTION

- When installing the indoor unit in a computer room or network room, use the double shielded communication cable (tape aluminum / polyester braid + copper) of FROHH2R type.
- Select the power cable in accordance with relevant local and national.
- Wire size must comply with local and national code.
- You should connect the power cable into the power cable terminal and fasten it with a clamp.
- The unbalanced power must be maintained within 10% of supply rating among whole indoor units.
- If the power is unbalanced greatly, it may shorten the life of the condenser. If the unbalanced power is exceeded over 10% of supply rating, the indoor unit is protected, stopped and the error mode indicates
- Connect the power cable to the auxiliary circuit breaker. An all pole disconnection from the power supply must be incorporated in the fixed wiring ($\geq 3\text{mm}$).
- You must keep the cable in a protection tube.
- Maximum length of power cables are decided within 10% of power drop. If it exceeds, you must consider another power supplying method.
- The circuit breaker (MCCB, ELB) should be considered more capacity if many indoor units are connected from one breaker.
- Use round pressure terminal for connections to the power terminal block.
- For wiring, use the designated power cable and connect it firmly, then secure to prevent outside pressure being exerted on the terminal board.
- Use an appropriate screwdriver for tightening the terminal screws. A screwdriver with a small head will strip the head and make proper tightening impossible.
- Over-tightening the terminal screws may break them.

※ In case you want more information about the controllers and accessories, please refer to the Controller and Accessory TDB on pvi.Samsung.com site or Global Partner Portal site.

Installation

3. 360 Cassette

Spacing requirements

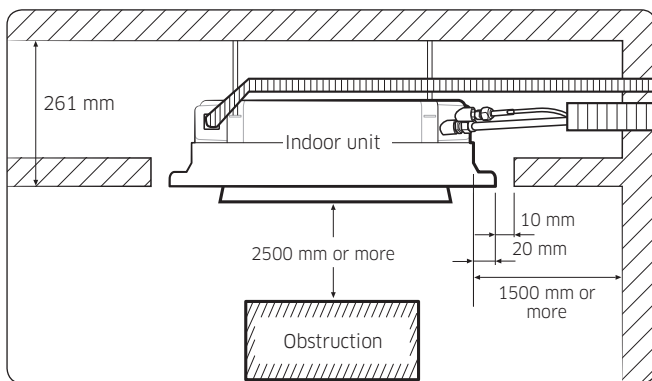
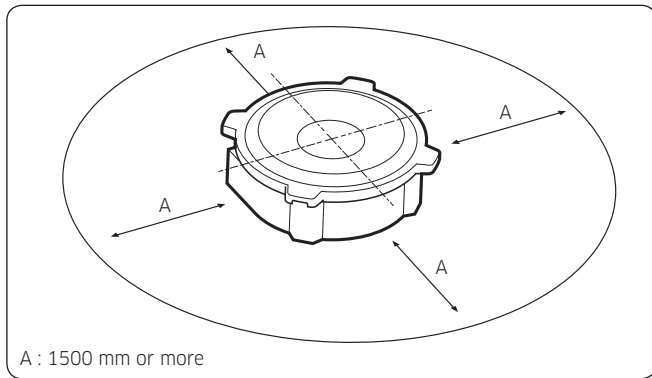

⚠ CAUTION

- Comply with the length and height limits described in the figure above.
- For the product that uses the R-32 refrigerant, install the indoor unit on the wall 1.8 m or higher from the floor.
- The indoor unit must be installed according to the specified distances in order to permit accessibility from each side, to guarantee correct operation, maintenance, and repair of the unit. The components of the indoor unit must be reachable and removable under safe conditions for people and the unit.
- Do not hold the discharge while carrying the indoor unit to avoid the possibility of breakage.
- You must hold the hanger plate on the corner and carry the indoor unit.

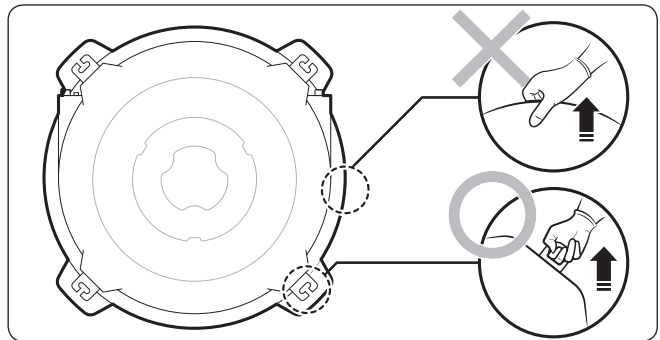

Optional: Insulating the body of the indoor unit

If you install a cassette type indoor unit on the ceiling when temperature is over 27°C and humidity is over 80%, you must apply an extra 10 mm thick polyethylene insulation or a similar type of insulation to the body of the indoor unit.

Cut away the part where pipes are pulled out for the insulating work.

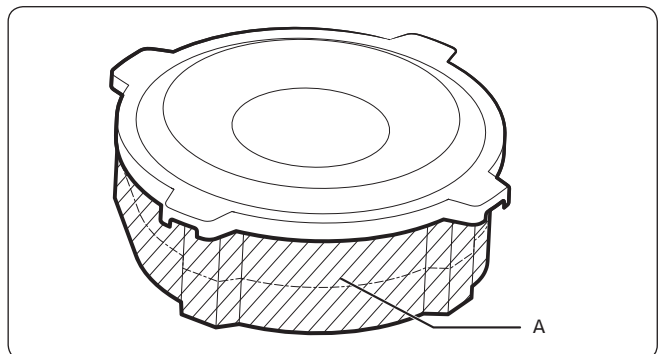

Insulate the end of the pipe and some curved area by using separate insulator.

📖 NOTE

- A: Reference for the outer circumference of the unit (When insulating the body of the indoor unit, use A as the reference for its outer circumference.)

(Unit: mm)

Indoor unit type and models		Dimensions
360 cassette type <S> (947 x 947 x 281)	AC071RN4PKG	2610 x 130

※ In case you want more information about the controllers and accessories, please refer to the Controller and Accessory TDB on pvi.Samsung.com site or Global Partner Portal site.

Installation

Installing the indoor unit

When deciding on the location of the air conditioner the following restrictions must be taken into account.

- 1 Determine the positions of the pipe and the drain hose hole as shown in the pattern sheet, and drill the hole with an inner diameter of 14 mm.

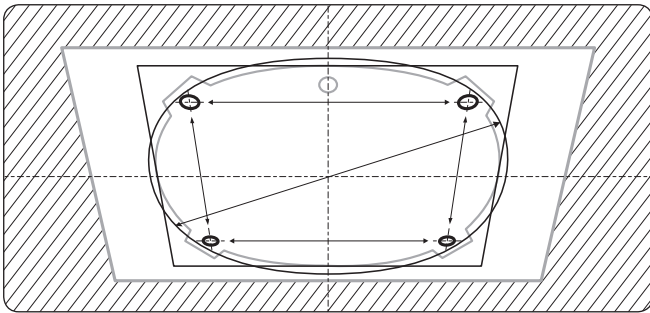

NOTE

- Since the diagram is made of paper, it may shrink or stretch slightly due to temperature or humidity. For this reason, before drilling the holes, be sure to maintain the correct dimensions between the markings.
- 2 Perform the following steps to install inspection holes in accordance with the panel type.
 - a For the recessed installation of the square panel.
 - Install an inspection hole to the direction of connection parts of the refrigerant pipe and the drain hose. (1 point)

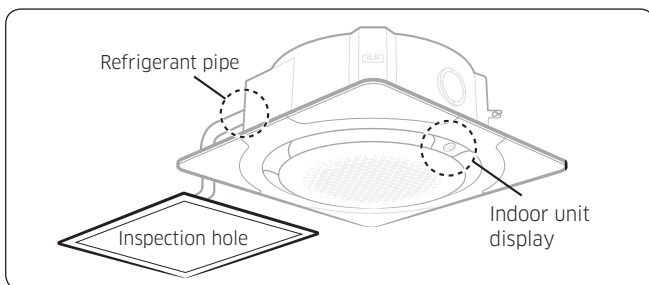

- b For recessed installation of the circular panel
 - Install inspection holes to both directions of the connection part of the refrigerant pipe and the drain hose and of the indoor unit display. (2 points)

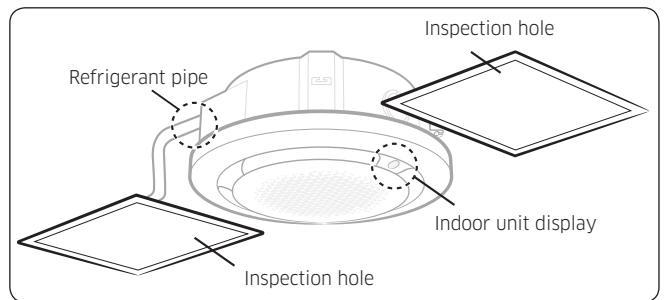

- 3 Insert bolt anchors, use existing ceiling supports or construct a suitable support as shown in figure.

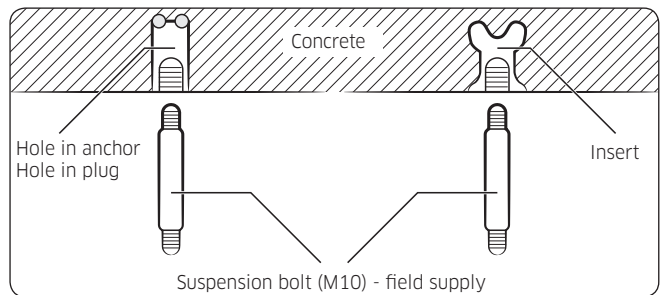

- 4 Install the suspension bolts, depending on the ceiling type.

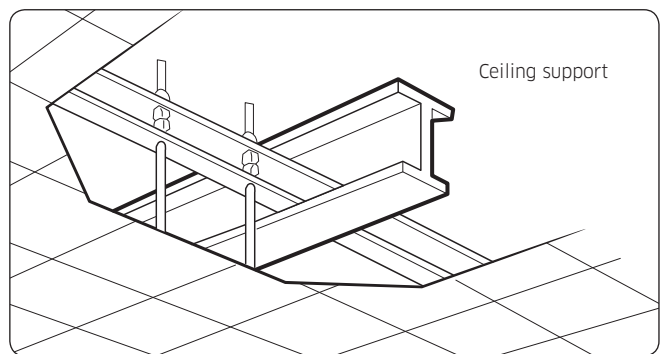

CAUTION

- Make sure that the ceiling is strong enough to support the weight of the indoor unit. Before hanging the unit, test the strength of each attached suspension bolt.

※ In case you want more information about the controllers and accessories, please refer to the Controller and Accessory TDB on pvi.Samsung.com site or Global Partner Portal site.

Installation

- If the length of the suspension bolt is more than 1.5 m, you are required to prevent vibration.
- 5 Screw eight pairs of nuts and washers to the suspension bolts, making space for hanging the indoor unit.

⚠ CAUTION

- You must install all of the suspension rods.
- It is important to leave sufficient space in the false ceiling to allow access for maintenance or repairs to the drainage pipe connection, the refrigerant pipe connection, or to remove the unit if necessary.
- 6 Hang the indoor unit to the suspension bolts between two nuts. Cut a pad stopper and place it on the suspension bolts to hold the washers. Remove the stopper and screw the nuts to fix the unit.

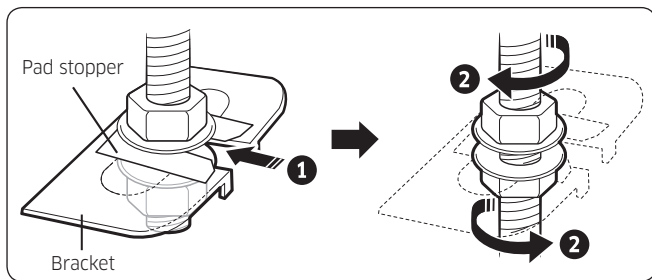

- 7 Adjust the unit to the appropriate position, taking into account the installation area for the front panel.
 - Place the pattern sheet on the indoor unit.
 - Adjust the space between the ceiling and the indoor unit by using a dimension gauge.
 - Fix the indoor unit securely after adjusting the level of the unit by using a leveller.
 - Remove the pattern sheet, connect the other cables, and install the front panel.

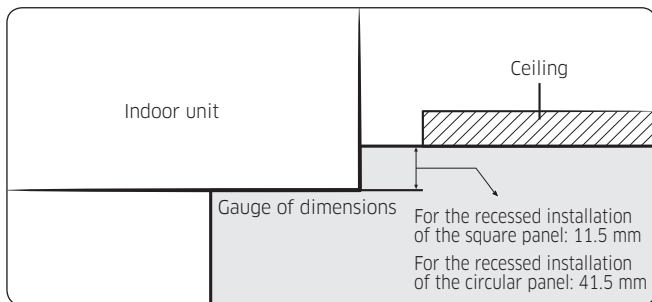

Installing the drain hose and drain pipe

- 1 Push the supplied drain hose as far as possible over the drain socket.
- 2 Tighten the metal clamp as shown in the picture.

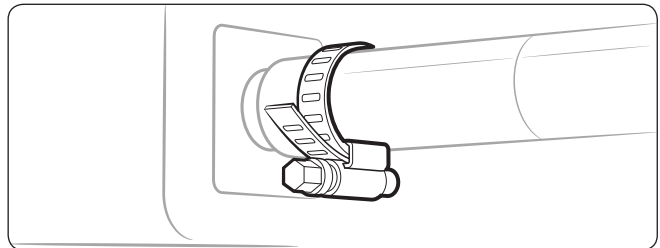

- 3 Wrap the supplied large sealing pad over the metal clamp and drain hose to insulate and fix it with clamps.
- 4 Insulate the complete drain piping inside the building (field supply).
If the drain hose cannot be sufficiently set on a slope, fit the hose with drain raising piping (field supply).
- 5 Push the drain hose up to insulation when connecting the drain hose to drain socket.

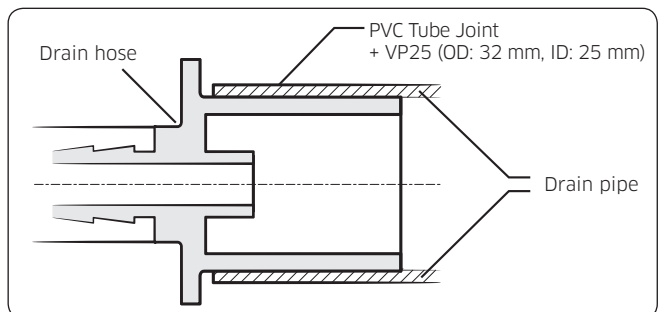
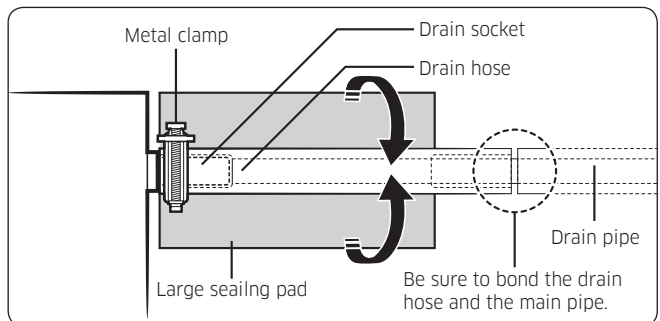

※ In case you want more information about the controllers and accessories, please refer to the Controller and Accessory TDB on pvi.Samsung.com site or Global Partner Portal site.

Installation

⚠ CAUTION

Check that the indoor unit is level with the ceiling by using the leveller.

- Install air ventilation to drain condensation smoothly.

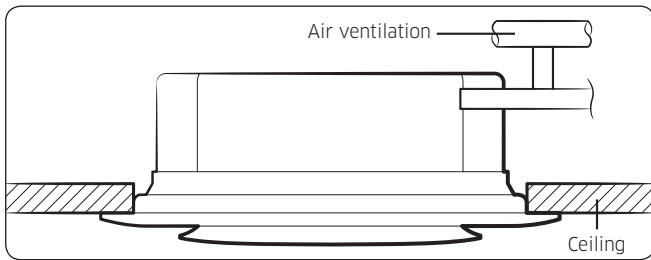

- If it is necessary to increase the height of the drain pipe, install the drain pipe straight within 300 mm from the drain hose port. If it is raised higher than 550 mm, there may be water leaks.

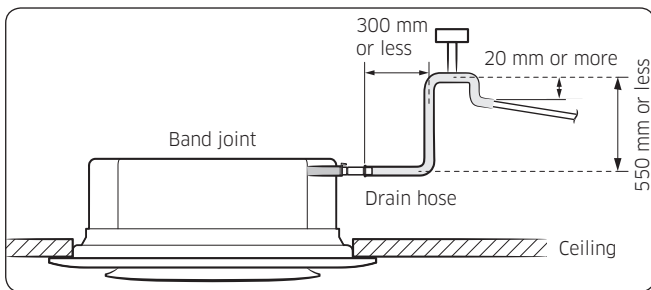

- Do not give the hose an upward gradient beyond the connection port. This will cause water to flow backwards when the unit is stopped, resulting in water leaks.

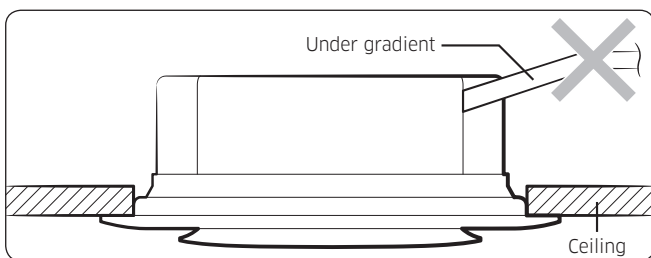

- Do not apply force to the piping on the unit side when connecting the drain hose. The hose should not be allowed to hang loose from its connection to the unit. Fasten the hose to a wall, frame or other support as close to the unit as possible.

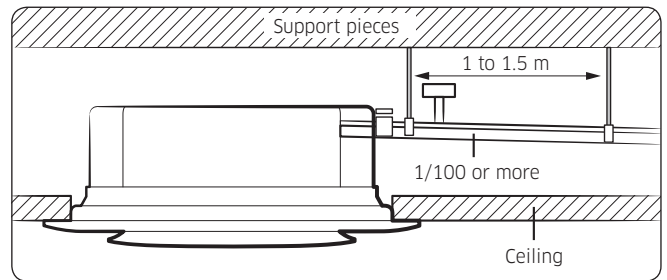

- Install horizontally.

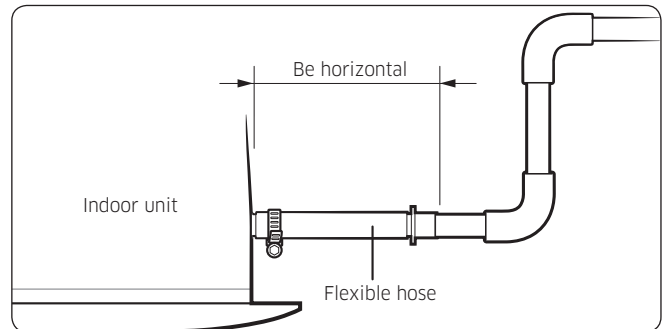

- Max. allowable axis gap.

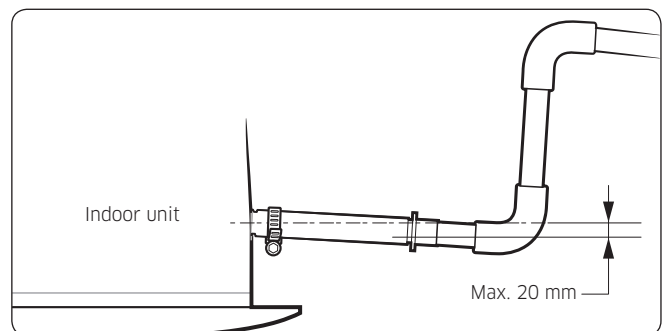

※ In case you want more information about the controllers and accessories, please refer to the Controller and Accessory TDB on pvi.Samsung.com site or Global Partner Portal site.

Installation

- Max. allowable bending angle.

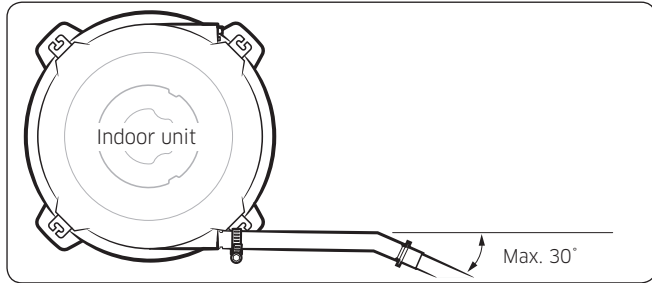

NOTE

- If a concentrated drain pipe is installed, refer to the figure below.

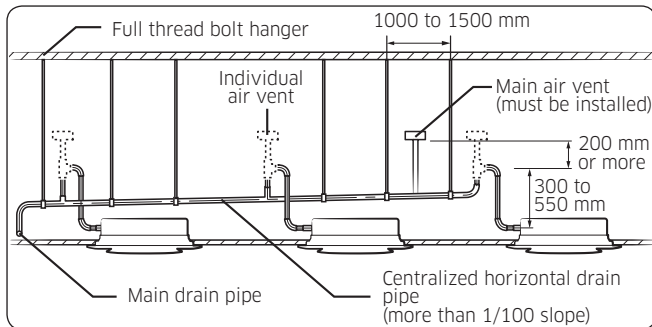

Optional: For the installation of the circular panel

Making a circular opening on the ceiling

Use a paper compass printed on the indoor unit package. (attached inside to the upper part)

- 1 Use a bolt or a pin to fix pivot point of the paper compass on center of the ceiling. (in the middle of location for installation)

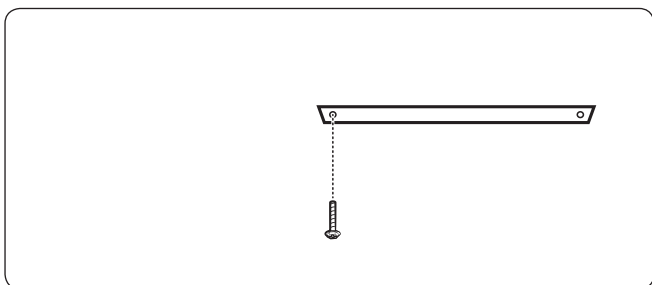

- 2 Put a pencil at the opposite side of the pivot point fixed in place.

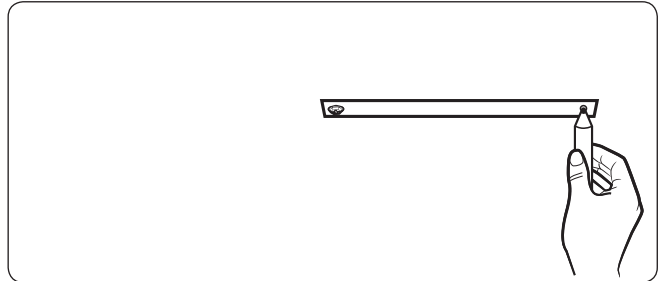

- 3 Rotate the paper compass on its pivot point to draw a line on the ceiling.

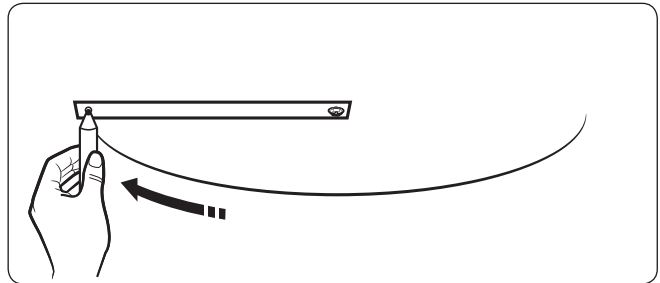

- 4 Rotate the paper compass diametrically to draw a circle on the ceiling.

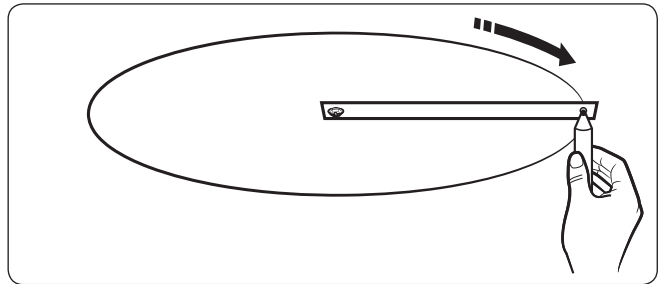

For the painting of the panel

- Make sure to only apply paints and varnishes for resins (ABS, HIPS) or paint thinners.
- If you apply lacquers for general use on the panel, it may lead to discoloration or erosion on the surface of the panel.

※ In case you want more information about the controllers and accessories, please refer to the Controller and Accessory TDB on pvi.Samsung.com site or Global Partner Portal site.

Installation

4. Duct Type

Space requirements for installation

Construction Standard for Inspection Hole

- 1 In case, the ceiling is tex tile, Inspection hole dose not need.
- 2 In case, the ceiling is plaster board, Inspection hole depends on Inside height of the ceiling.
 - a Height is more than 0.5m : Only "B" [Inspection for PBA] is applied.
 - b Height is less than 0.5m : Both "A"&"B" are applied.
 - c "A"&"B" are inspection holes .

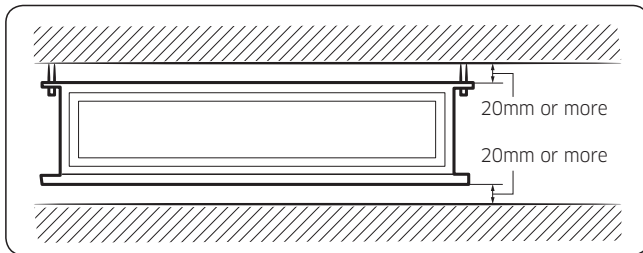
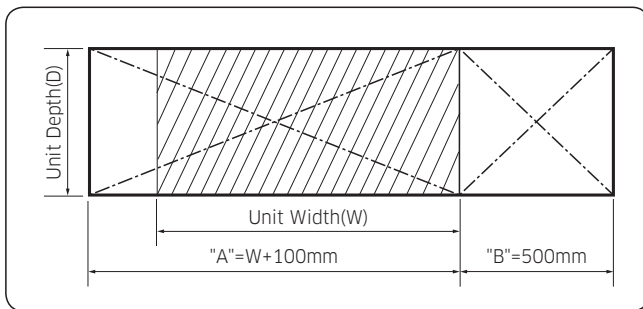

- You must have 20 mm or more space between the ceiling and the bottom of indoor unit. Otherwise, the noise from the vibration of indoor unit may bother the user. When the ceiling is under construction, the hole for check-up must be made to take service, clean and repair the unit.
- It is possible to install the unit at an height of between 2.2~2.5 m from the ground, if the unit has a duct with a well defined lenght (300 mm or more), to avoid fan motor blower contact.
- If you install the cassette or duct type indoor unit on the ceiling with humidity over 80%, you must apply extra 10 mm of polyethylene foam or other insulation with similar material on the body of the indoor unit.

Optional: Insulating the body of the indoor unit

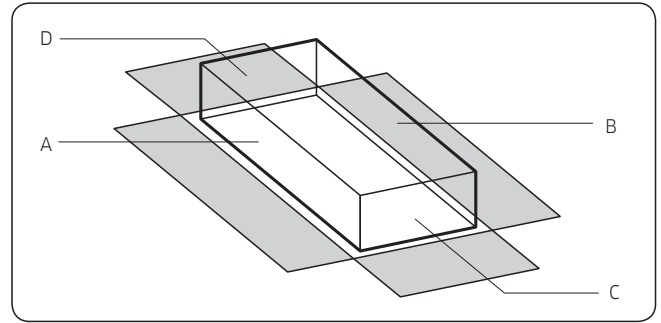

Thickness: more than 10mm

Indoor Unit	AC026RNLDKG AC035RNLDKG	AC052RNLDKG AC071RNLDKG	AC035RNMDKG AC052RNMDKG AC071RNMDKG
		700 X 600 X 199	1100 X 450 X 200
A	700 X 199	1100 X 200	850 X 250
B	700 X 199	1100 X 200	850 X 250
C	600 X 199	450 X 200	700 X 250
D	600 X 199	450 X 200	700 X 250
Front / Back	Insulate the front and back side in proper size at the same time when insulating the suction duct and discharge duct.		

(Unit: mm)

NOTE

- Insulate the end of the pipe and some curved area by using separate insulator.
- Insulate the discharge and suction part at the same time when you insulate connection duct.

※ In case you want more information about the controllers and accessories, please refer to the Controller and Accessory TDB on pvi.Samsung.com site or Global Partner Portal site.

Installation

Installing the indoor unit

When deciding on the location of the air conditioner with the owner, the following restrictions must be taken into account

- 1 Place the pattern sheet on the ceiling at the spot where you want to install the indoor unit.

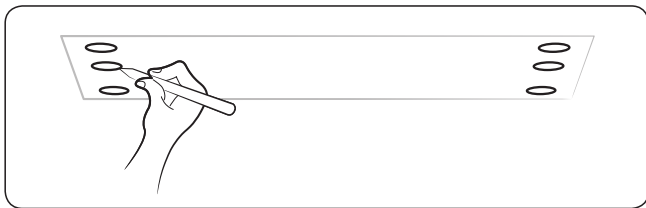

NOTE

- Since the diagram is made of paper, it may shrink or stretch slightly due to temperature or humidity. For this reason, before drilling the holes maintain the correct dimensions between the markings.

- 2 Insert bolt anchors. Use existing ceiling supports or construct a suitable support as shown in figure.

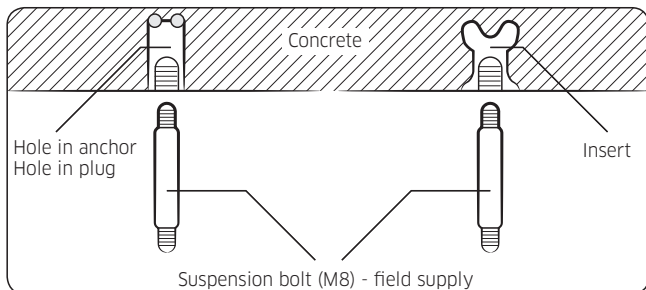

- 3 Install the suspension bolts depending on the ceiling type.

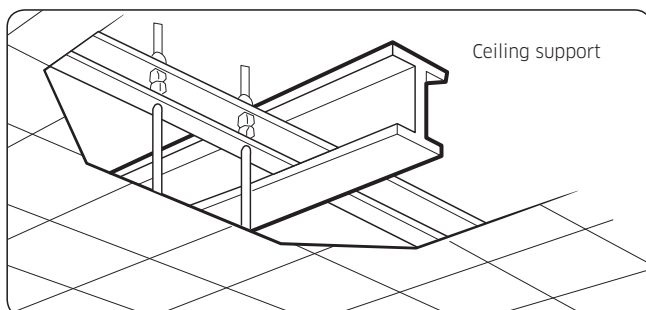

CAUTION

- Ensure that the ceiling is strong enough to support the weight of the indoor unit. Before hanging the unit, test the strength of each attached suspension bolt.
 - If the length of suspension bolt is more than 1.5m, it is required to prevent vibration.
 - If this is not possible, create an opening on the false ceiling in order to be able to use it to perform the required operations on the indoor unit.
- 4 Screw eight nuts to the suspension bolts making space for hanging the indoor unit.

NOTE

- You must install all the suspension rods.
- 5 Hang the indoor unit to the suspension bolts between two nuts.

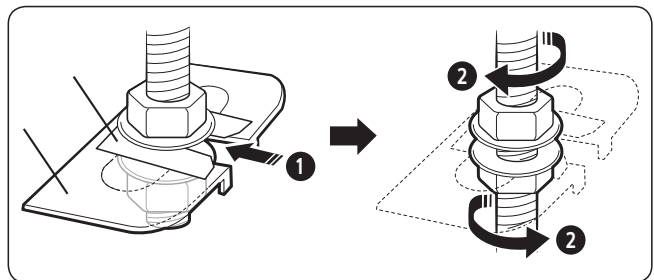

CAUTION

- Piping must be laid and connected inside the ceiling when suspending the unit. If the ceiling is already constructed, lay the piping into position for connection to the unit before placing the unit inside the ceiling.

- 6 Screw the nuts to suspend the unit.
- 7 Adjust level of the unit by using measurement plate for all 4 sides.

CAUTION

- For proper drainage of condensate, give a 3mm slant to the left or right side of the unit which will be connected with the drain hose, as shown in the figure. Make a tilt when you wish to install the drain pump, too.

※ In case you want more information about the controllers and accessories, please refer to the Controller and Accessory TDB on pvi.Samsung.com site or Global Partner Portal site.

Installation

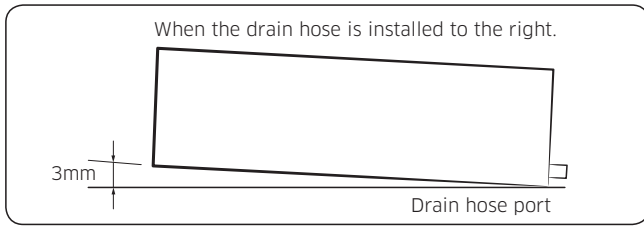

- When installing the indoor unit, make sure it is not tilted toward front or back side.

⚠ CAUTION

- Noise will increase 3~6 dB(A) when the air flow enters from the bottom side (Only for Slim Duct Type product).

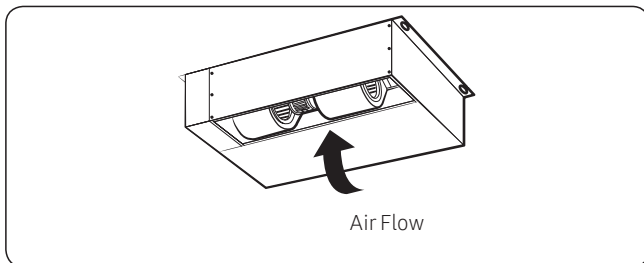

Installing the drain hose and drain pipe

- 1 Push the supplied drain hose as far as possible over the drain socket.
- 2 Tighten the metal clamp as shown in the picture.

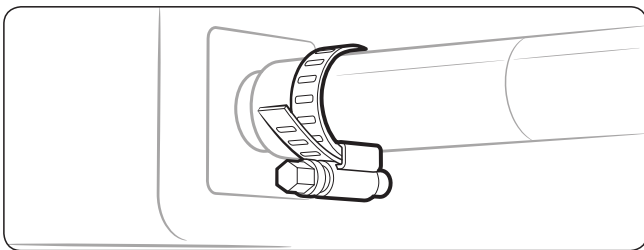

- 3 Wrap the supplied large sealing pad over the metal clamp and drain hose to insulate and fix it with clamps.
- 4 Insulate the complete drain piping inside the building (field supply).
If the drain hose cannot be sufficiently set on a slope, fit the hose with drain raising piping (field supply).

- 5 Push the drain hose up to insulation when connecting the drain hose to drain socket.

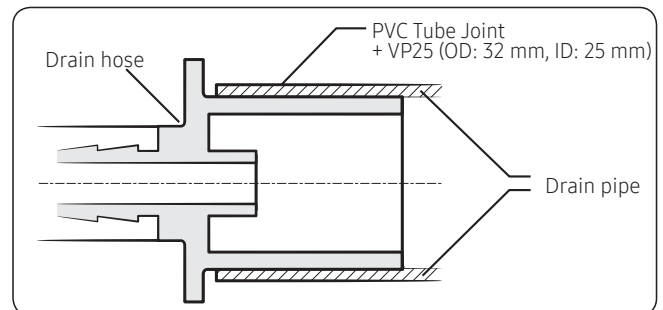
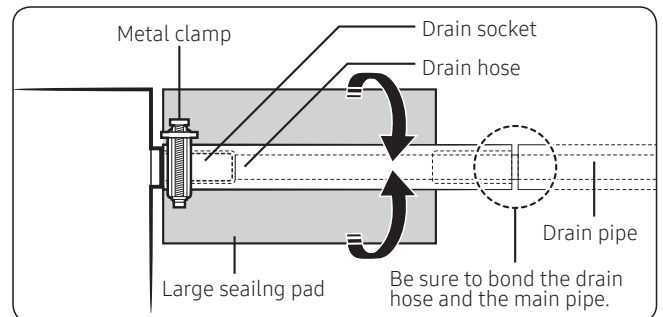

Without the drain pump

- 1 Install horizontal drainpipe with a slope of 1/100 or more and fix it by hanger space of 1.0~1.5 m.
- 2 Install U-trap at the end of the drainpipe to prevent a nasty smell to reach the indoor unit.
- 3 Do not install the drainpipe to upward position. It may cause water flow back to the unit.

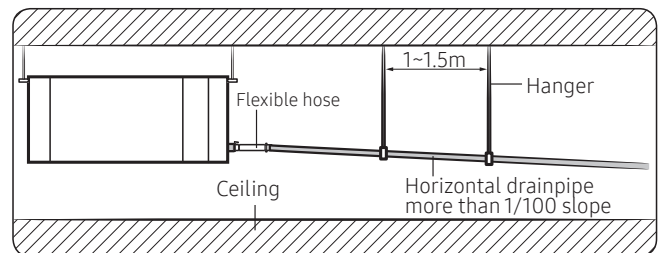

※ In case you want more information about the controllers and accessories, please refer to the Controller and Accessory TDB on pvi.Samsung.com site or Global Partner Portal site.

Installation

With the drain pump

- 1 The drain pipe should be installed within 300mm to 550mm from the flexible hose and then lift down 20mm or more.
- 2 Install horizontal drainpipe with a slope of 1/100 or more and fix it by hanger space of 1.0~1.5m.
- 3 Install the air vent in the horizontal drainpipe to prevent water flow back to the indoor unit.

NOTE

- You may not need to install it if there were proper slope in the horizontal drainpipe.
- 4 The flexible hose should not be installed upward position, it may cause water flow back to the indoor unit.

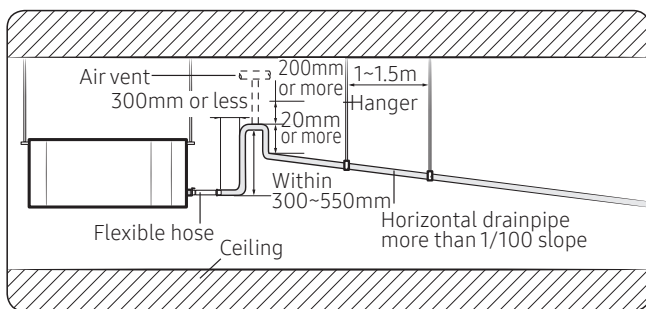

Connecting the power and communication cables

CAUTION

- Always remember to connect the refrigerant pipes before performing the electric connections. When disconnecting the system, always disconnect the electric cables before disconnecting the refrigerant pipes.

CAUTION

- Always remember to connect the air conditioner to the grounding system before performing the electric connections. Use a crimp ring terminal at the end of each wire.

The indoor unit is powered through the outdoor unit by means of a H07 RN-F connection cable (or a more power model), with insulation in synthetic rubber and a jacket in polychloroprene (neoprene), in accordance with the requirements specified in the standard EN 60335-2-40.

- 1 Remove the screw on the electrical component box and remove the cover plate.
- 2 Route the connection cord through the side of the indoor unit and connect the cable to the terminals refer to the figure below.
- 3 Route the other end of the cable to the outdoor unit through the ceiling & the hole on the wall.
- 4 Reassemble the electrical component box cover, carefully tightening the screw.

1 phase (**026/035/052/071**)

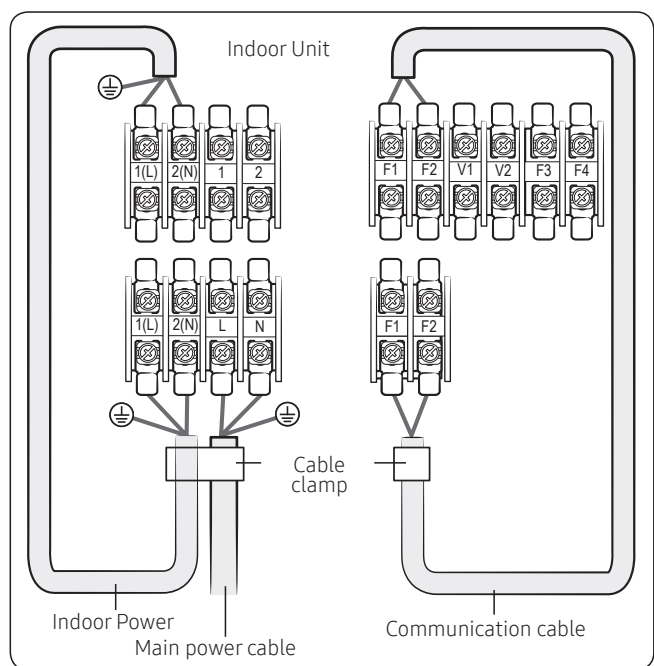

※ In case you want more information about the controllers and accessories, please refer to the Controller and Accessory TDB on pvi.Samsung.com site or Global Partner Portal site.

Installation

Indoor power supply		
Power supply	Max/Min(V)	Indoor power cable
220 to 240V, 50 Hz	±10%	0.75 to 1.5 mm ² , 3 wires
Communication cable		
0.75 mm ² , 2 wires		

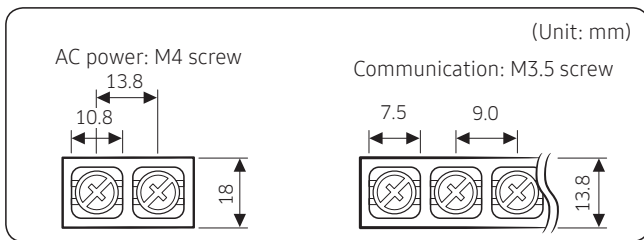

Tightening torque (kgf • cm)	
M3.5	8.0 to 12.0
M4	12.0 to 18.0

- 1 N·m = 10 kgf·cm
- Power supply cords of parts of appliances for outdoor use shall not be lighter than polychloroprene sheathed flexible cord. (Code designation IEC:60245 IEC 57 / CENELEC: H05RN-F or IEC:60245 IEC 66 / CENELEC: H07RN-F)
- Since it has the external power supply, refer to the outdoor unit installation manual for MAIN POWER.

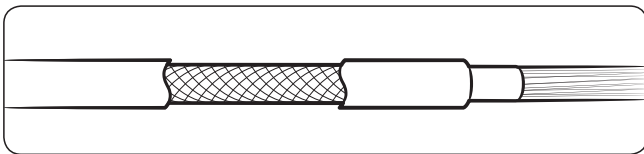

⚠ CAUTION

- When installing the indoor unit in a computer room or a server room, use the double shielded communication cable (tape aluminum / polyester braid + copper) of FROHH2R type.

5. Wall mounted Type

Overview of installation location requirements

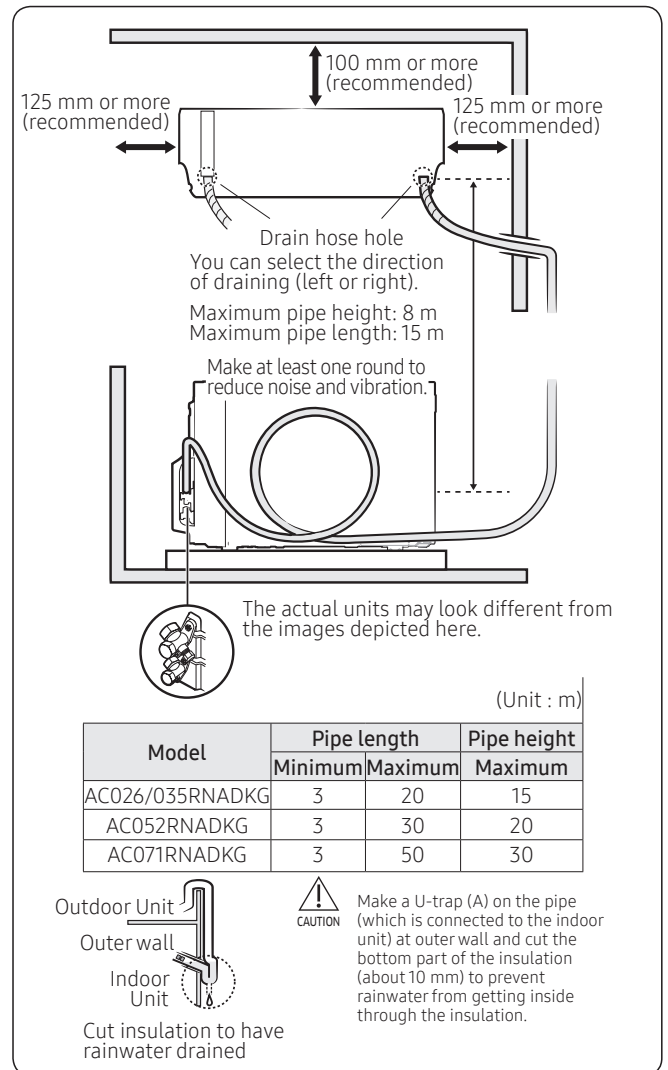

⚠ CAUTION

- Comply with the length and height limits described in the figure above.
- For the product that uses the R-32 refrigerant, Install the indoor unit on the wall 1.8 m or higher from the floor.

※ In case you want more information about the controllers and accessories, please refer to the Controller and Accessory TDB on pvi.Samsung.com site or Global Partner Portal site.

Installation

Drilling a hole through the wall

Before fixing the installation plate to a wall and then fixing the indoor unit to the installation plate, a window frame, or a gypsum board, you must determine the position of a hole (with 65 mm inner diameter) through which the pipe bundle (consisting of power and communication cables, refrigerant pipes, and drain hose) will pass and then drill that hole.

- 1 Determine the position of a 65 mm hole in consideration of the possible directions of the pipe bundle and the minimum distances between the hole and the installation plate.

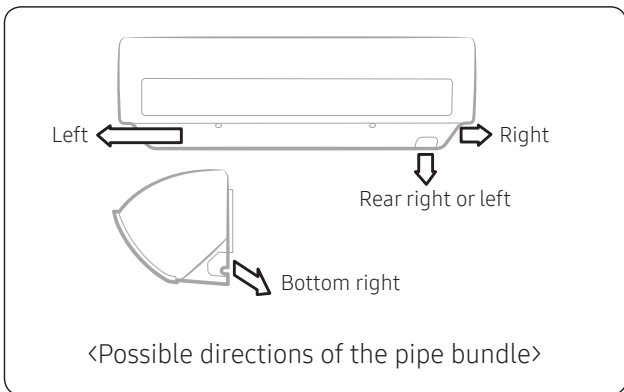

CAUTION

- If changing the pipe direction from left to right, do not drastically bent it but slowly turn it in the opposite direction as shown. Otherwise, the pipe may be damaged in the process.

<Minimum distances between the hole and the installation plate>

(Unit : mm)

Model	A	B	C	D
AC026RNADKG AC035RNADKG	36	60	65	36
AC052RNADKG	36	190	81	36
AC071RNADKG	33	110	110	33

Pipe bundle hole: Ø 65 mm

- 2 Drill the hole.

CAUTION

- Be sure to drill only one hole.
- Make sure that the hole slants downwards so that the drain hose slants downwards to drain water well.

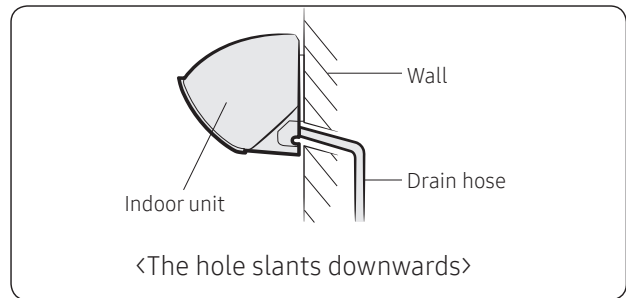

Connecting the power and communication cables (assembly cable)

	Correct	Upside down	Damaged	Non-circular
Before connecting				
After connecting	Correct (Front view)	Correct (Side view)	Upside down	Non-fitted

<Circular terminal>

※ In case you want more information about the controllers and accessories, please refer to the Controller and Accessory TDB on pvi.Samsung.com site or Global Partner Portal site.

Installation

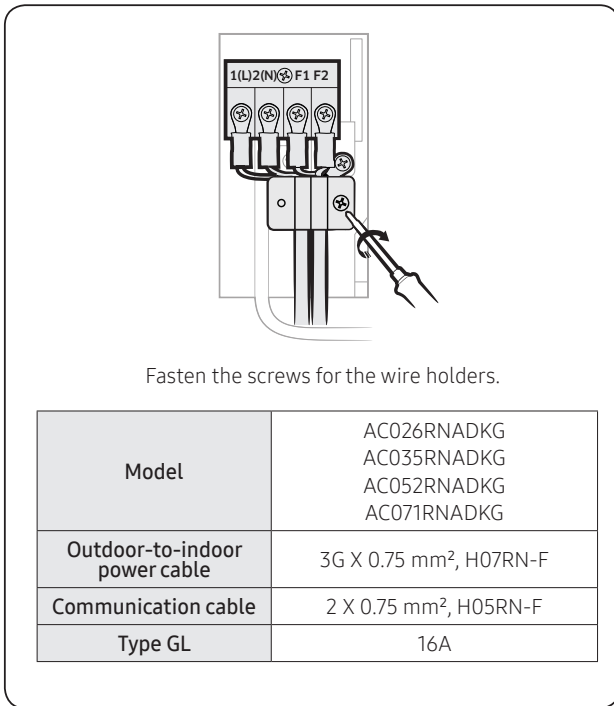

- When performing electrical and earthing works, be sure to comply with the 'technical standards of electrical installations' and the 'wiring regulations' in the local regulations.
- Tighten the terminal block screw to 1.2-1.8 N•m (12-18 kgf•cm).

NOTE

- Each wire is labelled with the corresponding terminal number.
- Use shield cable (Category 5; less than 50pF/m) for noisy environmental site.
- Power supply cords of parts of appliances for outdoor use shall not be lighter than polychloroprene sheathed flexible cord. (Code designation IEC: 60245 IEC 66/CENELEC: H07RN-F, IEC: 60245 IEC 57/CENELEC: H05RN-F)

CAUTION

- For the terminal block wiring, use a wire with a ring terminal socket only. Regular wires without a ring terminal socket may become a hazard due to overheating of the electrical contact during installation.
- Do not connect two or more different cables to extend the length. This connection may cause fire.
- Each circular terminal must match the size of its corresponding screw in the terminal block.
- After connecting the cables, make sure that terminal numbers on the indoor and outdoor units match.
- Ensure that power and communication cables are separated, they must not be in the same cable.
- For the product that uses the R-32 refrigerant, be cautious not to generate a spark by keeping the following requirements:
 - Do not remove the fuses with power on.
 - Do not disconnect the power plug from the wall outlet with power on.
 - It is recommended to locate the outlet in a high position. Place the cords so that they are not tangled.

WARNING

- Connect the wires firmly so that wires cannot be pulled out easily. (If they are loose, it could cause burn-out of the wires.)

Installing and connecting the drain hose

- 1 Install the drain hose.

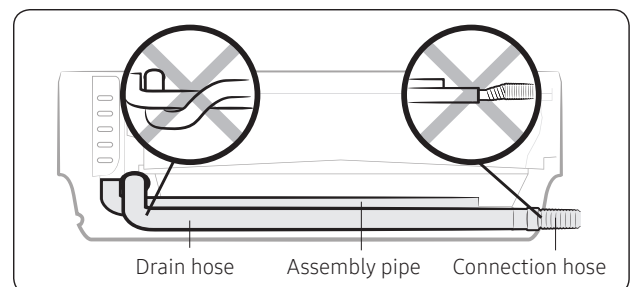

※ In case you want more information about the controllers and accessories, please refer to the Controller and Accessory TDB on pvi.Samsung.com site or Global Partner Portal site.

Installation

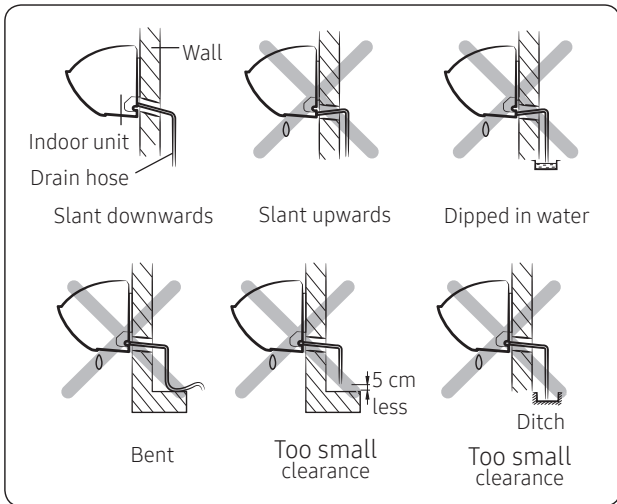

2 Pour water into the drain pan. Check whether the hose is well drained.

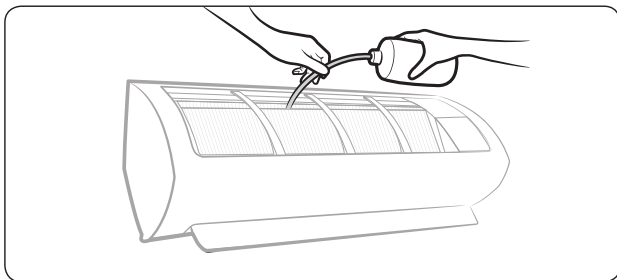

⚠ CAUTION

- Make sure that the indoor unit is in upright position when you pour water to check for leakage. Make sure that the water does not overflow onto the electrical part.
- If the diameter of the connection hose is smaller than the product's drain hose, water leakage may occur.
- Inadequate installation may cause water leakage.
- If the drain hose is routed inside the room, insulate the hose so that dripping condensation does not damage the furniture or floors.
- Do not box in or cover the drain hose connection. Drain hose connection must be easily accessible and serviceable.

6. Ceiling

Installing the indoor unit

Ceiling installation

1 Select pipe directions.

When the directions are selected, drill 3-1/8" (100mm, for pipe and cables) and 1-3/4" (40mm, for drain hose) diameter holes on the wall so that it slants slightly downwards toward the outdoor for smooth water flow.

NOTE

- Use the pattern sheet to select pipe directions.
- 2 Drill holes for anchor bolts according to the distance and mount them.

NOTE

- Use the pattern sheet.

3 Install the unit onto the ceiling. Be sure to arrange the drain hose so that it is leveled lower than the drain hose connecting port of the indoor unit.

NOTE

- For proper drainage of condensate, give a 2° (The gap between the lower end of the indoor unit and the ceiling should be 23~ mm or more.) slant to the side of the unit which will be connected with the drain hose as shown in the figure.

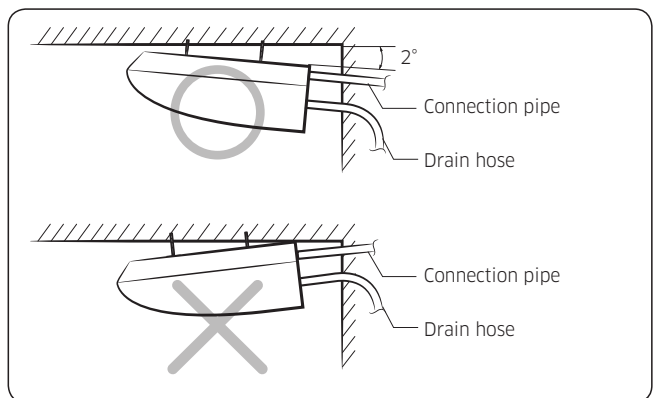

※ In case you want more information about the controllers and accessories, please refer to the Controller and Accessory TDB on pvi.Samsung.com site or Global Partner Portal site.

Installation

⚠ CAUTION

- Ensure that the ceiling is strong enough to support the weight of the indoor unit.
- Before hanging the unit, test the strength of each attached suspension bolt.
- Install the drain hose from the rear of the unit.

📄 NOTE

- The gap between the lower end of the indoor unit and the ceiling should be 1° or 16 mm.

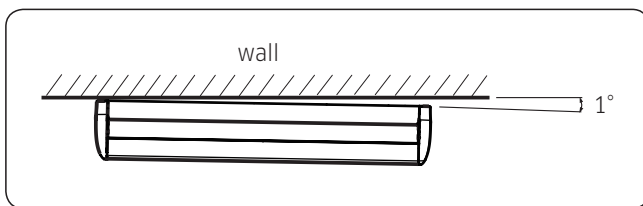

- 4 If installing on dropped ceiling, install threaded rod onto anchor bolt-(expansion bolt) to long enough to suspend the unit right below the dropped ceiling and the install the unit suspending on the threaded rod.

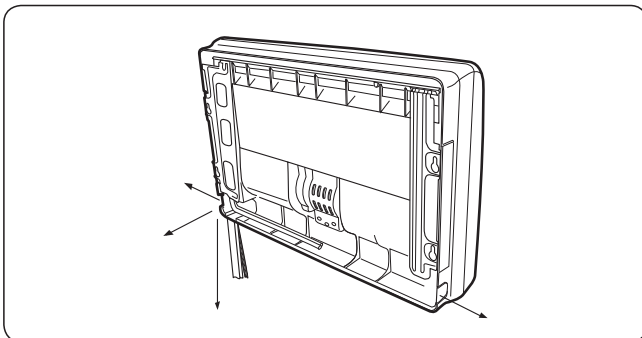

Purging inert gas from the indoor unit

The indoor unit comes with nitrogen gas (inert gas) charged at the factory. Therefore, all inert gas must be purged before connecting the assembly piping.

Unscrew the pinch pipe at the end of each refrigerant pipe.

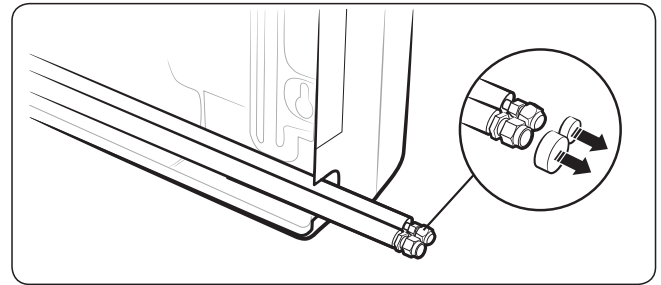

📄 NOTE

- To prevent dirt or foreign objects from getting into the pipes during installation, do not remove the pinch pipe completely until you are ready to connect the piping.

Installing the drain hose and drain pipe

Care must be taken when installing the drain hose for the indoor unit to ensure that any condensation water is correctly drained outside.

📄 NOTE

- Installing the drain hose should be the shorter, the better.
- In order to discharge condensate water, a downward gradient should be maintained.
- Fix the drain hose with Cable-Tie, so that it will not separate from the machine.

- 1 Insert the drain hose to bottom of the outfall of water basin.
- 2 Lock flexible hose clamp of the drain hose according to the figure.
- 3 Wind and wrap flexible hose clamp and drain hose fully with thermal insulation sponge; fix both ends of external layer with ribbon for thermal insulation.

※ In case you want more information about the controllers and accessories, please refer to the Controller and Accessory TDB on pvi.Samsung.com site or Global Partner Portal site.

Installation

4 After being installed, drain hose must be insulated fully by heat insulating material. (To be provided at site.)

- Be sure to tighten the flexible hose clamp of the drain hose.
- Wrap the insulation after attaching the flexible hose clamp.

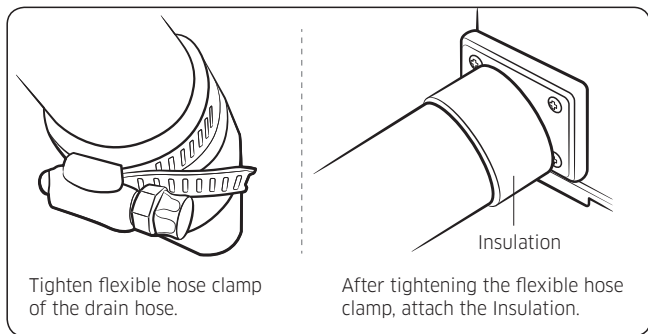
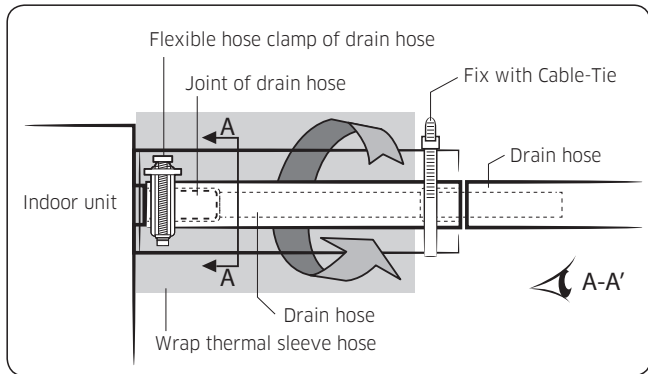

When passing the drain hose through the hole drilled in the wall, check that none of the following situations occur:

Ceiling installation

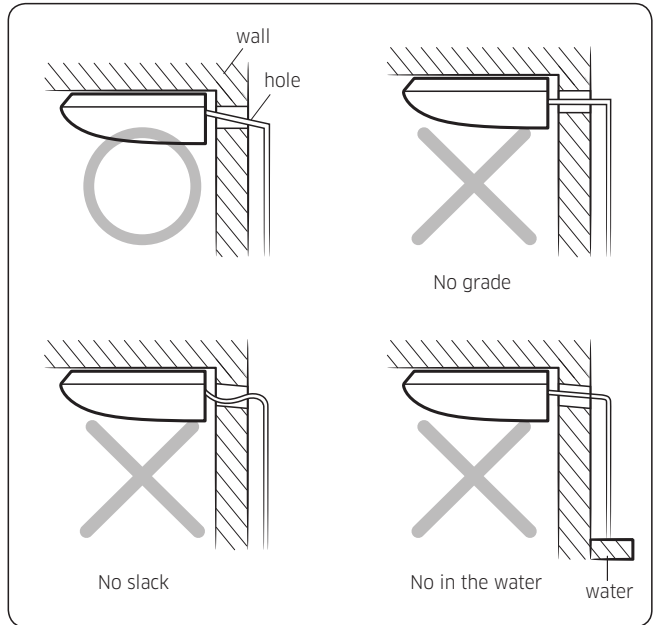

Optional: Extending the power cable

1 Prepare the following tools.

Tools	Spec	Shape
Crimping pliers	MH-14	
Connection sleeve (mm)	20xØ6.5 (HxOD)	
Insulation tape	Width 19 mm	
Contraction tube (mm)	70xØ8.0 (LxOD)	

2 As shown in the figure, peel off the shields from the rubber and wire of the power cable.

- Peel off 20 mm of cable shields from the pre-installed tube.

⚠ CAUTION

- For information about the power cable specifications for indoor and outdoor units, refer to the installation manual.
- After peeling off cable wires from the pre-installed tube, insert a contraction tube.

※ In case you want more information about the controllers and accessories, please refer to the Controller and Accessory TDB on pvi.Samsung.com site or Global Partner Portal site.

Installation

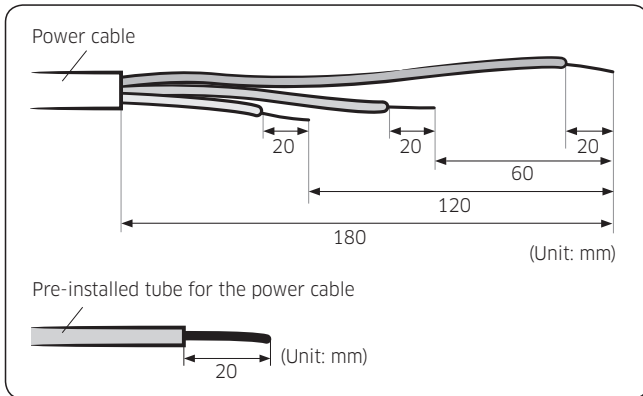

3 Insert both sides of core wire of the power cable into the connection sleeve.

- **Method 1:** Push the core wire into the sleeve from both sides.
- **Method 2:** Twist the wire cores together and push it into the sleeve.

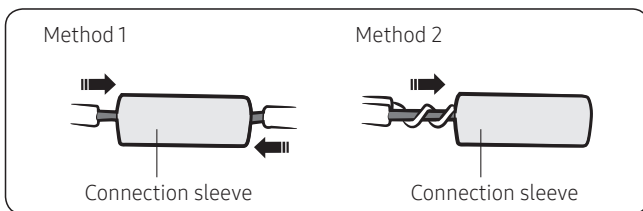

4 Using a crimping tool, compress the two points and flip it over and compress another two points in the same location.

- The compression dimension should be 8.0.

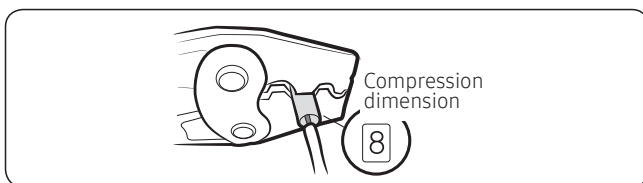

- After compressing it, pull both sides of the wire to make sure it is firmly pressed.

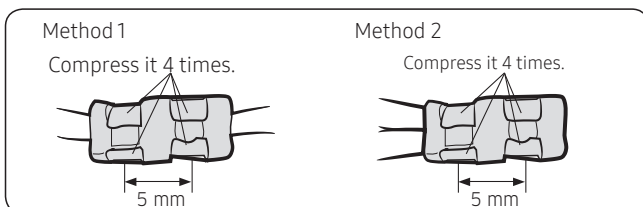

5 Wrap it with the insulation tape twice or more and position your contraction tube in the middle of the insulation tape. Three or more layers of insulation are required.

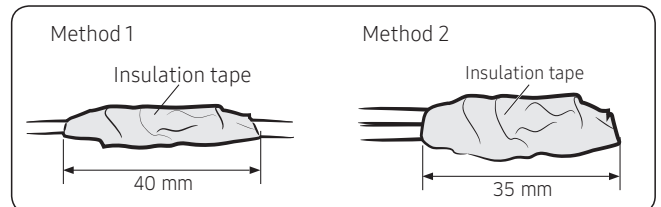

6 Apply heat to the contraction tube to contract it.

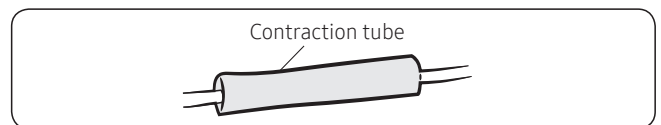

7 After tube contraction work is completed, wrap it with the insulation tape to finish.

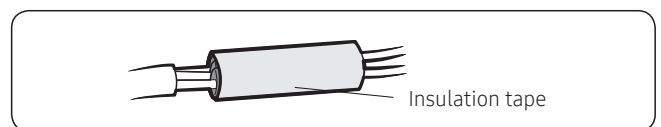

CAUTION

- Make sure that the connection parts are not exposed to outside.
- Be sure to use insulation tape and a contraction tube made of approved reinforced insulating materials that have the same level of withstand voltage with the power cable. (Comply with the local regulations on extensions.)

WARNING

- In case of extending the electric wire, please DO NOT use a round-shaped Pressing socket.
 - Incomplete wire connections can cause electric shock or a fire.

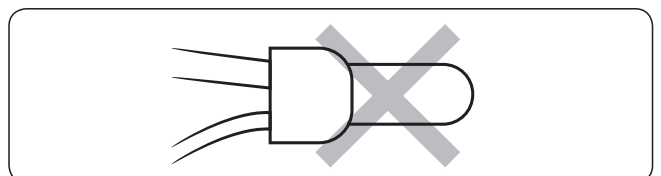

※ In case you want more information about the controllers and accessories, please refer to the Controller and Accessory TDB on pvi.Samsung.com site or Global Partner Portal site.

Installation

7. Outdoor Unit

Installation location requirements

- The outdoor unit shall be installed in an open space that is always ventilated.
- The local gas regulations shall be observed.
- For installation inside a building (this applies either to indoor or outdoor units installed inside) a minimum room floor area of space conditioned is mandatory according to EN378-1:2017 (see the reference table into the indoor unit installation manual).
- To handle, purge, and dispose the refrigerant, or break into the refrigerant circuit, the worker should have a certificate from an industry-accredited authority.
- Do not install the air conditioner in following areas.
 - The place where there is mineral oil or arsenic acid. Resin parts flame and the accessories may drop or water may leak. The capacity of the heat exchanger may reduce or the air conditioner may be out of order.
 - The place where corrosive gas such as sulfurous acid gas generates from the vent pipe or air outlet. The copper pipe or connection pipe may corrode and refrigerant may leak.
 - The place where there is a machine that generates electromagnetic waves. The air conditioner may not operate normally due to control system.
 - The place where there is a danger of existing combustible gas, carbon fiber or flammable dust.
 - The place where animals may urinate on the product. Ammonia may be generated.
 - The place where thinner or gasoline is handled. Gas may leak and it may cause fire.
 - The place where is close to heat sources
- Do not use the indoor unit for preservation of food items, plants, equipment, and art works. This may cause deterioration of their quality.
- Do not install the indoor unit if it has any drainage problem.
- Do not place the outdoor unit on its side or upside down. Failing to do so may cause the compressor lubrication oil to run into the cooling circuit and lead to a serious damage to the unit.

- Install the unit in a well-ventilated location away from direct sunlight or strong winds.
- Install the unit in a location that would not obstruct any passageways or thoroughfares.
- Install the unit in a location that would not inconvenience or disturb your neighbors, as they could be affected by the noise or the airflow coming from the unit.
- Install the unit in a location where the pipes and the cables can be easily connected to the indoor unit.
- Install the unit on a flat, stable surface that can withstand the weight of the unit. Otherwise, the unit can generate noise and vibration during operation.
- Install the unit so that the air flow is directed towards the open area.
- Maintain sufficient clearance around the outdoor unit, especially from a radio, computer, stereo system, etc.

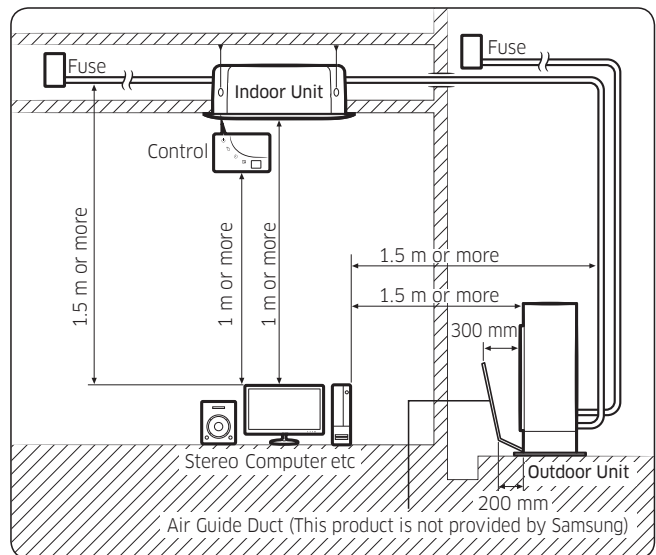

- Install the unit at a height where its base can be firmly fixed in place.
- Make sure that the water dripping from the drain hose runs away correctly and safely.

⚠ CAUTION

- You have just purchased a system air conditioner and it has been installed by your installation specialist.
- This device must be installed according to the national electrical rules.
- If your outdoor unit exceeds a net weight of 60 kg, do not install it on a suspended wall, but stand it on a floor.

※ In case you want more information about the controllers and accessories, please refer to the Controller and Accessory TDB on pvi.Samsung.com site or Global Partner Portal site.

Installation

- When installing the outdoor unit at the seaside, make sure that it is not directly exposed to sea breeze. If you cannot find an adequate place free from direct sea breeze, construct a protection wall or a protective fence.
 - Install the outdoor unit in a place (such as near buildings etc.) where it can be prevented from sea breeze. Failure to do so may cause a damage to the outdoor unit.

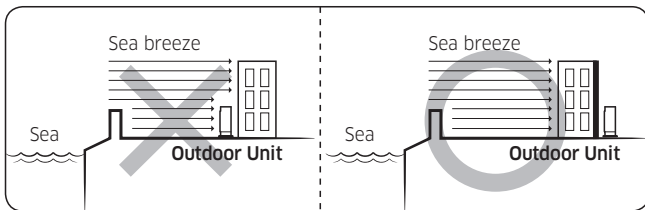

- If you cannot avoid installing the outdoor unit at the seaside, construct a protection wall around to block the sea breeze.
- Construct a protection wall with a solid material such as concrete to block the sea breeze. Make sure that the height and the width of the wall are 1.5 times larger than the size of the outdoor unit. Also, secure a space larger than 700 mm between the protection wall and the outdoor unit for exhausted air to ventilate.

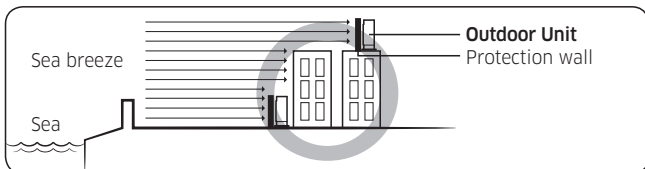

⚠ CAUTION

- Depending on the condition of power supply, unstable power or voltage may cause malfunction of the parts or control system. (At the ship or places using power supply from electric generator...etc)
- Install the unit in a place where water can drain smoothly.
- If you have any difficulty finding installation location as prescribed above, contact your manufacturer for details.
- Be sure to clean the sea water and the dust on the heat exchanger of the outdoor unit and apply a corrosion inhibitor on it. (At least once in a year.)

- Check the condition of the product periodically.
 - Check the installation site every 3 months and perform anti-corrosion treatment such as R-Pro supplied by SAMSUNG (Code : MOK-220SA) or commercial water repellent grease and wax, etc., based on the product condition.
 - When the product is to be shut down for a long period of time, such as off-peak hours, take appropriate measures like covering the product.
- If the product installed within 500m of seashore, special anti-corrosion treatment is required.
 - ※ Please contact your local SAMSUNG representative for further details.

Outdoor unit dimensions

(Unit: mm)

A Type	
AC026RXADKG/AC035RXADKG	
B Type	
AC052RXADKG	
C Type	
AC071RXADKG	

※ In case you want more information about the controllers and accessories, please refer to the Controller and Accessory TDB on pvi.Samsung.com site or Global Partner Portal site.

Installation

Minimum clearances for the outdoor unit

When installing 1 outdoor unit

(Unit: mm)

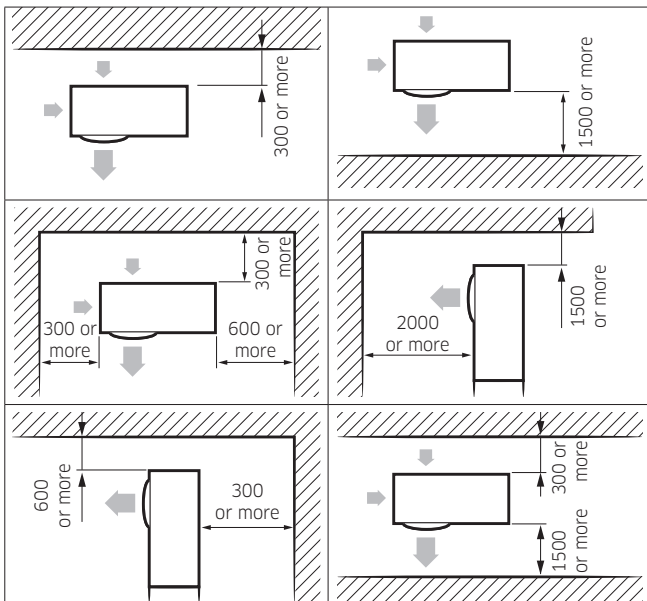

When installing more than 1 outdoor unit

(Unit: mm)

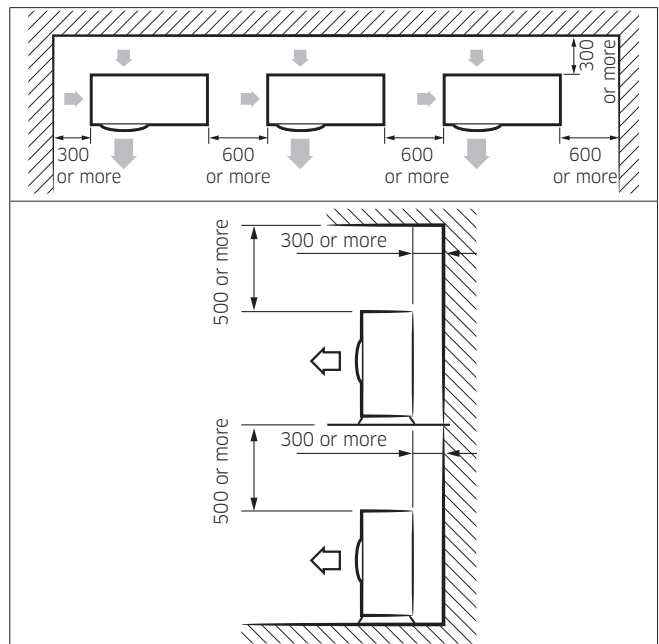
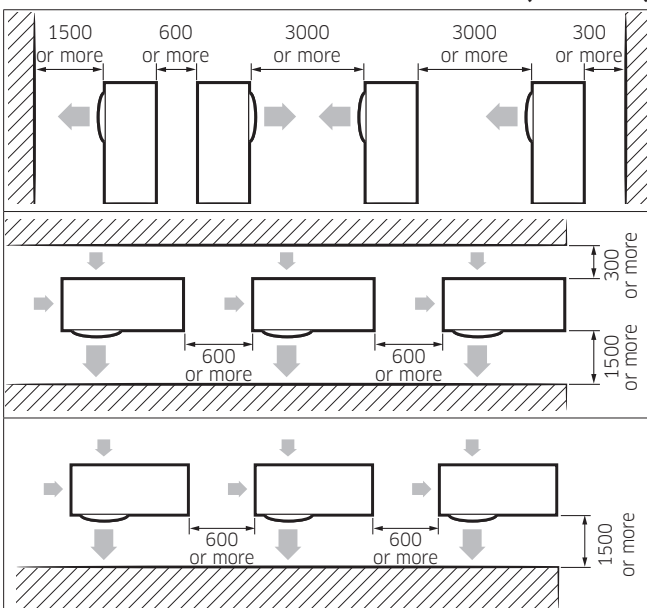

⚠ CAUTION

- The outdoor unit must be installed according to the specified distances in order to permit accessibility from each side, to guarantee correct operation, maintenance, and repair of the unit. The components of the outdoor unit must be reachable and removable under safe conditions for people and the unit.

⚠ WARNING

- Should adopt bar type louver. Don't use a type of rain resistance louver.

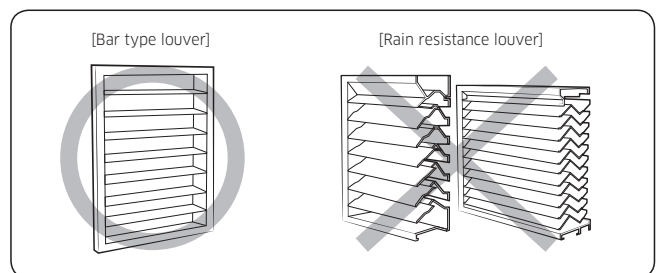

- Louver specifications.
 - Angle criteria : less than 20°
 - Opening ratio criteria : greater than 80%

※ In case you want more information about the controllers and accessories, please refer to the Controller and Accessory TDB on pvi.Samsung.com site or Global Partner Portal site.

Installation

Moving the outdoor unit with wire rope

- 1 Before carrying the outdoor unit, fasten two wire ropes of 8 m or longer, as shown in the figure.
- 2 To prevent damages or scratches effectively, insert a piece of cloth between the outdoor unit and the ropes.
- 3 Move the outdoor unit.

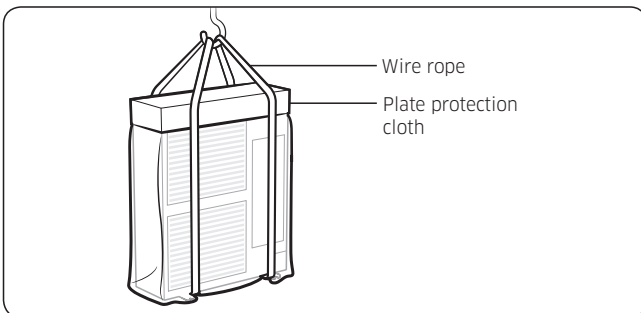

Fixing the outdoor unit in place

Install the outdoor unit on a rigid and stable base to prevent disturbance from any noise caused by vibration. When installing the unit at a height or in a location exposed to strong winds, fix the unit securely to a support (i.e., a wall or a ground).

Fix the outdoor unit with anchor bolts. Make sure that the anchor bolts are 20 mm or higher from the base surface.

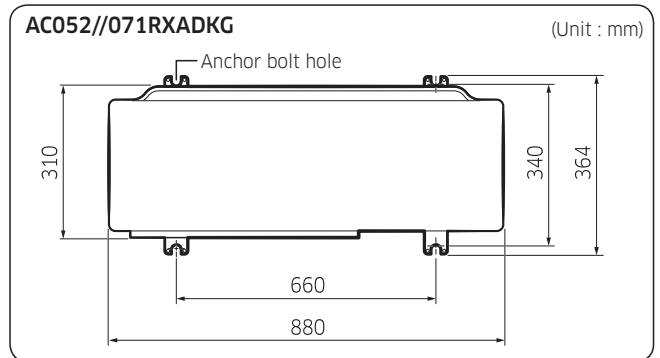
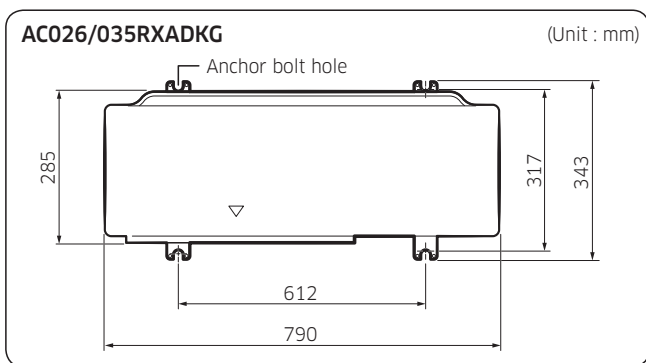

CAUTION

- Install a drain outlet at the lowest end around the base for outdoor unit drainage
- When installing the outdoor unit on the roof, waterproof the unit and check the ceiling strength.

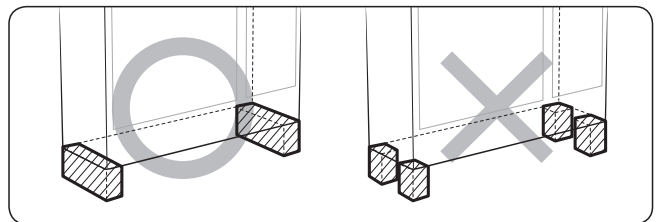

- Make sure that the wall can support the weights of the rack and the outdoor unit.
- Install the rack close to the column as much as possible.

※ In case you want more information about the controllers and accessories, please refer to the Controller and Accessory TDB on pvi.Samsung.com site or Global Partner Portal site.

Installation

Optional: Fixing the outdoor unit to a wall with a rack

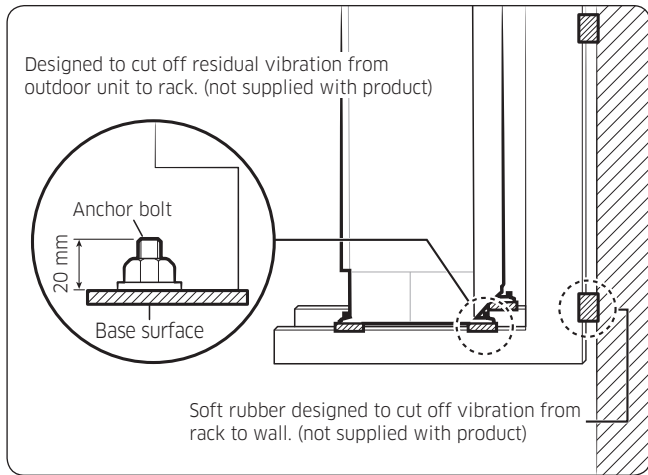

- Install a proper grommet in order to reduce noise and residual vibration transferred by the outdoor unit towards the wall.

CAUTION

- When installing an air guide duct, be sure to check the following:
 - The screws do not damage the copper pipe.
 - The air guide duct is fixed firmly on the guard fan.

Connecting the power cables, communication cable, and controllers

You must connect the following three electrical cables to the outdoor unit:

- The main power cable between the auxiliary circuit breaker and the outdoor unit.
- The outdoor-to-indoor power cable between the outdoor unit and the indoor unit.
- The communication cable between the outdoor unit and the indoor unit.

CAUTION

- During installation, make first the refrigerant connections and then the electrical connections. If the unit is uninstalled, first disconnect the electrical cables and then the refrigerant connections.
- Connect the air conditioner to the earthing system before making the electrical connections.

NOTE

- Especially, if your outdoor unit is the one designed for Russian and European markets, consult the supply authority, if necessary, to estimate and reduce the supply system impedance before installation.

Air conditioning system examples

When using earth leakage circuit breaker (ELCB) for a single phase

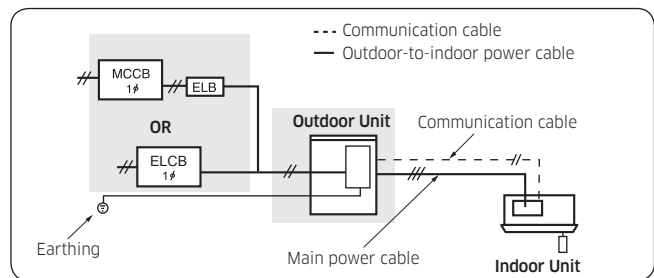

CAUTION

- If the outdoor unit is installed in a location vulnerable to an electric leak or submergence, make sure to install an ELCB.
- For the product that uses the R-32 refrigerant, be cautious not to generate a spark by keeping the following requirements:
 - Do not remove the fuses with power on.
 - Do not disconnect the power plug from the wall outlet with power on.
 - It is recommended to locate the outlet in a high position. Place the cords so that they are not tangled.

※ In case you want more information about the controllers and accessories, please refer to the Controller and Accessory TDB on pvi.Samsung.com site or Global Partner Portal site.

Installation

Connecting the main power cable

When using ELB for 1 phase

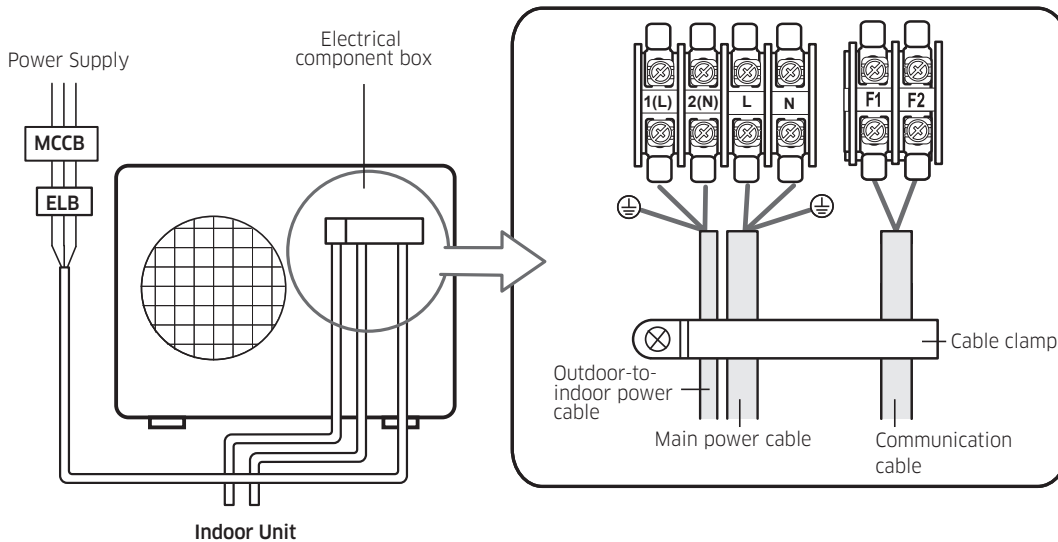

The appearance of the unit may be different from the picture depending on the model.

⚠ CAUTION

- You should connect the power cable into the power cable terminal and fasten it with a clamp.
- The unbalanced power must be maintained within 2% of supply rating. If the power is unbalanced greatly, it may shorten the life of the condenser. If the unbalanced power is exceeded over 4% of supply rating, the indoor unit is protected, stopped and the error mode indicates.
- To protect the product from water and possible shock, you should keep the power cable and the connection cord of the indoor and outdoor units within ducts. (with appropriate IP rating and material selection for your application)
- Ensure that main supply connection is made through a switch that disconnects all poles, with contact gap of a least 3 mm.
- Devices disconnected from the power supply should be completely disconnected in the condition of overvoltage category.
- Keep distances of 50 mm or more between power cable and communication cable.

Main power terminal block specifications

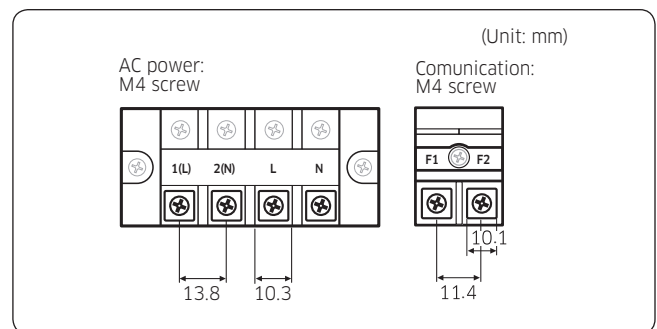

Main power cable specifications

The power cable is not supplied with air conditioner.

- Select the power supply cable in accordance with relevant local and national regulations.
- Wire size must comply with the applicable local and national code.
- Specifications for local wiring power cord and branch wiring are in compliance with local cord.

※ In case you want more information about the controllers and accessories, please refer to the Controller and Accessory TDB on pvi.Samsung.com site or Global Partner Portal site.

Installation

Type	Model		Outdoor unit				Input current (Amperes)				Power supply	
	Indoor unit	Outdoor unit	Rated	Voltage range		Outdoor unit		Indoor unit	Total	MCA	MFA	
			Hz	Volts	Min.	Max.	Cooling					Heating
A	AC026RN1DKG	AC026RXADKG	50	220 to 240	198	264	10.0	10.0	1.0	11.0	11.0	12.5
	AC026RNNDKG	AC026RXADKG	50	220 to 240	198	264	10.0	10.0	1.0	11.0	11.0	12.5
	AC026RNLDKG	AC026RXADKG	50	220 to 240	198	264	10.0	10.0	1.7	11.7	11.7	12.9
	AC026RNADKG	AC026RXADKG	50	220 to 240	198	264	10.0	10.0	1.6	11.6	11.6	12.8
	AC035RN1DKG	AC035RXADKG	50	220 to 240	198	264	10.0	10.0	1.0	11.0	11.0	12.5
	AC035RNNDKG	AC035RXADKG	50	220 to 240	198	264	10.0	10.0	1.0	11.0	11.0	12.5
	AC035RNMDKG	AC035RXADKG	50	220 to 240	198	264	10.0	10.0	2.5	12.5	12.5	13.8
	AC035RNLDKG	AC035RXADKG	50	220 to 240	198	264	10.0	10.0	1.7	11.7	11.7	12.9
	AC035RNADKG	AC035RXADKG	50	220 to 240	198	264	10.0	10.0	1.6	11.6	11.6	12.8
B	AC052RN4DKG	AC052RXADKG	50	220 to 240	198	264	16.5	16.5	1.0	17.5	17.5	20.6
	AC052RNNDKG	AC052RXADKG	50	220 to 240	198	264	16.5	16.5	1.0	17.5	17.5	20.6
	AC052RNMDKG	AC052RXADKG	50	220 to 240	198	264	16.5	16.5	2.5	19.0	19.0	20.9
	AC052RNLDKG	AC052RXADKG	50	220 to 240	198	264	16.5	16.5	1.7	18.2	18.2	20.6
	AC052RNCDKG	AC052RXADKG	50	220 to 240	198	264	16.5	16.5	1.0	17.5	17.5	20.6
	AC052RNADKG	AC052RXADKG	50	220 to 240	198	264	16.5	16.5	1.6	18.1	18.1	20.6
C	AC071RN4DKG	AC071RXADKG	50	220 to 240	198	264	16.5	16.5	1.0	17.5	17.5	20.6
	AC071RNNDKG	AC071RXADKG	50	220 to 240	198	264	16.5	16.5	1.0	17.5	17.5	20.6
	AC071RN4PKG	AC071RXADKG	50	220 to 240	198	264	16.5	16.5	1.5	18.0	18.0	20.6
	AC071RNMDKG	AC071RXADKG	50	220 to 240	198	264	16.5	16.5	2.5	19.0	19.0	20.9
	AC071RNLDKG	AC071RXADKG	50	220 to 240	198	264	16.5	16.5	1.7	18.2	18.2	20.6
	AC071RNCDKG	AC071RXADKG	50	220 to 240	198	264	16.5	16.5	1.0	17.5	17.5	20.6
	AC071RNADKG	AC071RXADKG	50	220 to 240	198	264	16.5	16.5	1.6	18.1	18.1	20.6

NOTE

- 1 Voltage range
 - Units are suitable for use on electrical systems where voltage supplied to unit terminal is not below or above listed range limits
- 2 Maximum allowable voltage variation between phases is 2%.
- 3 Wire size & type must comply with the applicable local and national code.
 - Wire size: Based on the value of MCA.
 - Wire type: 60245 IEC57(IEC) or H05RN-F(CENELEC) grade or more.
- 4 MFA is used to select the circuit breaker and the ground fault circuit interrupter (earth leakage circuit breaker).
- 5 MCA represents maximum input current.
 - MFA represents capacity which may accept MCA
 - Abbreviations
MCA: Min. Circuit Amps. (A)
MFA: Max. Fuse Amps. (A)

※ In case you want more information about the controllers and accessories, please refer to the Controller and Accessory TDB on pvi.Samsung.com site or Global Partner Portal site.

Installation

Connecting the outdoor-to-indoor power cable and the communication cable

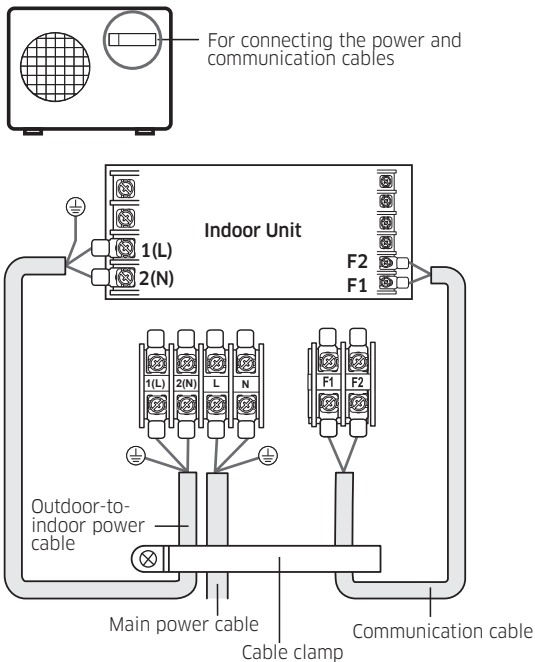

NOTE

- Lay the electrical wiring so that the front cover does not rise up when doing wiring work and attach the front cover securely.
- Ground wire for the indoor unit and outdoor unit connection cable must be clamped to a soft copper tin-plated eyelet terminal with M4 screw hole (NOT SUPPLIED WITH UNIT ACCESSORIES).

Outdoor-to-indoor power terminal specifications

- Connect the cables to the terminal board using the compressed ring terminal.
- Cover a solderless ring terminal and a connector part of the power cable and then connect it.

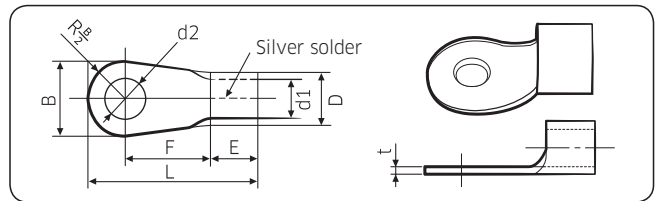

Nominal dimensions for cable (mm ²)	Nominal dimensions for screw (mm)	B		D		d1		E (mm)	F (mm)	L (mm)	d2		t (mm)
		Standard dimension (mm)	Allowance (mm)	Standard dimension (mm)	Allowance (mm)	Standard dimension (mm)	Allowance (mm)				Standard dimension (mm)	Allowance (mm)	
4/6	4	9.5	±0.2	5.6	+0.3 -0.2	3.4	±0.2	6	5	20	4.3	+0.2 0	0.9
	8	15							9		28.5	+0.4 0	
10	8	15	±0.2	7.1	+0.3 -0.2	4.5	±0.2	7.9	9	30	8.4	+0.4 0	1.15
16	8	16	±0.2	9	+0.3 -0.2	5.8	±0.2	9.5	13	33	8.4	+0.4 0	1.45
25	8	12	±0.3	11.5	+0.5 -0.2	7.7	±0.2	11	15	34	8.4	+0.4 0	1.7
	8	16.5							13		8.4		
35	8	16	±0.3	13.3	+0.5 -0.2	9.4	±0.2	12.5	13	38	8.4	+0.4 0	1.8
	8	22							13		43	8.4	
50	8	22	±0.3	13.5	+0.5 -0.2	11.4	±0.3	17.5	14	50	8.4	+0.4 0	1.8
70	8	24	±0.4	17.5	+0.5 -0.4	13.3	±0.4	18.5	20	51	8.4	+0.4 0	2.0

- Connect the rated cables only.
- Connect using a driver which is able to apply the rated torque to the screws.
- If the terminal is loose, fire may occur caused by arc. If the terminal is connected too firmly, the terminal may be damaged.

※ In case you want more information about the controllers and accessories, please refer to the Controller and Accessory TDB on pvi.Samsung.com site or Global Partner Portal site.

Installation

Tightening torque (kgf • cm)	
M4	12.0 to 18.0
M5	20.0 to 30.0

- 1N · m = 10 kgf · cm

⚠ CAUTION

- When connecting cables, you can connect the cables to the electrical part or connect them through the holes below depending on the spot.
- Connect the communication cable between the indoor and outdoor units through a conduit to protect against external forces, and feed the conduit through the wall together with refrigerant piping.
- Remove all burrs at the edge of the knock-out hole and secure the cable to the outdoor knock-out using lining and bushing with an electrical insulation such as rubber and so on.
- Must keep the cable in a protection tube.
- Keep distances of 50mm or more between power cable and communication cable.
- When the cables are connected through the hole, remove the Plate bottom.

Outdoor-to-indoor power and communication cables specifications

Indoor power supply		
Power supply	Max/Min (V)	Indoor power cable
1Φ, 220-240V, 50 Hz	±10%	1.5 mm ² ↑, 3 wires
Communication cable		
0.75 to 1.5 mm ² , 2 wires		

- Power supply cords of parts of appliances for outdoor use shall not be lighter than polychloroprene sheathed flexible cord. (Code designation IEC:60245 IEC 57 / CENELEC: H05RN-F or IEC:60245 IEC 66 / CENELEC: H07RN-F)
- When installing the indoor unit in a computer room or net work room, use the double shielded (tape aluminium / polyester braid + copper) cable of FROHH2R type.

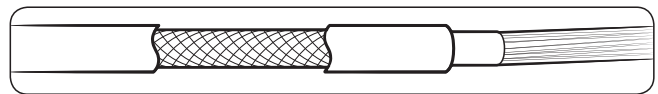

Connecting the refrigerant pipe

Items	Maximum allowable length			
	Single installation			DPM installation
Applicable outdoor unit models	AC026RXADKG AC035RXADKG	AC052RXADKG	AC071RXADKG	AC071RXADKG
Total pipe length (L ₁ +L ₂ +L ₃)	-	-	-	50m
Main pipe (L ₁)	20m	30m	50m	30m
Max. distance among indoor units (D)	-	-	-	10m
Max. length after branch	-	-	-	15m
Max. height difference between outdoor and indoor units (h ₁)	15m	20m	30m	±30m
Max. height difference among indoor units(h ₂)	-	-	-	±0.5m
Max Pipe length difference among indoor units after branch (L ₂ -L ₃)	-	-	-	±5m

※ In case you want more information about the controllers and accessories, please refer to the Controller and Accessory TDB on pvi.Samsung.com site or Global Partner Portal site.

Installation

※ “n” means the number of indoor unit connection of DPM.

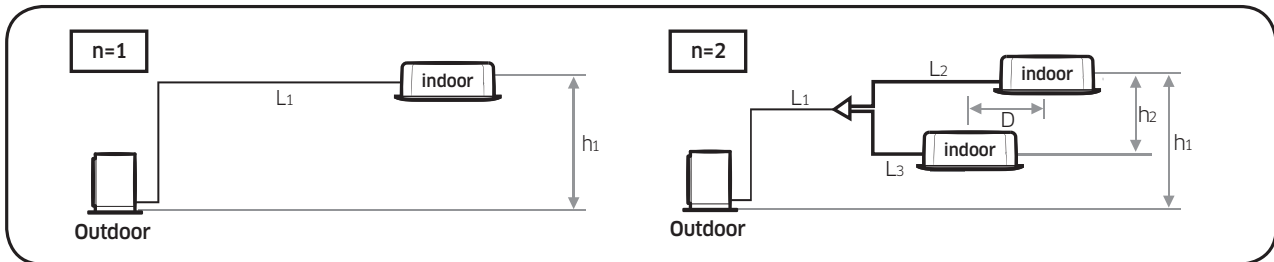

※ Use a joint kit that is only for DPM.

- Temper grade and minimum thickness of the refrigerant pipe

Outer diameter [mm]	Minimum thickness [mm]	Temper grade
ø6.35	0.7	C1220T-O
ø9.52	0.7	
ø12.70	0.8	
ø15.88	1.0	
ø15.88	0.8	C1220T-1/2H OR C1220T-H
ø19.05	0.9	
ø22.23	0.9	

⚠ CAUTION

- Be sure to use C1220T-1/2H (Semi-hard) pipe for more than Ø19.05 mm. If you use C1220T-O (Soft) pipe for Ø19.05 mm, the pipe may be broken, which can result in an injury.

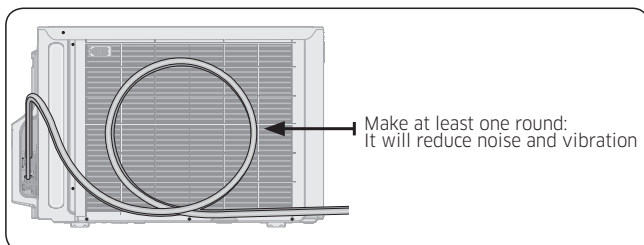

- The appearance of the unit may be different from the diagram depending on the model.

⚠ CAUTION

- After connecting the pipes with knock-out treatment, plug the space around the pipes.
- After connecting the pipes, proceed exactly as directed in the guide to prevent interference with the internal parts.
- Tighten the nuts to the specified torques. If overtightened, the nuts could be broken so refrigerant may leak.
- Protect or enclose refrigerant tubing to avoid mechanical damage.

Adding refrigerant (R-32)

Precautions on adding the R-32 refrigerant

In addition to the conventional charging procedure, the following requirements shall be kept.

- Make sure that contamination by other refrigerants does not occur for charging.
- To minimize the amount of refrigerant, keep the hoses and lines as short as possible.
- The cylinders shall be kept upright.
- Make sure that the refrigeration system is earthed before charging.
- Label the system after charging, if necessary.
- Extreme care is required not to overcharge the system.
- Before recharging, the pressure shall be checked with nitrogen blowing.
- After charging, check for leakage before commissioning.

※ In case you want more information about the controllers and accessories, please refer to the Controller and Accessory TDB on pvi.Samsung.com site or Global Partner Portal site.

Installation

- Be sure to check for leakage before leaving the work area.
 - The outdoor unit is loaded with sufficient refrigerant for the standard piping. Thus, refrigerant must be added if the piping is lengthened. This operation can only be performed by a qualified refrigeration specialist. To determine the quantity of refrigerant charge, see **Calculating the quantity of refrigerant to add** on page 217.
- 1 Check if the stop valve is closed completely.
 - 2 Charge the refrigerant through the service port of the liquid stop valve.
 - 3 If you have any difficulty charging the refrigerant as described in the steps above, take the following steps:
 - a Open the liquid stop valve and gas stop valve.
 - b Operate the air conditioner by pressing the K2 key on the outdoor unit PCB.
 - c After about 30 minutes, charge the refrigerant through the service port of the gas stop valve.

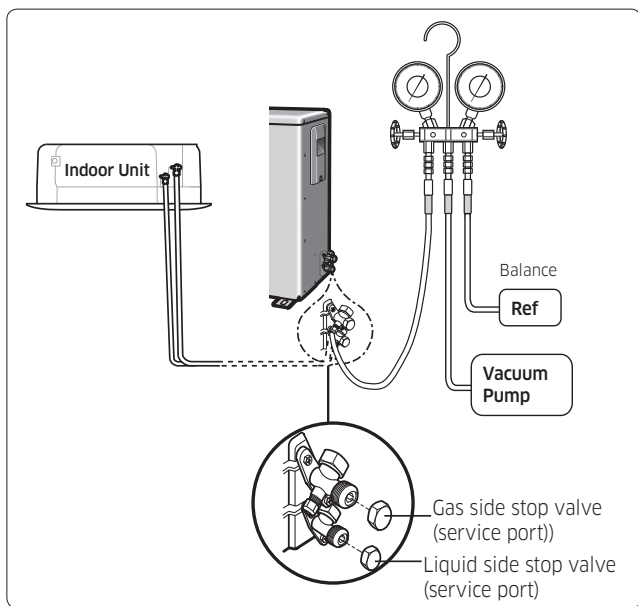

Important information: regulation regarding the refrigerant used

This product contains fluorinated greenhouse gases. Do not vent gases into the atmosphere.

⚠ CAUTION

- Inform user if the system contains 5 tCO₂e or more of fluorinated greenhouse gases. In this case, it must be checked for leakage at least once every 12 months, according to regulation No. 517/2014. This activity must be covered by qualified personnel only. In the case of the situation above, the installer (or authorized person with responsibility for final check) must provide a maintenance book, with all the information recorded, according to REGULATION (EU) No. 517/2014 OF THE EUROPEAN PARLIAMENT AND OF THE COUNCIL of 16 April 2014 on fluorinated greenhouse gases.

Please fill in the following with indelible ink on the refrigerant charge label supplied with this product and on this manual.

- ①: The factory refrigerant charge of the product.
- ②: The additional refrigerant amount charged in the field.
- ① + ②: The total refrigerant charge.

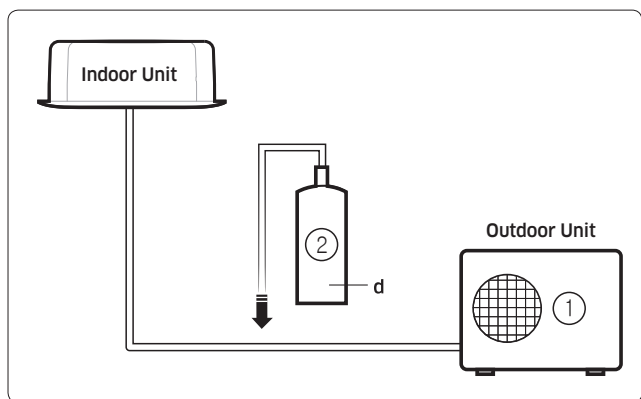

Unit	kg	tCO ₂ e
①, a		
②, b		
① + ②, c		

※ In case you want more information about the controllers and accessories, please refer to the Controller and Accessory TDB on pvi.Samsung.com site or Global Partner Portal site.

Installation

Refrigerant type	GWP value
R-32	675

- GWP: Global Warming Potential
- Calculating tCO₂e : kg x GWP/1000

NOTE

- Factory refrigerant charge of the product: see unit name plate
- Additional refrigerant amount charged in the field(Refer to the above information for the quantity of refrigerant replenishment.)
- Total refrigerant charge
- Refrigerant cylinder and manifold for charging

CAUTION

- The filled-out label must be adhered in the proximity of the product charging port (e.g. onto the inside of the stop valve cover).
- Make sure that the total refrigerant charge does not exceed **(A)**, the maximum refrigerant charge, which is calculated in the following formula: Maximum refrigerant charge **(A)** = factory refrigerant charge **(B)** + maximum additional refrigerant charge due to piping extension **(C)**.

(Unit: g)

Model	A	B	C
AC026RXADKG	900	900	0
AC035RXADKG	900	900	0
AC052RXADKG	1450	1200	250
AC071RXADKG	2600	1700	900

Charging the refrigerant under conditions of liquid by using a liquid pipe

R-32 is a mixed type of refrigerant. It is necessary for recharging under conditions of liquid. When recharging refrigerant from the refrigerant cylinder to the equipment, follow the instructions below.

- Before recharging, check whether the cylinder has a siphon or not. There are two ways to recharge the refrigerant.

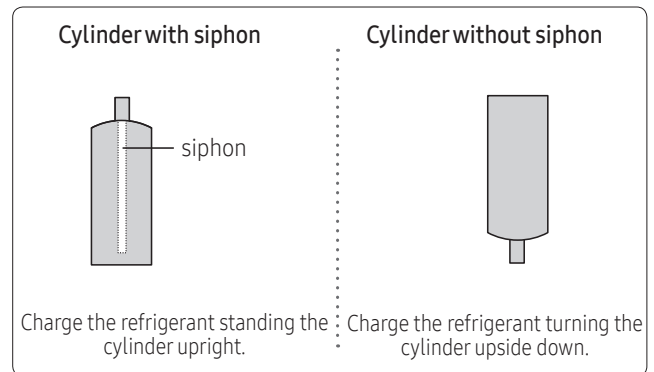

NOTE

- If R-32 refrigerant is charged with gas, the composition of the charged refrigerant changes and the characteristics of the equipment vary.
- During the measuring operation of refrigerant quantity added use an electronic balance.If cylinder doesn't have syphon, upset it.

※ In case you want more information about the controllers and accessories, please refer to the Controller and Accessory TDB on pvi.Samsung.com site or Global Partner Portal site.

Installation

Calculating the quantity of refrigerant to add

The quantity of additional refrigerant is variable according to the installation situation. Thus, make sure the outdoor unit situation before adding refrigerant. This operation can only be performed by a qualified refrigeration specialist.

When installing the outdoor unit only

Model	Interconnection pipe length (m)						
	0 to 5	5 to 10	10 to 15	15 to 20	20 to 30	30 to 40	40 to 50
AC026RXADKG AC035RXADKG	0	0	0	0			
AC052RXADKG	0	0	+ 15 g/m over 10m				
AC071RXADKG			0	+ 25 g/m over 15m			

DPM installation outdoor unit

Model	Diameter of L ₁ , a & b pipe	Installation condition	Amount of additional refrigerant charging
AC071RXADKG	Φ 6.35	L ₁ + L ₂ + L ₃	(L ₁ -5) × 20[g] + (L ₂ +L ₃) × 20[g]

Optional: Installing DPM

DPM allowable Outdoor and indoor unit models

DPM allowable Outdoor and indoor unit models	
Outdoor unit models	2 indoor units connection
	Indoor unit
AC071RXADKG	AC035RN1DKG
	AC035RNNDKG
	AC035RNMDKG
	AC035RNLDKG
	AC035RNADKG

※ Installation of multiple indoor units should consist of units that have the same capacity.

e.g. When you install the AC071RXADKG outdoor unit as DPM combination such as 2 indoor units connection, only the combination on the table is available.

※ In case you want more information about the controllers and accessories, please refer to the Controller and Accessory TDB on pvi.Samsung.com site or Global Partner Portal site.

Installation

Space requirements for indoor and outdoor units and piping installation

(Refer to page 7~10 installation specification.)

- Two indoor units should be installed in one area which is not divided by a wall.
- The distance between two indoor units should be within a straight-line of 10m.
- After branching, the distance between the piping connected to the two indoor units should be within 5m.
- The height difference between two units should be within 0.5m.
- Use the joint KIT that is only for DPM. (Please refer to the table below)

DPM KIT	2-Indoor units connection	3-Indoor units connection	4-Indoor units connection
	MXJ-2D2509K	MXJ-3D2509K	MXJ-4D2509K

Connecting communication line and wired remote controller

In case of 2 indoor units connection

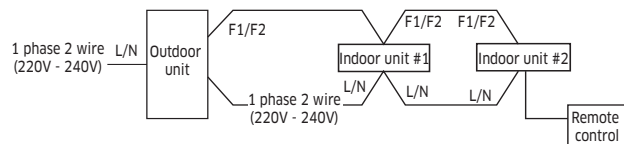

※ The wired remote controller can be used with any of the DPM indoor units.

Operation and specification

- The two, the three, or the four sets of the indoor units with DPM installation which are controlled by wired and wireless remote controller work equally. (All controls such as ON/OFF, cooling/heating/dehumidification/ventilation, high/ medium/low wind.)
- Thermo OFF which stops when indoor temperature reaches set temperature works by the average sensor value of the indoor temperature of the all indoor units.
- When one of the several indoor units has a problem, they protect operation or stop working.

Instruction for installation and operation

- You should install the DPM according to the above installation specification and eliminate the factors that give electrical load to the both indoor units when installing and operating. (Heater / window / front door / ventilation / partition that divides space)
- You should provide sufficient instructions about the operation method and specification features to users and fill in caution phrases on wired remote controller when necessary.
 - <The air-conditioners in this area are special type to be controlled simultaneously.>

Set up indoor quantity by key switch(K1, K2)

- Press and hold K1 switch to enter the setting mode on the number of the installed indoor unit : Check "A0" sign on 7-segment
 - Press K2 switch to set the number of the installed indoor unit :
 - Ex) If there are two indoor units, press K2 switch twice, and check "A2" sign on 7-segment. If there are three indoor units, press K2 switch three times, and check "A3" sign on 7-segment. If there are four indoor units, press K2 switch four times, and check "A4" sign on 7-segment.
 - Unable to set more than the allowable indoor unit.
 - Ex) In case of the allowable Indoor unit is two : If you press K2 switch repeatedly, 7-segment is changed in order "A0"→"A1"→"A2"→"A0"→"A1".
 - Press K1 switch to complete setting the number of the installed indoor unit : Check "AA" sign on 7-segment.

※ In case you want more information about the controllers and accessories, please refer to the Controller and Accessory TDB on pvi.Samsung.com site or Global Partner Portal site.

2019. 01
Ver.1.0

Samsung Electronics Co., LTD.
B2B PM / SE

Head Office (Suwon Korea) 129, Samsung-Ro, Yeongtong-Gu, Suwon City, Gyeonggi-Do, Korea 16677
Website : www.samsung.com, <http://btsp.samsungsbn.com> Email : airconditioner@samsung.com
Images and data in this book may subject to change without prior notice.